

Parts Catalogue

**MITSUBISHI
DIESEL ENGINE**

6D24-T

for **MG530**

掲 載 内 容

本カタログは、エンジン編です。次の車体カタログと
合わせてご利用ください。

MG530 車体 Pub.No.98160-46920

NOTE

This PARTS CATALOGUE is a Engine Volume.

It is requested that this catalogue be used in
combination with the following catalogue:

MG530 Chassis Parts Catalogue.

Pub.No.98160-46920

January 2009



まえがき

このパーツカタログは、2001年5月以降生産の「6D2型産業用エンジン」に使用されている補用部品を収録してあります。

エンジン型式等の詳細は、後述の「収録エンジン型式一覧表」をご参照下さい。

このパーツカタログを有効に活用いただくには、「イラスト・部品番号リストの見方」を十分にご理解いただくことが重要です。

(部品番号は予告なく変更することがありますので、予めご了承ください。)

(参考)

西暦	2001	2002	2003	2004	2005	2006
元号	平成 13	平成 14	平成 15	平成 16	平成 17	平成 18

年号対照表

西暦	2007	2008	2009
元号	平成 19	平成 20	平成 21

★★

三菱ふそう純正部品のご使用について

三菱ふそうのエンジンには「三菱ふそう純正部品」をご使用ください。

「三菱ふそう純正部品」は弊社の卓越した品質管理のもとで厳格な検査に合格した優秀な部品ですから、安心してご使用していただけるものです。

イミテーション部品は材質、製造方法などすべての点で純正部品と比較にならないので、ご使用にならないでください。「三菱ふそう純正部品」は弊社販売会社に豊富に取りそろえてありますので、「三菱ふそう純正部品」とご指定のうえ、最寄りの販売会社でお買い求めください。

★★

特殊工具は記載されておりません。整備解説書または、特殊工具一覧表を参照して下さい。
(供給は補用部品ルートでいたします。)

FOREWORD

This Parts Catalog contains information on service parts for the 6D2 industrial engines manufactured for customers in general since May 2001.

For the detail of the engine models, refer to the List of Applicable Engine Models herein contained.

In order to use this catalog effectively, it is important to gain a good understanding of "HOW TO USE ILLUSTRATION AND PART NO. LIST".

(The part numbers may be changed without prior notice.)

★★

MITSUBISHI FUSO GENUINE PARTS

Use "MITSUBISHI FUSO GENUINE PARTS" exclusively for servicing your Mitsubishi Fuso engine.

"MITSUBISHI FUSO GENUINE PARTS" are superior and reliable because they have been produced under the excellent quality-control system, and have passed the standard after strict inspections.

Imitation parts are not recommended from the viewpoint of their material and manufacturing method which are entirely incomparable with those of genuine parts.

A large assortment of "MITSUBISHI FUSO GENUINE PARTS" is always available at any of our authorized dealers, so do your purchasing at your nearest dealer by specifying "MITSUBISHI FUSO GENUINE PARTS".

★★

This Parts Catalog does not cover the special tools, for which please refer to the Workshop Manual or the List of Special Tools. (The special tools are available through the service part supply route.)

適用エンジン番号のしらべ方

HOW TO LOCATE APPLICABLE ENGINE NO.

シリンダブロックの下図の位置に打刻してあります。

The engine number is stamped on the cylinder block at the location shown in the following illustration.

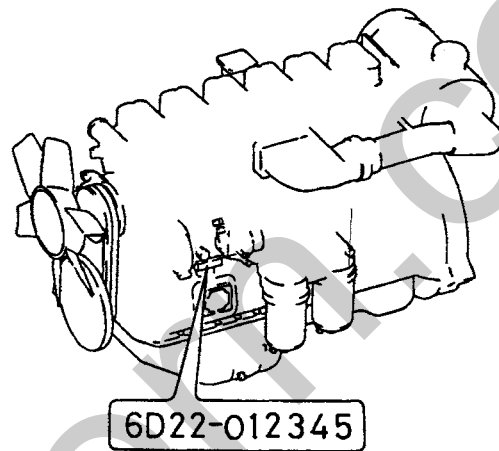

収録エンジン型式一覧表

LIST OF APPLICABLE ENGINE MODELS

エンジン型式名称 Engine model name	エンジン型式記号 Engine model code		適用機種 Applicable machine, vehicle, etc.	適用エンジン番号 Applicable engine No.
	型式	類別		
6D24-T	6D240	CTJS07000	MG530 輸出用 For Export	6D24-313134(01/5)~

Silverhorn.CO.UK

イラスト・部品番号リストの見方

イラスト・部品番号リストは次の通り記載しています。

① ②

11-210 ピストン, コネチング ロッド & クランクシャフト

③ 6D2

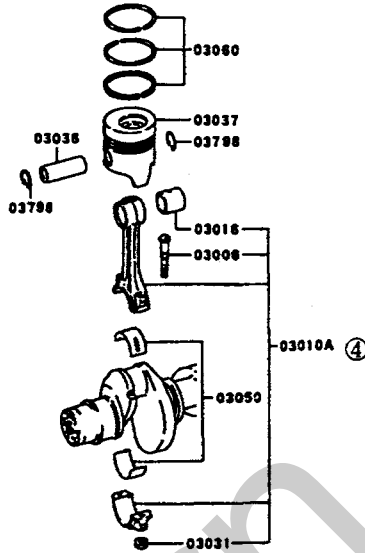

⑭ ZG0020

① ②

11-210 ピストン, コネチング ロッド & クランクシャフト

④ ⑤ ⑥ ⑦ ⑧ ⑨ 02 6D311 CTJS01131 ⑩ ⑪ ⑫ ⑬
01 6D311 CTJS01000

見出番号 REF.-NO.	部品番号 PART NO.	代用 品 R/S /E P/Q	部品名称 および 記事・仕様記号 PART NAME & DESCRIPTION	型式・個数 MODEL & QTY				適用号機 APPLICABLE SERIAL NO.		⑪ R/D	⑫ R/D
				0	1	2		FROM	TO		
03006	MEO12232		BOLT, CONNROD 12X85	12	12			9100-1			
03010A	MEO12265		CONNECTING ROD ASSY	6	6			9100-1			
03016	MEO12234		BUSHING, CONNROD	6	6			9100-1			
03021	MEO23769		CONE, CRANKSHAFT PULLEY	1	1			9100-1			
03022	MEO88101		DAMPER, CRANKSHAFT TORSIONAL	1	1			9100-1			
03031	MEO23570		NUT, CONNROD FLANGE, 12	12	12			9100-1			
03036	MEO12009		PIN, PISTON 34X84	6	6			9100-1			
03037	MEO12858		PISTON STD	6	6			9100-1			
03037	MEO12859		PISTON O/SIZE 0.25	6	6			9100-1			
03037	MEO12860		PISTON O/SIZE 0.50	6	6			9100-1			

① グループ番号

メイン・サブグループのNo.を示します。メイン・サブグループ及びグループ名称を熟知されると部品番号検索がより容易になります。

② サブグループ名称

サブグループの名称を示し、それぞれのグループに収録されている代表部品および装置の名称などを示します。

③ イラスト特徴

それぞれのイラストタイトルとしてふさわしい、エンジン型式、年式などの特徴項目を示します。

④ 見出番号

イラストと部品番号リストを結びつける役目をします。

左側、右側の区分は次のように表示します。

〔例〕 左側＝ 12047L マニホールド, エキゾースト, フロントLH

右側＝ 12047R マニホールド, エキゾースト, フロントRH

⑤ 部品番号

当該エンジンに使用している部品番号を示します。

⑥ 代替部品

部品の変更には、互換性のある変更とない変更とがあります。このうち、新部品が旧部品の代わりに使用できるとき、新部品を旧部品の代替部品といい次のように表示します。

1) 代替欄におけるマークの意味

マーク	意 味
R	新・旧部品のどちらでも使用できる場合
3	新部品は旧部品の代わりに使用でき、旧部品は旧エンジンにのみ使用できる場合
#	新部品を旧部品の代わりに使用するとき、条件付きの代替部品があることを示します。

2) 代替部品番号の見方

見出番号 REF-NO.	部品番号 PART NO.	代 替 R / P	変 更 順 S E Q	記 号 C N G	部品名称および記事・仕様記号 PART NAME & DESCRIPTION	型式・個数 MODEL & QTY				適用号機 APPLICABLE SERIAL NO.	管 区 M / R	新 規 V R D
						0 1	0 2			FROM@-@UPTO		
04903A	MD008784 (MD132260)	3			CAP ASSY, ENG OIL FILLER	1	1			9106・ 1		

() 内の部品番号は代替新部品番号を示します。

⑦ 変更順番号, 変更記号 (今回は省略してあります。)

1) 変更順番号

部品の変更経歴順に1, 2……と付番しています。

2) 変更記号

部品の変更等の内容を記号で表示しています。

⑧ 部品名称

部品名称は補足名称も含めて示します。

⑨ 型式・適用

該当部品が使用される型式を示します。このパーツカタログに収録されているエンジン型式の詳細は“収録エンジン型式一覧表”をご覧ください。

⑩ 個数

エンジン1台分の使用個数を示します。

⑪ 適用号機

当該部品を使用しているエンジンの生産開始・終了時期を示します。

[例] 9010・2 - 9107・1

1990年10月中旬から

↓

1991年7月初旬まで生産

(1 : 初旬 2 : 中旬 3 : 下旬)

⑫ 管理区分 (今回は省略してあります)

この欄に“A”の表示がある部品は、高需要部品の意味を表します。

各代理店殿におかれましては、常時在庫品の目安にしてください。

⑬ 新規部品記号

前回発行後に変更のあった部品、又は新規に発生した部品に対し“V”を表示してあります。

⑭ イラスト管理No.

弊社におけるイラスト管理のためのNo.です。

ご 注 意

パーツカタログ上のイラストは部品の形状、位置を部品注文に支障のない範囲で示してあります。

HOW TO USE ILLUSTRATION AND PART NO. LIST

The illustrations and part No. list are prepared as follows:

- ① ②

11-210 PISTON, CONNECTING ROD & CRANKSHAFT

③ 6D2

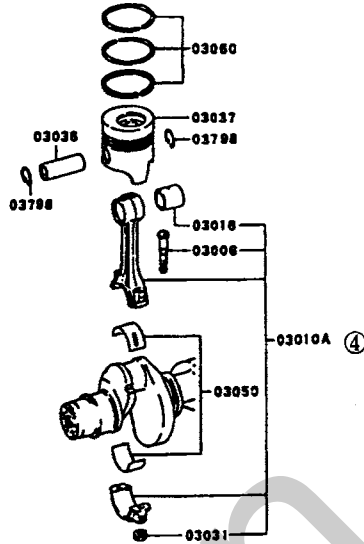

⑭ 2G 0020

- ① ②

11-210 PISTON, CONNECTING ROD & CRANKSHAFT

- ④ ⑤ ⑥ ⑦ ⑧ ⑨ 02 6D311 CTJS01131 ⑩ ⑪ ⑫ ⑬
01 6D311 CTJS01000

見出番号 REF.-NO.	部品番号 PART NO.	部品名称 および 記事・仕様記号 PART NAME & DESCRIPTION	型式・個数 MODEL & QTY				適用号機 APPLICABLE SERIAL NO.	管理 M/V R/D
			0 1	0 2				
03006	ME012232	BOLT, CONNROD 12X85	12	12			9100-1	
03010A	ME012265	CONNECTING ROD ASSY	6	6			9100-1	
03016	ME012234	BUSHING, CONNROD	6	6			9100-1	
03021	ME023769	CONE, CRANKSHAFT PULLEY	1	1			9100-1	
03022	ME088101	DAMPER, CRANKSHAFT TORSIONAL	1	1			9100-1	
03031	ME023570	NUT, CONNROD FLANGE, 12	12	12			9100-1	
03036	ME012009	PIN, PISTON 34X84	6	6			9100-1	
03037	ME012858	PISTON STD	6	6			9100-1	
03037	ME012859	PISTON O/SIZE 0.25	6	6			9100-1	
03037	ME012860	PISTON O/SIZE 0.50	6	6			9100-1	

① Group No.

The Main-Sub Group No. is indicated. An intimate knowledge of the Main-Sub Group and Group Titles will facilitate the retrieval of the part numbers.

② Sub Group Title

Indicates the title of the Sub Group. The titles show the names of the representative parts, equipment or the like contained in the respective groups.

③ Illustration feature

Indicates the engine model, model year, destination code and other appropriate feature items for the respective illustrations.

④ Reference number

Serves to combine the illustration with the part number list.

The LH and RH parts are indicated as follows.

[Example] LH part= 12047L MANIFOLD,EXHAUST,FRONT,LH

RH part= 12047R MANIFOLD,EXHAUST,FRONT,RH

⑤ Part No.

Indicates the part number of the part used for the applicable engine model.

⑥ Replacement part(R/P)

Changes made in a part involve the change which permits interchange of parts and that not permitting interchange of parts. When a new part can be used in place of the old part, the new part is called replacement part of the old part and indicated as follows:

1) Meaning of each mark used in replacement(R/P)column

Mark	Meaning
R	Either new part or old part may be used.
3	New part may be used in place of old part but old part may be used on old engine only.
#	New part may be used in place of old part under a certain condition.

2) Replacement part number

見出番号 REF-NO.	部品番号 PART NO.	代 替 R / P	変 更 順 号 S E Q	記 号 C N G	部品名称および記事・仕様記号 PART NAME & DESCRIPTION	型式・個数 MODEL & QTY				適用号機 APPLICABLE SERIAL NO.		管 区 M / R	新 規 V R D
						0	1	2		FROM@-	-@UPTO		
04903A	MD008784 (MD132260)	3			CAP ASSY, ENG OIL FILLER	1	1			9106	1		

The part No. shown in () is a replacement part number.

⑦ Sequence-of-change numbers & Change codes (Omitted)

1) Sequence-of-changed numbers

The parts are changed for improved quality or performance. Their changes are indicated in sequence by numerals (1.2.3...).

2) Change codes

These codes indicate the reason or purpose of changes of the parts.

⑧ Part name

The part name is indicated together with the complementary name.

⑨ Model type /Description

The applicable models of respective parts are indicated in this column.

For the detail of the engine models put in this Parts Catalog, refer to the "LIST OF APPLICABLE ENGINE MODELS".

⑩ Quantity

Indicates the number of parts used per engine.

⑪ Applicable serial numbers

Indicates the date of beginning the production of the engine incorporating the applicable part and that of ending its production.

[Example] 9010·2 - 9107·1

Built from the middle of October 1990 up to early in July 1991

(1:early, 2:middle 3:late)

⑫ Management rank (Omitted)

Parts ranked as "A" are high-demand parts. This ranking is to be referred to by dealers, and is devised to facilitate and rationalize their distribution, stocking and inventory of the parts.

⑬ Parts changed or added after the last parts catalogue that has been published are identified by "V".

⑭ Illustration control No.

This number is used for illustration control by Mitsubishi.

NOTE

The illustrations in this Parts Catalog show the part shape and location only to be adequate for ordering of the part.

エンジン番号一覧表
LIST OF ENGINE NUMBERS

YEAR	ENG	1月	2月	3月	4月	5月	6月	7月	8月	9月	10月	11月	12月
	MODEL	Jan	Feb	Mar	Apr	May	Jun	Jul	Aug	Sep	Oct	Nov	Dec
2001	6D240	309123	309976	310744	311644	312456	313235	313898	314870	315592	316405	317144	317993

YEAR	ENG	1月	2月	3月	4月	5月	6月	7月	8月	9月	10月	11月	12月
	MODEL	Jan	Feb	Mar	Apr	May	Jun	Jul	Aug	Sep	Oct	Nov	Dec
2002	6D240	318897	319627	320476	321230	321872	322469	323361	324469	325604	326650	327558	328614

YEAR	ENG	1月	2月	3月	4月	5月	6月	7月	8月	9月	10月	11月	12月
	MODEL	Jan	Feb	Mar	Apr	May	Jun	Jul	Aug	Sep	Oct	Nov	Dec
2003	6D240	329628	330810	331964	332916	334204	335198	336525	338415	339655	341183	342622	344255

YEAR	ENG	1月	2月	3月	4月	5月	6月	7月	8月	9月	10月	11月	12月
	MODEL	Jan	Feb	Mar	Apr	May	Jun	Jul	Aug	Sep	Oct	Nov	Dec
2004	6D240	345935	346889	348249	349251	350223	351346	352664	354106	355233	356600	357811	358808

YEAR	ENG	1月	2月	3月	4月	5月	6月	7月	8月	9月	10月	11月	12月
	MODEL	Jan	Feb	Mar	Apr	May	Jun	Jul	Aug	Sep	Oct	Nov	Dec
2005	6D240	359817	360806	362136	363795	364877	366143	367691	368896	369916	371909	373640	375331

YEAR	ENG	1月	2月	3月	4月	5月	6月	7月	8月	9月	10月	11月	12月
	MODEL	Jan	Feb	Mar	Apr	May	Jun	Jul	Aug	Sep	Oct	Nov	Dec
2006	6D240	377013	378545	380005	381750	383130	384078	386222	388323	389944	391797	393176	394787

YEAR	ENG	1月	2月	3月	4月	5月	6月	7月	8月	9月	10月	11月	12月
	MODEL	Jan	Feb	Mar	Apr	May	Jun	Jul	Aug	Sep	Oct	Nov	Dec
2007	6D240	396093	397120	398584	400193	401658	403142	404720	406476	407981	409520	411152	412620

YEAR	ENG	1月	2月	3月	4月	5月	6月	7月	8月	9月	10月	11月	12月
	MODEL	Jan	Feb	Mar	Apr	May	Jun	Jul	Aug	Sep	Oct	Nov	Dec
2008	6D240	414046	415404	416900	418473	419845	421066	422688	424516	425777	427605	429277	430369

YEAR	ENG	1月	2月	3月	4月	5月	6月	7月	8月	9月	10月	11月	12月
	MODEL	Jan	Feb	Mar	Apr	May	Jun	Jul	Aug	Sep	Oct	Nov	Dec
2009	6D240												

記号・略語一覧表
ABBREVIATIONS AND SYMBOLS

(G)	: Graphite (グラファイト)	スプラッシュ	: Splash Shield (スプラッシュ シールド)
(M)	: Metallic (メタリック)	スライド	: Sliding (スライディング)
(P+G)	: Pearl Graphite (パール グラファイト)	ターボ	: T/C(Turbocharger) Turbocharger (ターボチャージャー)
(P)	: Pearl (パール)	チャージ	: Charging (チャージング)
&	: And (アンド)	デカル	: Decalcomania (デカルコマニヤ)
*	: 非部供	デコンプ	: Decompression (デコンプレッション)
**	: 部番設定中	デフ	: Differential (デファイナシャル)
*GS	: 日本電池(株)	トルコン	: Torque Converter (トルク コンバータ)
*MEC	: 三菱電機(株)	ナックル	: Steering Knuckle (ステアリング ナックル)
*MHI	: 三菱重工業株式会社(販社直購品)	ハイドロ	: Hydraulic (ハイドロリック)
*ND	: 株式会社デンソー(販社直購品)	ハランサ	: Counterbalancer (カウンタ ハランサ)
*YOKOHAMA	: 横浜ゴム(株)	パーク	: Parking (パーキング)
"	: Inch (インチ)	パワステ	: Power Steering (パワー ステアリング)
アキュム	: Accumulator (アキュムレータ)	ブッシュ	: Bushing (ブッシング)
アクセル	: Accel(Accelerator) Accelerator (アクセルレータ)	ブレーカ	: Contact Breaker (コンタクト ブレーカ)
アクチュエート	: Actuating (アクチュエーティング)	プロポバルブ	: Proportioning Valve (プロポーションングバルブ)
アジャスト	: Adjusting (アジャスティング)	ペラシャフト	: Propeller Shaft (プロペラ シャフト)
アタッチ	: Attachment (アタッチメント)	ボタン	: Push Button (プッシュ ボタン)
アンプ	: Amplifier (アンプリファイヤ)	マイク	: Microphone (マイクホン)
インタメシャフト	: Intermediate Shaft (インタメディエイト シャフト)	マウント	: Mounting (マウンティング)
インパネ	: Instrument Panel (インストルメント パネル)	マルチ	: Multiple (マルチプル)
ウインド	: Windshield (ウインドシールド)	モール	: Moulding (モールディング)
ウエザ	: W/Strip(Weatherstrip) Weatherstrip (ウエザストリップ)	リーンホース	: Reinforcement (リーンホースメント)
エアアウト	: Air Outlet (エア アウトレット)	リクライ	: Reclining (リクライニング)
エアイン	: Air Inlet (エア インレット)	リサーキュレート	: Recirculation (リサーキュレーション)
エアコン	: Air Conditioner (エア コンディショナ)	リモコン	: Remote Control (リモート コントロール)
エアサス	: Air Suspension (エア サスペンション)	ルブリケート	: Lubricating (ルブリケーティング)
イクイブ	: Equip(Equipment) Equipment (イクイブメント)	レギュレート	: Regulating (レギュレーティング)
オート	: Auto(Automatic) Automatic (オートマチック)	レデュース	: Reducing (レデュースィング)
オペレート	: Operatong (オペレーティング)	ロック	: Locking (ロッキング)
カウルベント	: Cowl Ventilator (カウル ベンチレータ)	ロッド	: Push Rod (プッシュ ロッド)
キャタコン	: Catalytic Converter (キャタリチック コンバータ)	A	: Ampere (アンペア)
コネク	: Connecting (コネクティング)	A/C	: Air Conditioner (エア コンディショナ)
コンパート	: Compartment (コンパートメント)	A/CLNR	: Air Cleaner (エア クリーナ)
コンビ	: Combination (コンビネーション)	A/F	: Air Fuel (エア フェュエル) Air Fuel Ratio (エア フェュエル レシオ)
コンプレッサ	: Air Compressor (エア コンプレッサ)	A/G	: Auto Greaster (オート グリスタ)
コンペンセート	: Compensating (コンペンセーティング)	A/H	: Air Over Hydraulic Brake (エア オーバ ハイドロリック ブレーキ)
コンロッド	: Connecting Rod (コネクティング ロッド)	A/SUSP	: Air Suspension (エア サスペンション)
サス	: Susp(Suspension) Suspension (サスペンション)	A/T	: Auto Transaxle (オート トランスアクスル) Auto Transmission (オート トランスミッション)
ショック	: Shock Absorber (ショックアブソーバ)	ABS	: Anti-Lock Brake Control System (アンチロック ブレーキ コントロール システム)
シンクロ	: Synch(Synchronizer) Synchronizer (シンクロナイザ)	ABSジュシ	: アクリロニトル・ブタシエン・スチレン・ジュシ
		AC	: Alternating Current (交流)

ACCEL	: Accelerator (アクセルレータ)	BRZ	: Bronze (ブロンズ)
ACV	: Air Cut Valve (エア カット バルブ)	BSTR	: Booster (ブースタ)
AGPM	: Auto Glare Proof Mirror (自動防眩ミラー)	B020	: (株)ハンザイ
AGS	: Auto Guide System (オートガイドシステム)	C-	: Clear (クリア)
AL	: Aluminum (アルミニウム)	C-LP	: Courtesy Lamp (コーティンイ ランプ)
AL/WHL	: Alminum Wheel (アルミ ホイール)	C/Lルーフ	: クリスタルライトルーフ
ALR	: Auto Lock Retractor (オートロックリトラクタ)	C/UP	: Capacity Up (容量アップ)
ALTNTR	: Alternator (オルタネータ)	C/ZONE	: Cold Zone (寒冷地)
AM	: Amplitude Modulation (アンプリチュード モジュレーション)	CA/CONV	: Catalytic Converter (触媒)
ANTI-CORR	: Anti-Corrosion (アンチ コロージョン)	CA/T	: Column Shift A/T (コラムシフト A/T)
ANTI-POLL	: Anti-Pollution (アンチ ポリューション)	CARB	: Carburetor (キャブレタ)
AR	: As Required (所要量)	CAS/PLAY	: Cassette Player (カセット プレーヤ)
ARG	: Argent (アージェント)	CC	: Choice (選択)
ASC	: Active Stability Control (アクティブ スタビリティコントロール)	CD	: Compact Disc (コンパクト ディスク)
	: Auto Speed Control (オートスピードコントロール)	CHARG	: Charger (チャージャ)
ASG	: Automatic Stop & Go (オートマチック ストップ & ゴー)	CHK	: Check (チェック)
ASR	: Anti-Spin Regulator (アンチスピンレギュレータ)	CHR	: Charger (チャージャ) : Chrome (クロム)
ASSY	: Assembly (アセンブリ)	CKT	: Circuit (回路)
AUTO	: Automatic (オートマチック)	CL	: Clutch (クラッチ)
AUX	: Auxiliary (オグジリアリ)	CL-	: Cool (クール)
AYC	: Active Yaw Control (アクティブヨーコントロール)	CLO	: Cloth (クロス)
A001	: (株)ADオーパースーズ	CLO/ST	: Cloth Seat (クロスシート)
A082	: 曙ブレーキ工業株式会社	CLR	: Cooler (クーラ)
A123	: (株)アドヴァンクス	CLRLS	: Inter Cooler Less (インタクーラレス)
A126	: 安全自動車(株)	CM/T	: Column Shift M/T (コラムシフト M/T)
A139	: 青木科学研究所	CNG	: Compressed Natural Gas (圧縮天然ガス)
A216	: 旭硝子株式会社	COL	: Colored (カラート)
B-	: Bright (ブライト)	COMPR	: Compressor (コンプレッサ)
BATT	: Battery (バッテリー)	CONNROD	: Connecting Rod (コネクティング ロッド)
BGE	: Beige (ベージュ)	CONST	: Construction (コンストラクション)
BJ	: Birfield Joint (バーフィールドジョイント)	CONT	: Control (コントロール)
BLA	: Black (ブラック)	CR-	: Creamy (クリーミ)
BLU	: Blue (ブルー)	CRU/CONT	: Cruise Control (クルーズコントロール)
BMPR	: Bumper (バンパ)	CTR	: Center (センタ)
BOSCH	: ボッシュ株式会社	CYL	: Cylinder (シリンダ)
BPV	: Blend Proportioning Valve (ブレンド プロポーションング バルブ)	CZ	: Cold Zone (寒冷地)
BRG	: Bearing (ベアリング)	C010	: クラリオン(株)
BRK	: Brake (ブレーキ)	C012	: セントラル産業(株)
BRKT	: Bracket (ブラケット)	D	: Diameter (直径)
BRN	: Brown (ブラウン)	D.S.C	: Disc Specification (ディスク スペック)
BRT	: Bright (ブライト)	D-	: Dark (ダーク)
		D/ミラー	: Door Mirror (ドアミラー)
		D/リモコン	: Direct Remote Control (ダイレクトリモートコントロール)
		D/MR	: Door Mirror (ドアミラー)
		D/PR	: Dust Proof (ダストプルーフ)
		D/PROOF	: Dust Proof (ダストプルーフ)

D/T	: ディーゼルターボ	EGR	: Exhaust Gas Recirculation (排ガス再循環装置)
DBL	: Double (ダブル)	ELC-A/T	: Electronic Control Auto Transmission (エレクトロニックコントロール オートトランスミッション)
DC	: Direct Current (直流)	ELCAT	: Electronic Control Auto Transmission (エレクトロニックコントロール オートトランスミッション)
DD	: Direct Drive (ダイレクトドライブ)	ELEC	: Electric (エレクトリック)
DECAL	: Decalcomania (デカルコマニヤ)	ELEC/CONT	: Electric Control (エレクトリックコントロール)
DEFOG	: Defogger (デフォグガ)	ELR	: Emergency Lock Retractor (エマージェンシ ロックリトラクタ)
DI-D	: Direct Injection Diesel (ダイレクトインジェクションディーゼル)	EMERG	: Emergency (緊急)
DIE	: Diesel (ディーゼル)	ENG	: Engine (エンジン)
DIFF	: Differential (テアレンシャル)	EPS	: Electronic Control Power Steering (エレクトロニックコントロール パワー ステアリング)
DIR	: Direct (ダイレクト)	EQL	: Equalizer (イコライザ)
DIR/CONT	: Direct Control (ダイレクトコントロール)	EQUIP	: Equipment (イクイップメント)
DOHC	: Double Overhead Camshaft (ダブルオーバヘッドカムシャフト)	ESS	: Engine Speed Sensor (エンジンスピードセンサ)
DOJ	: Double Offset Joint (ダブルオフセットジョイント)	ESV	: Enrichment Solenoid Valve (エンリッチメントソレノイドバルブ)
DOM	: Domestic (ドメスティック)	ETACS	: Electronic Time & Alarm Control System (エレクトロニックタイム & アラーム コントロールシステム)
DP-	: Deep (ディープ/濃い)	ETC	: Electronic Toll Collection System (エレクトロニックトールコレクションシステム)
DPF	: Diesel Particulate Filter (ディーゼルパーティキュレートフィルタ)	ETR	: Electronic Tuner (エレクトロニックチューナ)
DQ	: ダイヤクイン	EV	: Electrical Vehicle (電気自動車)
DR	: Door (ドア)	EVA	: エチレン酢ビ樹脂
DRL	: Day Time Running Light (データイムランニングライト)	EXC	: Except (除く)
DSV	: Deceleration Solenoid Valve (デセレーションソレノイドバルブ)	EXH	: Exhaust (エキゾースト)
DUL-	: Dull (ダル/くすんだ)	EXP	: Export (エクスポート)
DVD	: Digital Versatile Disc (デジタル多用途ディスク)	EXT	: Exterior (エクステリア/外装コード)
D001	: ダイヤケミカル(株)	EZGO	: Easy Go (坂道発進補助装置 & パーキングサポートシステム / イージーゴー)
D234	: 株式会社デンソー	F-N-R	: Forward, Neutral & Reverse (フォワード, ニュートラル & リバース)
E/M	: Electromagnetic (電磁式)	F/ミラー	: Fender Mirror (フェンダミラー)
EBS	: Electronic Control Brake System (電子制御ブレーキシステム)	F/A	: Full Air Brake (フルエアブレーキ)
EC	: Electric Control (エレクトリックコントロール)	F/DISC	: Front Disc (フロントディスク)
ECI	: Electronic Control Injection (エレクトロニックコントロールインジェクション)	F/MR	: Fender Mirror (フェンダミラー)
ECM	: Electronic Control Engine Mounting (エレクトロニックコントロールエンジンマウンティング)	F/PWR	: Full Power (フルパワー)
ECS	: Electronic Control Suspension (エレクトロニックコントロールサスペンション)	F/TANK	: Fuel Tank (燃料タンク)
ECSA	: Electronic Control Shock Absorber (エレクトロニックコントロールショックアブソーバ)	F/TRAILER	: Full Trailer (フルトレーラ)
ECU	: Electronic Control Unit (エレクトロニックコントロールユニット)	F/W	: Flywheel (フライホイール)
ECW	: Electro Chromic Window (エレクトロクロミックウインドウ)	Fクランプ	: フットクランプ
ED	: Economy Drive (エコミドライブ)	FA/T	: Floor Shift A/T (フロアシフトA/T)
		FL/CPLG	: Fluid Coupling (フルイドカップリング)

FLAME/ RESIST	: Flammability Resistance (難燃仕様)	HI	: High (ハイ)
FLTG	: Floating (フロティング)	HID	: High Intensity Discharge (高輝度放電式電球)
FLUOR	: Fluorescent (蛍光灯)	HL/WSHR	: Headlamp Washer (ヘッドランプワッシャー)
FM	: Frequency Modulation (フリークエンス モデュレーション)	HLG	: Halogen (ハロゲン)
FM/T	: Floor Shift M/T (フロア シフト M/T)	HMSL	: High Mount Stop Lamp (ハイ マウント ストップ ランプ)
FR	: Front (フロント)	HTL	: Heater Less (ヒータ レス)
FRP	: ガラス繊維強化プラスチック	HTR	: Heater (ヒータ)
FUP	: Front Underrun Protector (フロント アンダラン プロテクタ)	HZ	: Hot Zone (酷暑地)
FWD	: Forward (フォワード)	H022	: ハマニ化成(株)
G-	: Grayish (グレイッシュ)	H086	: (株)初田製作所
G/RATIO	: Gear Ratio (ギヤ比)	H158	: 日野屋貿易(株)
G/ZONE	: General Zone (一般地域)	I/CLR	: Inter Cooler (インタクーラ)
GER	: Germany (ジャーマニー)	I/PANEL	: Instrument Panel (インストルメント パネル)
GLA	: Glass (ガラス)	I/PNL	: Instrument Panel (インストルメント パネル)
GLD	: Gold (ゴールド)	IC	: Integrated Circuit (インテグレートッド サーキット)
GLPG	: Glow Plug (グロー プラグ)	INCR/TANK	: Increased Tank (増量タンク)
GOV	: Governor (ガバナ)	IND	: Indicator (インジケータ)
GRG	: Grayge (グレイージュ)	INDEP	: Independent (独立)
GRL	: Grille (グリル)	INJ	: Injection (噴射)
GRN	: Green (グリーン)	INOMAT	: Intelligent & Innovative Mechanical Automatic Transmission (機械式自動トランスミッション /イノマト)
GRY	: Gray (グレイ)	INR	: Inner (インナ)
GS	: 日本電池(株)	INT	: Interior (インテリア, 内装コート)
GT	: Ground Touring (グラント ツーリング)	IS	: Idling Stop System (アイドリング ストップ システム)
GZ	: General Zone (一般地域)	ISS	: Idling Stop & Start System (アイドリング ストップ & スタート システム)
H.A.W.	: Highray Absorptive Window Glass (高熱線吸収ガラス)	IVO	: Ivory (アイボリー)
H-L	: High & Low (ハイ & ロー)	I010	: 出光興産(株)
H/ミラー	: Hood Mirror (フード ミラー)	JMSV	: Jet Mixture Solenoid Valve (ジェット ミックスチャ ソレノイドバルブ)
H/BACK	: Hatch Back (ハッチ バック)	J015	: ジェコ(株)
H/DUTY	: Heavy Duty (ヘビー デューティ)	KOS	: Keyless Operation System (キーレス オペレーション システム)
H/GRADE	: High Grade (ハイ グレード)	KPH	: Kilometer Per Hour (キロメートル/時間)
H/GROUND	: High Ground (ハイ グラウンド)	KW	: Kilo Watt (キロワット)
H/LP	: Headlamp (ヘッドランプ)	K068	: コスベル化工(株)(兼松江商)
H/MR	: Hood Mirror (フード ミラー)	K480	: 株式会社 小糸製作所
H/REST	: Headrest (ヘッドレスト)	K481	: (株)小糸製作所
H/ROOF	: High Roof (ハイ ルーフ)	K558	: (株)コシダテック
H/S	: High Speed (ハイ スピード)	K698	: クシロブレキ株式会社
H/ZONE	: Hot Zone (酷暑地)	K699	: クノールブレムゼ商用車システムジャパン(株)
HA	: High Altitude (高地)	K838	: 協和商工(株)
HAC	: High Altitude Compensator (高地補正装置)	L	: Length (長さ)
HARN	: Harness (ハーネス)		
HCO	: Height Control (ハイト コントロール)		
HEV	: Hybrid Electric Vehicle (ハイブリッド エレクトリック ビークル)		

L-	: Light (ライト)	MDAS	: Mitsubishi Driver's Attention Monitoring System (運転注意力モニタ/エムダス)
L-R	: Low & Reverse (ロー & リバース)	MDS	: Multi Display Station (マルチディスプレイステーション)
L/B	: Lock Brake (ロックブレーキ)	MEC	: 三菱電機(株)
LAV	: Lavender (ラベンダ)	MECH	: Mechanical (メカニカル)
LB	: Pound (ポンド)	MHI	: 三菱重工業株式会社
LCD	: Liquid Crystal Display (液晶)	MICS	: Mitsubishi Intelligent Cockpit System (三菱インテリジェントコックピットシステム)
LDG	: Loading (積載量)	MID	: Middle (ミドル)
LEA	: Leather (レザー)	MILS	: Mitsubishi Intelligent Load Monitoring System (積載モニター/ミルス)
LEA/ST	: Leather Seat (レザーシート)	MIN	: Minimum (ミニマム)
LED	: Light Emitting Diode (ライトエミティングダイオード)	MIQCS	: Mitsubishi Innovative Quiescent Combustion System (クワイエッセント燃焼/ミックス)
LH	: Left Hand (左側)	MIR	: Mirror (ミラー)
LHD	: Left Hand Drive (レフトハンドドライブ)	MLDG	: Moulding (モールディング)
LP	: Lamp (ランプ)	MMAT	: Mitsubishi Mechanical Automatic Transmission (三菱メカニカルオートマチックトランスミッション)
LPG	: Liquefied Petroleum Gas (液化石油ガス)	MPH	: Mile Per Hour (マイル/時間)
LRG	: Large (ラージ)	MPI	: Multi Point Injection (マルチポイントインジェクション)
LSD	: Limited Slip Differential (リミテッドスリップデファレンシャル)	MPX	: Multiplex (マルチプレックス)
LSP	: Load Sensing Proportioning (ロードセンシングプロポーションング)	MRN	: Maroon (マルーン)
LSPV	: Load Sensing Proportioning Valve (ロードセンシングプロポーションングバルブ)	MSD	: Mitsubishi Super Drive (三菱スーパードライブ/軸重移動装置)
LSV	: Load Sensing Valve (ロードセンシングバルブ)	MTR	: Meter (メータ)
LW	: Long Wave (長波)	MUT	: Multi-Use Tester (マルチユーステスタ)
LWR	: Lower (ロー)	MW	: Middle Wave (中波)
M	: Model Year (年式)	M018	: (株)万喜商会
M-	: Medium (ミディアム)	M039	: 丸愛産業(株)
M/CYL	: Master Cylinder (マスターシリンダ)	M150	: 松下電気産業(株)
M/T	: Manual Transaxle (マニュアルトランスアクスル) Manual Transmission (マニュアルトランスミッション)	M236	: ミドリ安全(株)
M/TOP	: Metal Top (メタルトップ)	M264	: (株) ミニ
MAG	: Magnet (マグネット)	M304	: 水戸工業(株)
MALAY	: Malaysia (マレーシア)	M321	: 三菱電機株式会社
MANF	: Manifold (マニホールド)	M360	: 三菱製鋼株式会社
MATL	: Material (マテリアル)	M400	: 三菱商事(株)
MAX	: Maximum (マキシマム)	M754	: (株) モリタ
MBECS	: Motorvehicle Brake Energy Conservation System (制動エネルギー回生システム/エムベックス)	M814	: 睦商事(株)
MCV	: Mixture Control Valve (ミックスチャャコントロールバルブ)	N-	: Natural (ナチュラル)
MD	: Modulated Displacement (モデュレートッドディスプレイスメント) : Mini Disc (ミニディスク)	NA	: Not Applicable (非適用)
		NAS	: North American Spec (ノースアメリカンスペック)
		ND	: 株式会社デンソー

NGK	: 日本碍子(株)	PAF	: Pulse Air Feeder (パルスエアフィーダ)
NIKK	: 日本インジクタ株式会社	PAL-	: Pale(ペイル/薄い)
NO.	: Number (番号)	PAR	: Parch (パーチ)
NR	: Noise Reducer (エンジン最高回転数制御装置)	PC	: Piece (ピース)
NS	: Not Service (非供給)	PCD	: Pitch Circle Diameter (ピッチサークルダイヤメータ)
N243	: ニュレイトン(株)	PCV	: Positive Crankcase Ventilation (ポジティブクランクケースベンチレーション)
N259	: (株)ナブコ	PDC	: Pneumatic Damping Control Shock Absorber (空気圧式可変ショックアブソーバ)
N268	: 日本パース(株)	PHV	: Pressure Hold Valve (プレッシャホルルトバルブ)
N274	: 日本グリース(株)	PLR	: Pillar (ピラー)
N282	: 日本カーリット(株)	PM	: Particulate Matters (粒子状物質)
N318	: 日本ドナルドソン株式会社	PNC	: Part Name Code (品名コード)
N324	: 日本ドライケミカル(株)	PNK	: Pink (ピンク)
N361	: 日本ヘルメテックス(株)	PNL	: Panel (パネル)
N386	: 日本金属精工(株)	PP/AR	: ホリプロピレン/エラストラマ
N416	: 日本ロックタイト(株)	PP/PEコンボウ	: ホリプロピレン/ポリエチレンコンボウ
N437	: 日本パワーステアリング株式会社	PRESS	: Pressure (プレッシャ)
N438	: 日本パークライジング(株)	PRL	: Pearl (パール)
N464	: 日本濾過器株式会社	PROT	: Protect (プロテクト) Protector (プロテクタ)
N530	: 日本特殊陶業株式会社	PSD	: Power Slide Door (パワースライドドア)
N634	: (株)日豊商事	PSS	: Parking Support System (パーキングサポートシステム)
N687	: 日清紡フレーキ販売株式会社	PT	: Point (ポイント)
N812	: (株)リタケ	PTO	: Power Take Off (パワーテークオフ)
O-	: Off (オフ)	PUR-	: Purple(パープル/紫色)
O/D	: Overdrive (オーバードライブ)	PWM	: Pulse Width Modulation (パルスワイドモジュレーション)
O/S	: Outside (アウトサイド)	PWR	: Power (パワー)
OD	: Outside Diameter (外径) Overdrive (オーバードライブ)	P016	: ハイオニア(株)
OFS	: Offset (オフセット)	P022	: (株)パシフィックモーターケミカルズ
OHC	: Overhead Camshaft (オーバヘッドカムシャフト)	Q/GLOW	: Quick Glow (クイックグロー)
OHV	: Overhead Valve (オーバヘッドバルブ)	Q/WDO	: Quarter Window (クォーターウィンドウ)
OLI	: Olive (オリーブ)	QTR	: Quarter (クォータ)
OP	: Option Code (オプションコード)	QTY	: Quantity (個数)
OPN	: Open (オープン) Opener (オープナー)	R/CONT	: Remote Control (リモートコントロール)
ORG	: Orange (オレンジ)	R/DRUM	: Rear Drum (リヤドラム)
OS	: Oversize (オーバサイズ)	RAD	: Radiator (ラジエータ)
OTR	: Outer (アウト)	RDC	: Reducing (レジューシング)
OWC	: One Way Clutch (ワンウェイクラッチ)	RDO	: Radio (ラジオ)
O252	: (株)大沢ローヤル	RE	: Red (レッド)
P/M	: Permanent Magnet (永久磁石)	RED	: Reduction (リダクション)
P/NO	: Part Number (部品番号)	REFRD	: Refrigerated (冷凍)
P/S	: Power Steering (パワーステアリング)	REINF	: Reinforcement (リーンフォースメント)
P/SEAT	: Passenger Seat (パセンジャシート) Power Seat (パワーシート)		
P/TD	: Powertard (パワータード)		
P/W	: Power Window (パワーウィンドウ)		

REL	: Release (リリース)	SPKR	: Speaker (スピーカ)
REP	: Replacement Code (代替性コード)	SPR	: Spring (スプリング)
REV	: Reverse (リバース)	SPT	: Sputtering (スパッタリング)
REV-TACH	: Revolution Tachograph (レボタコ)	SRS	: Supplemental Restraint System (サブリメンタル レストレイント システム)
RF	: Ratio Of Final (ファイナル レシオ) : Roof (ルーフ)	SSPS	: Speed Sensing Power Steering (車速感応パワーステアリング装置)
RH	: Right Hand (右側)	SS4	: Super Select 4WD (スーパー セレクト 4WD)
RHD	: Right Hand Drive (ライト ハンド ドライブ)	ST	: Seat (シート)
RJ	: Rzeppa Universal Joint (ゼツパ ユニバーサル ジョイント)	STAB	: Stabilizer (スタビライザ)
RP	: 理研ピストン(株)	STD	: Standard (スタンダード)
RPM	: Revolutions Per Minute (回転数/分)	STL	: Steel (スチール)
RPS	: Revolutions Per Second (回転数/秒)	STRG	: Steering (ステアリング)
RR	: Rear (リヤ)	SUS	: Suspension (サスペンション)
RSB	: Raspberry (ラズベリー)	SUSP	: Suspension (サスペンション)
RTD	: Retarder (リターダ)	SW	: Short Wave (短波) : Switch (スイッチ)
RUP	: Rear Underrun Protector (リヤ アンダーラン プロテクタ)	SYNCH	: Synchronizer (シンクロナイザ)
RWD	: Rearward (リヤワート)	SYS	: System (システム)
R058	: (株) リンレイ	S066	: (株) サミット
R155	: (株) 菱和	S068	: (株) サン自動車工業
R190	: 菱自用品販売(株)	S081	: サンエス化学工業(株)
S-	: Soft (ソフト)	S145	: 三興油脂(株)
S-CAB	: Single Cab (シングル キャブ)	S216	: (株) サンダイヤ
S/ABS	: Shock Absorber (ショック アブソーバ)	S247	: 三輪精機株式会社
S/BELT	: Seat Belt (シート ベルト)	S351	: シールイント(株)
S/C	: Super Charger (スーパー チャージャ)	S504	: サンヨー商事(株)
S/METER	: Speedometer (スピードメータ)	S602	: 三菱自動車テクノサービス(株)
S/R	: Sunroof (サンルーフ)	S613	: (株) シンワ
S/STRUCT	: Side Structure (サイド ストラクチャ)	S616	: 新正工業(株)
S/TRAILER	: Semi Trailer (セミ トレーラ)	S639	: シロヤ被服工業(株)
S/WDO	: Side Window (サイド ウィンドウ)	S641	: 静岡化成(株)
S/WHL	: Steering Wheel (ステアリング ホイール)	S664	: スタンレー電気株式会社
SC	: Stability Control (スタビリティ コントロール)	S811	: 昭和飛行機工業(株)
SCE	: Source (ソース)	S815	: 正和工業(株)
SD	: Sand (サンド)	S822	: 昭和シェル石油(株)
SE-	: Semi (セミ)	T	: Thickness (厚さ)
SERV	: Service (サービス)	T/A	: Transaxle (トランスアクスル)
SIK	: Service In Kit (キット供給)	T/C	: Turbocharger (ターボチャージャ)
SIL	: Silver (シルバ)	T/F	: Transfer (トランスファ)
SIR	: Service In Roll (長尺供給)	T/GATE	: Tailgate (テールゲート)
SLD	: Speed Limiter Device (スピード制限装置)	T/M	: Transmission (トランスミッション)
SOHC	: Single Overhead Camshaft (シングル オーバーヘッド カムシャフト)	TA	: TAN (タン)
SP	: Spoke (スポーク)	TACHO	: Tachometer (タコメータ)
SPEC	: Specification (仕様)	TCL	: Traction Control System (駆動力制御機構)
SPI	: Single Point Injection (シングル ポイント インジェクション)	TEL	: Telephone (電話)
		TEMP	: Temperature (温度)

TI	: Titanium (チタン)	VIC	: Variable Induction Control (バリエーブル インダクション コントロール)
TICS	: Timing & Injection Rate Control System (プレストローク電子制御燃料噴射ポンプ)	VIN	: Vehicle Identification Number (ビークル アイデンティフィケーション ナンバ)
TJ	: Tripord Universal Joint (トリポード ユニバーサル ジョイント)	VIO	: Violet (バイオレット)
TOR-CON	: Torque Converter (トルクコンバータ)	VNL	: Vinyl (ビニール)
TORO	: 東京濾過器株式会社	VNL/ST	: Vinyl Seat (ビニールシート)
TP	: 帝国ヒストン(株)	VOIS	: Visual&Oral Information System (多重表示&音声警報システム/ボイス)
TPMS	: Tire Pressure Monitoring System (タイヤ プレッシュ モニタリング システム)	VOL	: Volume (ボリューム)
TPR	: 変性ポリプロピレン	VSS	: Vehicle Speed Sensor (ビークル スピード センサ)
TRQ	: Turquoise (ターコイズ)	VTR	: Video Tape Recorder (ビデオ テープ レコーダ)
TURBO	: Turbocharger (ターボチャージャー)	VV-	: Vivid(ビビッド/鮮やか)
TV	: Television (テレビジョン)	W	: Watt (ワット)
T016	: 大平潤販(株)	W-	: Warm (ウォーム)
T159	: 効力産業(株)	W-CAB	: Double Cab(ダブルキャブ)
T165	: 東海マテリアル株式会社	W/	: With (～付き)
T356	: (株)スリーホン	W/CLR	: With Inter Cooler (インタクーラ 付き)
T378	: 千代田工販(株)	W/INJ	: Wax Injection (ワックス インジェクション)
T392	: (株)トーケン	W/O	: Without (～無し)
T540	: ティービーケー販売(株)	W/P	: Wheel Parking Brake (ホイールパーキング ブレーキ)
T595	: 東京濾過器株式会社	W/SHLD	: Windshield (ウインドーシールド)
T698	: トビー実業(株)	W/STRIP	: Weatherstrip (ウエザーストリップ)
T716	: トーシンテック(株)	WB	: Wheel Base (ホイールベース)
T725	: 栃木富士産業(株)	WD	: Wood (ウッド)
T752	: (株)東洋アイテック	WDO	: Window (ウインドウ)
T826	: 東洋製鎖工業(株)	WHT	: White (ホワイト)
T955	: (株)中外	WO	: Without (～無し)
T984	: 中央交易(株)	WO/WPR	: Without Wiper (ワイパ無し)
U/D	: Under Drive(アンダドライブ)	WSHR	: Washer (ワッシャ)
UCC	: Under-Floor Catalytic Converter (アンダフロア キャタリティック コンバータ)	WT/WPR	: With Wiper (ワイパ付き)
UPR	: Upper (アッパー)	W016	: 和興産業株式会社
US	: Undersize (アンダサイズ)	YEL	: Yellow (イエロ)
U023	: (株)U.S.C	YOKOHAMA	: 横浜ゴム(株)
U027	: (株)ユニワールド産業	Y094	: (株)山三商事
V	: Volt (ボルト)	Y205	: 矢崎総業(株)
V/G	: Variable Geometry (可変過給)	Y223	: 横浜ゴム(株)
V/S	: Vacuum Servo Brake (バキューム サーボ ブレーキ)	Y320	: ユシロ化学工業(株)
VAL	: Valve (バルブ)	Y325	: 輸送機工業株式会社
VEH	: Vehicle (車両)	Y699	: 三菱自動車工業(株)国内部品部
VELNAS	: Vehicle Electronic Navigation System (ビークル エレクトロニック ナビゲーション システム)	ZZ	: More Than 100 (100個以上)
VENT	: Ventilator (ベンチレータ)	Z025	: 自動車動力興業(株)
VES	: Video Entertainment System (ビデオ エンターテイメント システム)	Z030	: 自動車機器株式会社
		Z062	: (株)セクセル
		Z063	: (株)セクセル販売

1ST	: First (ファースト)
2ND	: Second (セカンド)
2WD	: Two Wheel Drive (2輪駆動)
3PT	: 3 Point (スリーポイント)
3RD	: Third (サード)
4TH	: Fourth (フォース)
4WD	: Four Wheel Drive (4輪駆動)
4WS	: Four Wheel Steering (4輪操舵)
50Hz/60Hz	: 50ヘルツ/60ヘルツ

目 次

CONTENTS

グループ番号 GROUP NO.	グループ名称 GROUP NAME	ページ PAGE
エンジン ENGINE		
11 -020	ショートエンジンアセンブリ SHORT ENGINE ASSY	2
11 -030	サービスシリンダヘッドアセンブリ SERVICE CYLINDER HEAD ASSY	4
11 -040	サービスシリンダブロックアセンブリ SERVICE CYLINDER BLOCK ASSY	6
11 -050	ライナ & ピストンキット LINER & PISTON KIT	8
11 -060	サービスクランクシャフトアセンブリ SERVICE CRANKSHAFT ASSY	10
11 -090	エンジンオーバーホールガスケットキット ENGINE OVERHAUL GASKET KIT	12
11 -110	ロッカカバー & ブリザ ROCKER COVER & BREATHER	14
11 -120	シリンダヘッド CYLINDER HEAD	16
11 -130	シリンダブロック CYLINDER BLOCK	18
11 -140	オイルパン、フィラー & ゲージ OIL PAN, FILLER & GAUGE	22
11 -150	フライホイール & ハウジング FLYWHEEL & HOUSING	24
11 -210	ピストン、コネクティングロッド & クランクシャフト PISTON, CONNROD & CRANKSHAFT	28
11 -230	カムシャフト & バルブ CAMSHAFT & VALVE	32
11 -240	タイミングギヤ TIMING GEAR	34
11 -340	エアコンプレッサ AIR COMPRESSOR	36
11 -410	アタッチングパーツ ATTACHING PARTS	44
ルブリケーション LUBRICATION		
12 -110	オイルポンプ & ストレーナ OIL PUMP & STRAINER	48
12 -120	オイルフィルタ OIL FILTER	50
12 -130	オイルクーラ OIL COOLER	52
12 -140	オイルライン OIL LINE	54
フュエル FUEL		
13 -030	フュエルフィルタ & ホース FUEL FILTER & HOSE	58
13 -110	フュエルインジェクションポンプゼネラル FUEL INJECTION PUMP GENERAL	60
13 -120	インジェクションポンプ INJECTION PUMP	62
13 -160	ガバナ GOVERNOR	68

目 次 CONTENTS

グループ番号 GROUP NO.	グループ名称 GROUP NAME	ページ PAGE
13 -270	オートマチックタイマ AUTOMATIC TIMER	74
13 -290	フューエルフィードポンプ FUEL FEED PUMP	76
13 -320	カップリング COUPLING	78
13 -410	インジェクションパイプ & ノズル INJECTION PIPE & NOZZLE	80
13 -420	フューエルリターンホース FUEL RETURN HOSE	88
クーリング COOLING		
14 -110	ウォーターポンプ & ファン WATER PUMP & FAN	90
14 -120	ウォーターパイプ & サーマスタット WATER PIPE & THERMOSTAT	92
インテーク & エキゾースト INTAKE & EXHAUST		
15 -210	インレットマニホールド INLET MANIFOLD	94
15 -310	エキゾーストマニホールド EXHAUST MANIFOLD	96
15 -410	ターボチャージャー TURBOCHARGER	98
エンジン電気系 ENGINE ELECTRICAL		
16 -010	スタータ STARTER	102
16 -110	オルタネータ & レギュレータ ALTERNATOR & REGULATOR	106
ステアリング STEERING		
37 -110	パワーステアリングオイルポンプ POWER STEERING OIL PUMP	110
キャブ & ボデー CAB & BODY		
42 -550	プレート & ラベル PLATE & LABEL	112
部品番号順索引 PARTS NUMBER INDEX		A1
部品名称順索引 PARTS NAME INDEX		B1

イラスト・部品番号リスト

Silverhorn.CO.UK

ショートエンジンアセンブリ
11 -020 SHORT ENGINE ASSY

-2-

01010A

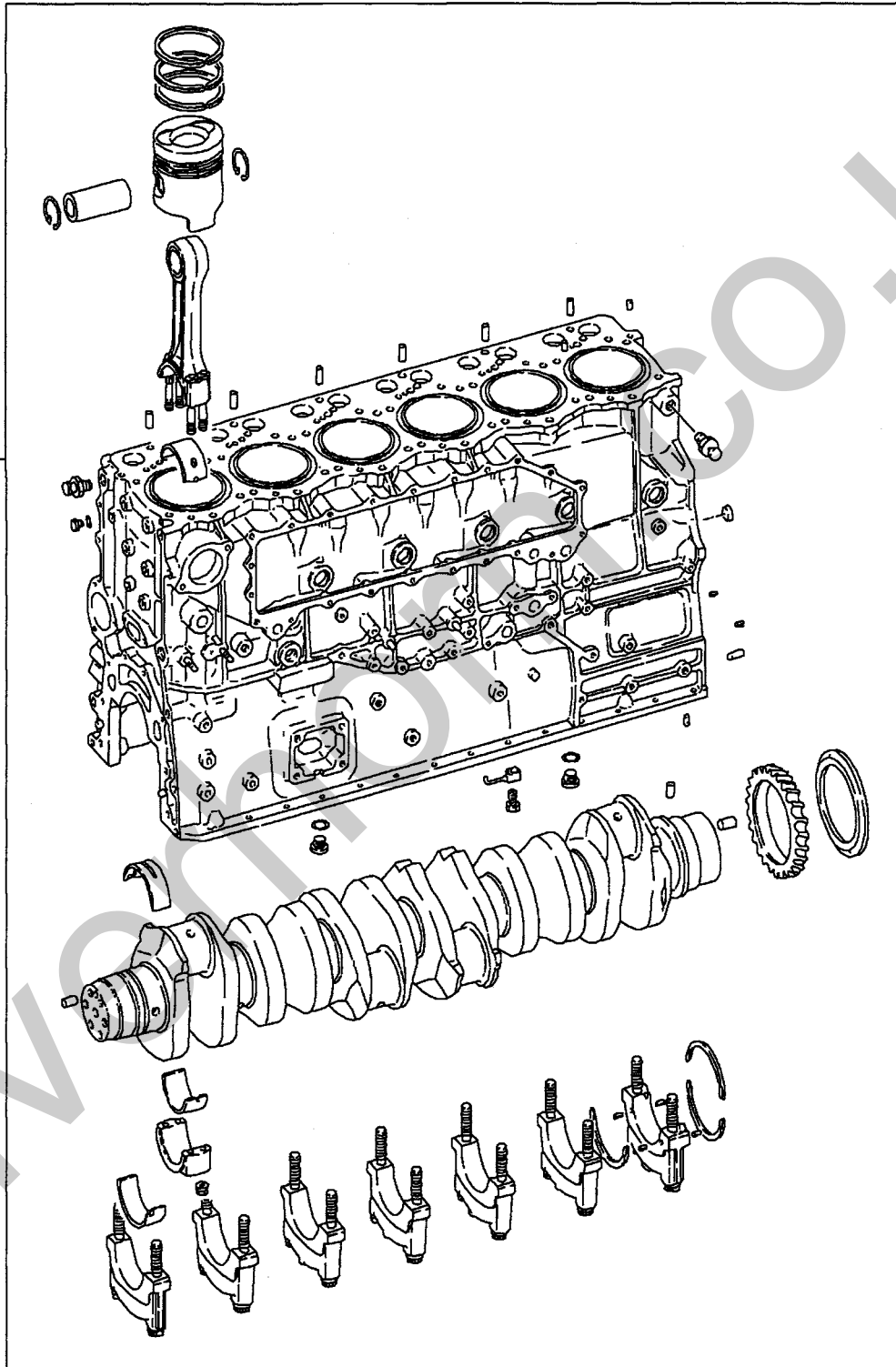

200T01

ショートエンジンアセンブリ
11 -020 SHORT ENGINE ASSY

01 6D240 CTJS07000

-3-

見出番号 REF.-NO.	部品番号 PART NO.	代 替 順 号 / P S C E N Q G	部品名称および記事・仕様記号 PART NAME & DESCRIPTION	型式・個数 MODEL & QTY						適用号機 APPLICABLE SERIAL NO.		管 区 M / R	新 規 V R D	
				0	1					FROM@-	@UPTO			
01010A	ME993459	3	ENGINE ASSY,SHORT	1							0105	0303		
	(ME993820)		ENGINE ASSY,SHORT	1							0304	1		
	ME993820													

サビシリンダ ヘッド アセンブリ
11 -030 SERVICE CYLINDER HEAD ASSY

-4-

01200A

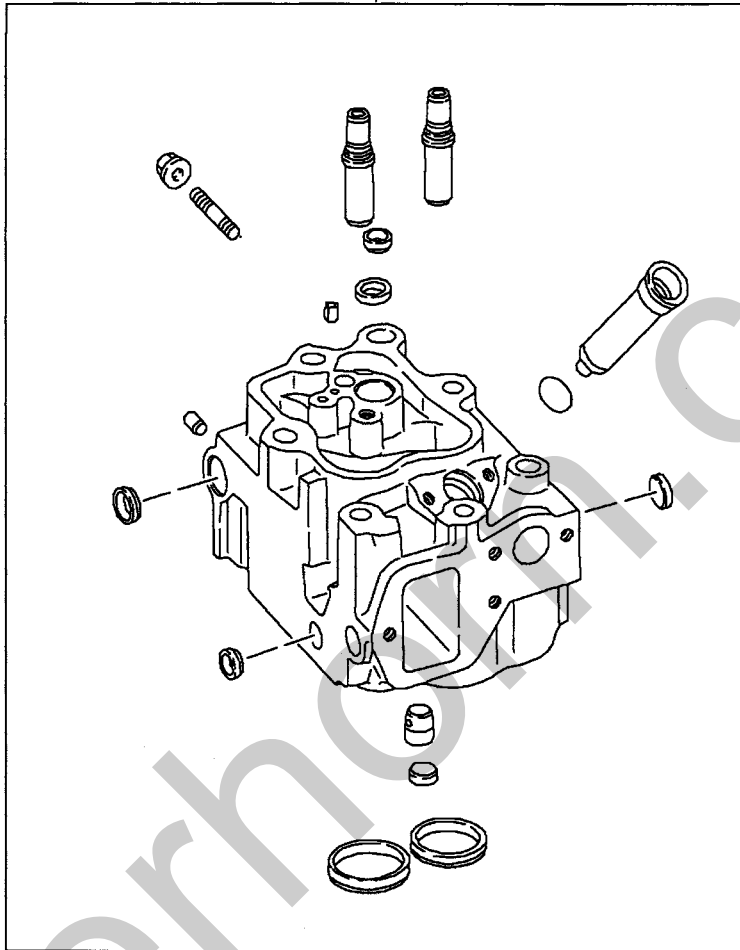

200T01

サビ`スシリンダ`ブ`ロックアセンブリ
11 -040 SERVICE CYLINDER BLOCK ASSY

-6-

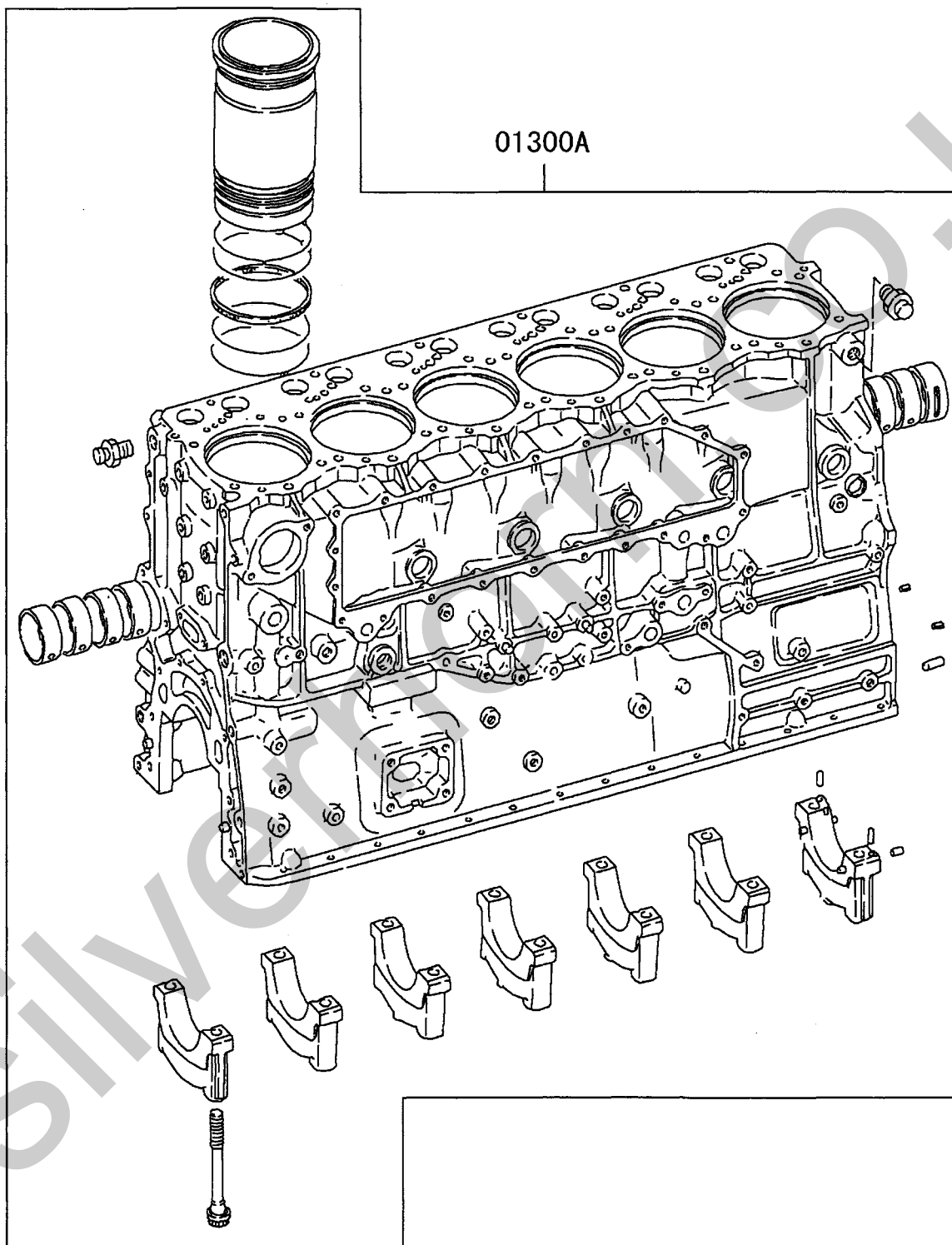

サービスシリンダブロックアセンブリ
11 -040 SERVICE CYLINDER BLOCK ASSY

01 6D240 CTJS07000

-7-

見出番号 REF.-NO.	部品番号 PART NO.	代 替 順 号 R S C / E N P Q G	部品名称および記事・仕様記号 PART NAME & DESCRIPTION	型式・個数 MODEL & QTY						適用号機 APPLICABLE SERIAL NO.		新 規 V R D	
				0	1					FROM@	@UPTO		
01300A	ME993092 (ME993779) ME993779	3	BLOCK ASSY,CYLINDER	1							0105-1	0303-3	
			BLOCK ASSY,CYLINDER	1							0304-1		

11 -050 ライナ & ピストンキット
LINER & PISTON KIT

-8-

01340

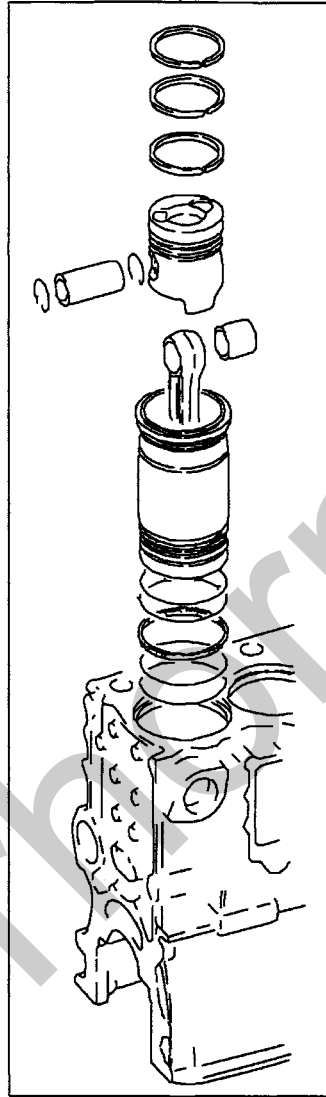

200T01

ライク&ピストンキット
11 -050 LINER & PISTON KIT

01 6D240 CTJS07000

-9-

見出番号 REF.-NO.	部品番号 PART NO.	代 替 R / P	変 更 順 号 S C E N E / Q Q	部品名称および記事・仕様記号 PART NAME & DESCRIPTION	型式・個数 MODEL & QTY				適用号機 APPLICABLE SERIAL NO.	管 区 M / R	新 規 V R D
					0	1			FROM@		
01340	ME993457			LINER & PISTON KIT 2CYL	0	1			0105		1

サービスクランクシャフトアセンブリ
11 -060 SERVICE CRANKSHAFT ASSY

-10-

03000A

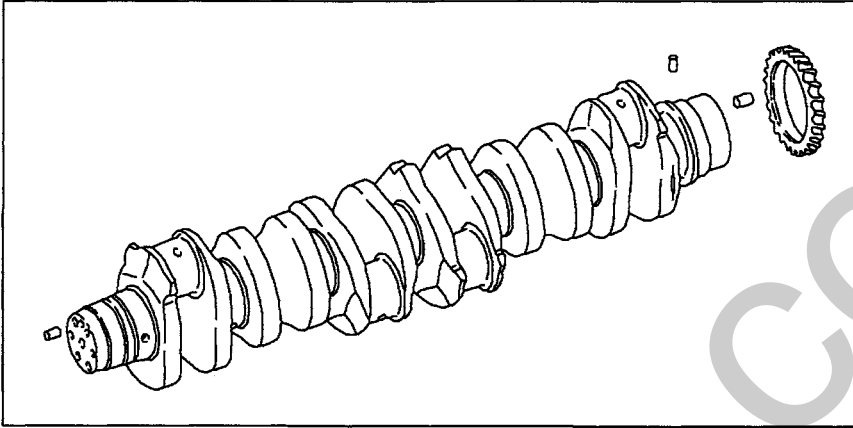

200T01

01070

エンジンオーバーホールガasketキットの部品番号は標準エンジン用です。標準と異なる装置が装着されている場合は、構成部品に過不足が生じますので予めご了承ください。

The part number of engine overhaul gasket kit is that of the kit used for the standard engine. Please note that if the engine is provided with equipment other than the standard one, there is a kit component shortage or overage.

ロッカカバ & フリザ
11 -110 ROCKER COVER & BREATHER

-14-

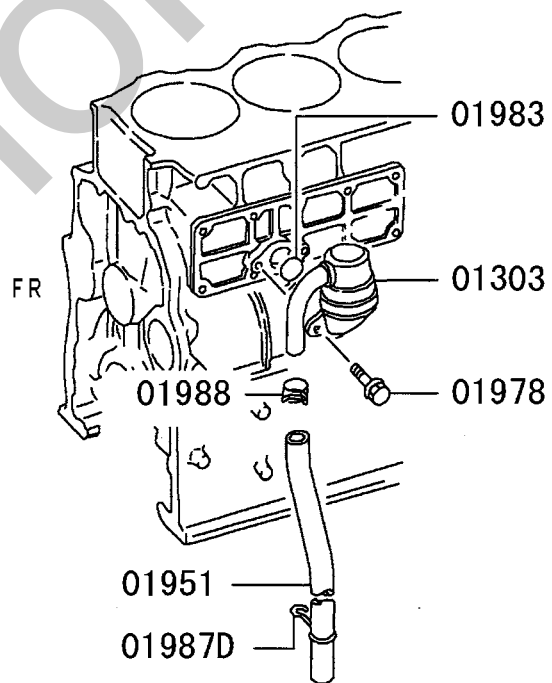
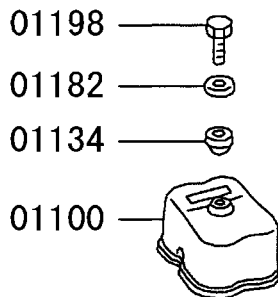

213T01

ロッキンガ - & ブリザ
11 -110 ROCKER COVER & BREATHER

01 6D240 CTJS07000

-15-

見出番号 REF.-NO.	部品番号 PART NO.	代 替 R / P	変 記 順 号 S C E N Q G	部品名称および記事・仕様記号 PART NAME & DESCRIPTION	型式・個数 MODEL & QTY					適用号機 APPLICABLE SERIAL NO.		管 区 M / R	新 規 V R D
					0	1					FROM@-		
01100	ME051694			COVER,ROCKER	6						0105-1		
01127	ME051373			O-RING,ROCKER COVER	6						0105-1		
01134	MD000523			SEAL,ROCKER COVER BOLT RUBBER	6						0105-1		
01182	ME051705			WASHER,ROCKER COVER 8.5	6						0105-1		
01198	MH001103			BOLT,ROCKER COVER 8X28	6						0105-1		
01303	ME054385	#		BREATHER,ENG T07156	1						0105-1		
01951	ME058989			HOSE,ENG BREATHER VINYL,24.5X1000	1						0105-1		
01978	MH000706			BOLT,ENG BREATHER FLANGE,10X16	2						0105-1		
01983	F315604500			O-RING,ENG BREATHER D=45	1						0105-1		
01987D	3004211900			CLIP,ENG BREATHER	1						0105-1		
01988	F430003201			CLAMP,ENG BREATHER D=30	1						0105-1		

11 -120 シリンダヘッド CYLINDER HEAD

-16-

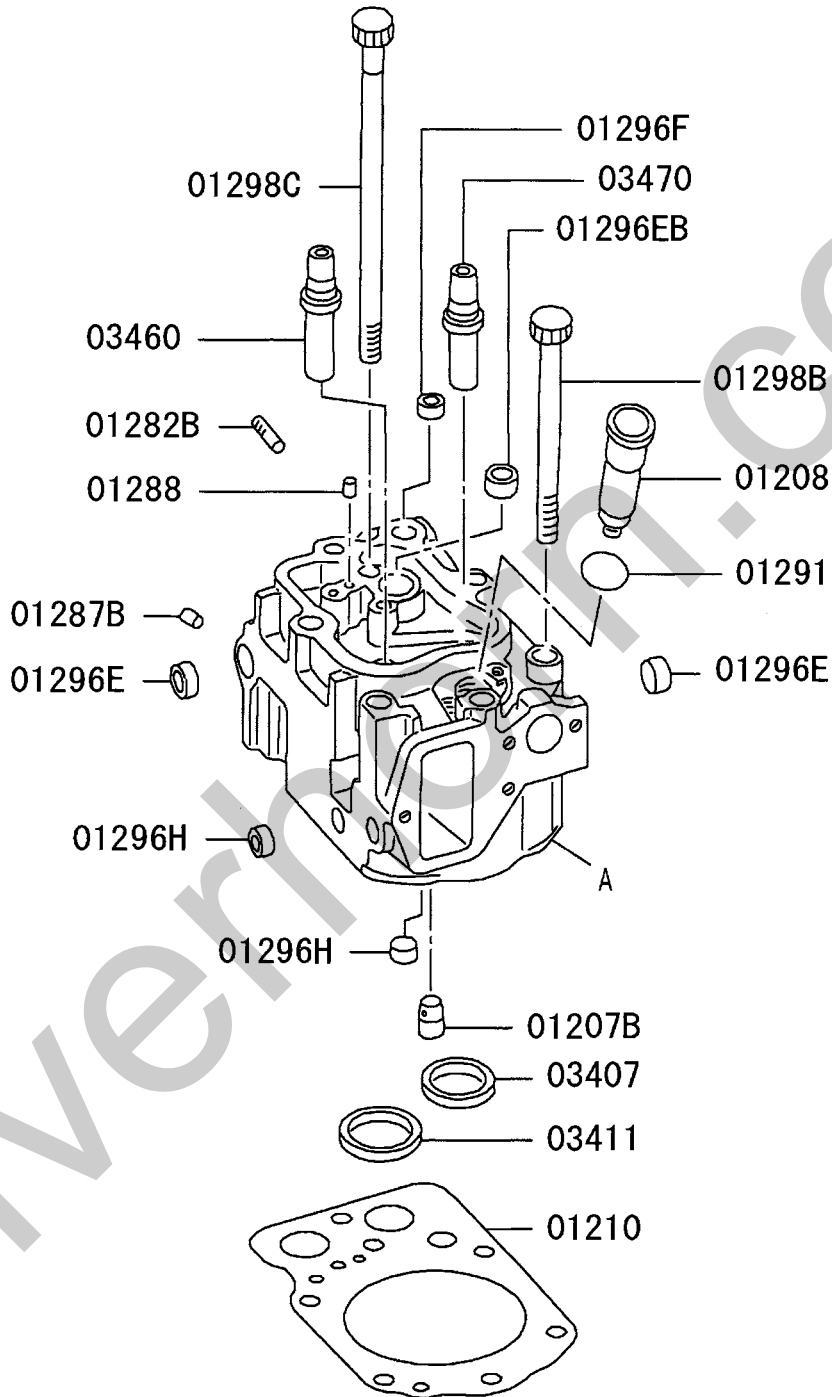

A: CYLINDER HEAD REF. 11-030

213T01

シリンダヘッド
11 -120 CYLINDER HEAD

01 6D240 CTJS07000

-17-

見出番号 REF.-NO.	部品番号 PART NO.	代 替 R / P 変 更 順 号 S C E N / Q G	部品名称および記事・仕様記号 PART NAME & DESCRIPTION	型式・個数 MODEL & QTY					適用号機 APPLICABLE SERIAL NO.		管 区 M / R 新 規 V R D
				0	1				FROM@-	@UPTO	
01207B	ME062523		DIRECTOR,CYLINDER HEAD WATER	6					0105-1		
01208	3090113709		TUBE,CYLINDER HEAD NOZZLE HOLDER	6					0105-1		
01210	ME051714		GASKET,CYLINDER HEAD	6					0105-1		
01282B	MH002131		STUD,CYLINDER HEAD 10X43	24					0105-1		
01287B	MH037762		PLUG,CYLINDER HEAD 11	6					0105-1		
01288	MF472585		SPRING PIN,CYLINDER HEAD 6X12	6					0105-1		
01291	MH035157		O-RING,CYLINDER HEAD 27	6					0105-1		
01296E	MS666137		CAP,CYLINDER HEAD SEALING,25	12					0105-1		
01296EB	MS666136		CAP,CYLINDER HEAD SEALING,D=22	6					0105-1		
01296F	MS666134		CAP,CYLINDER HEAD SEALING,18	6					0105-1		
01296H	MS666135		CAP,CYLINDER HEAD SEALING,20	12					0105-1		
01298B	ME051515		BOLT,CYLINDER HEAD FLANGE,14X181	36					0105-1		
01298C	ME051516		BOLT,CYLINDER HEAD FLANGE,14X249	6					0105-1		
03407	ME051354		SEAT,EXHAUST VALVE	6					0105-1		
03411	ME051300		SEAT,INLET VALVE FINISH SIZE	6					0105-1	0409-2	
	ME051587		SEAT,INLET VALVE FINISH SIZE	6					0409-3		
03460	ME051120		GUIDE,INLET VALVE	6					0105-1		
03470	ME051122		GUIDE,EXHAUST VALVE	6					0105-1		

シリンダブロック
 11 -130 CYLINDER BLOCK

-18-

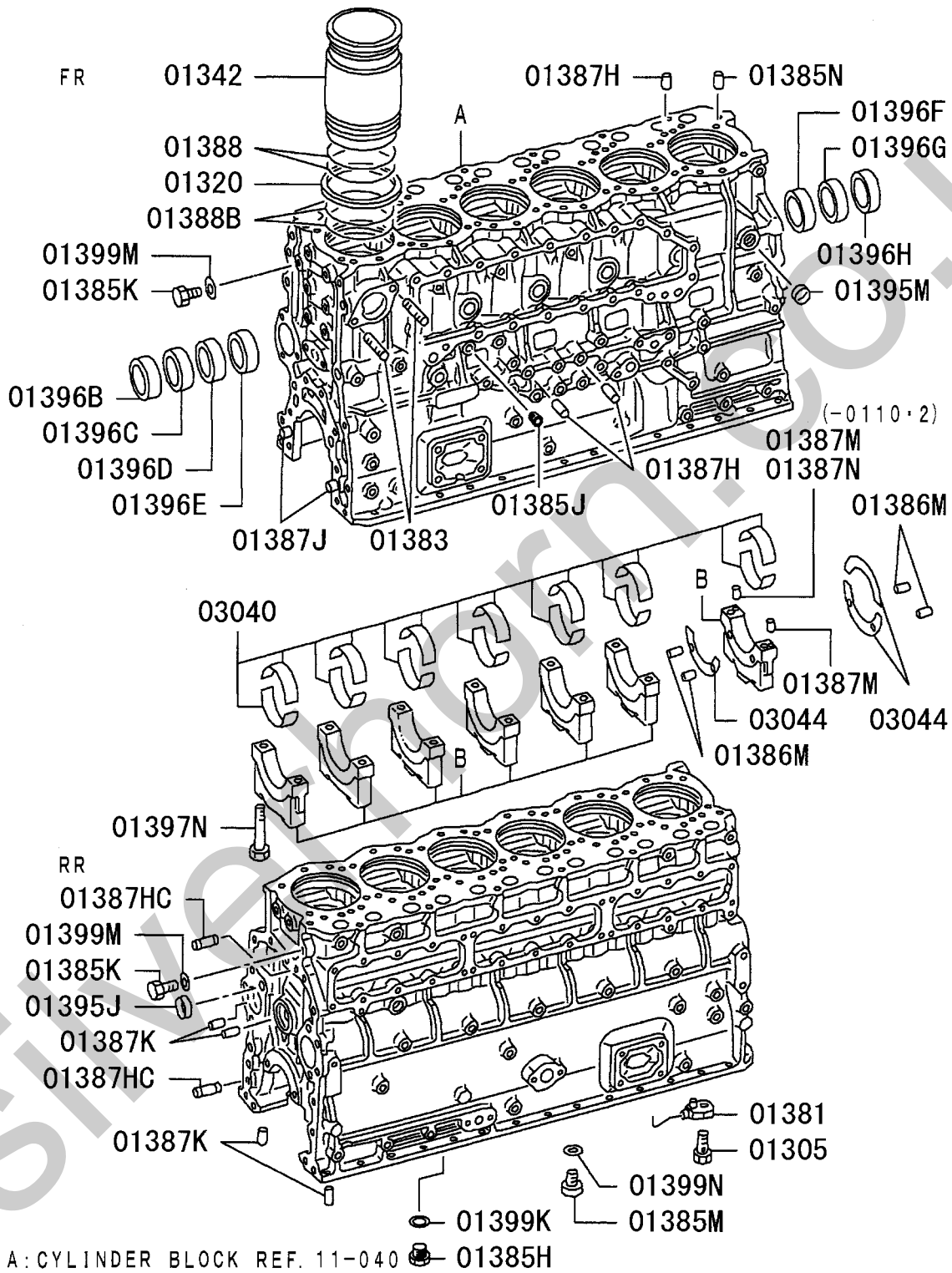

A: CYLINDER BLOCK REF. 11-040
 B: BEARING CAP REF. 11-040

213T01

シリンダブロック
11 -130 CYLINDER BLOCK

01 6D240 CTJS07000

-19-

見出番号 REF.-NO.	部品番号 PART NO.	代 替 R / P 記 順 号 S C E N Q G	部品名称および記事・仕様記号 PART NAME & DESCRIPTION	型式・個数 MODEL & QTY					適用号機 APPLICABLE SERIAL NO.		管 区 M / R 新 規 V / R D
				0	1				FROM@-	@UPTO	
01305	ME153215		CHECK VALVE,CYLINDER BLOCK PISTON LUBRIC	6					0105-1	0408-3	
	ME164831		CHECK VALVE,CYLINDER BLOCK PISTON LUBRIC	6					0409-1		
01320	3090722300		SEAL,CYLINDER LINER RUBBER	6					0105-1		
01342	ME051632		LINER,CYLINDER A SIZE	6					0105-1		
	ME051633		LINER,CYLINDER B SIZE	6					0105-1		
	ME051634		LINER,CYLINDER C SIZE	6					0105-1		
01381	ME150482		OIL JET,CYLINDER BLOCK	6					0105-1		
01383	F145010030		STUD,CYLINDER BLOCK 10X30	2					0105-1		
01385H	MH037137		PLUG,CYLINDER BLOCK SCREW,20	1					0105-1	0303-3	
	ME351466		PLUG,CYLINDER BLOCK 24	1					0304-1		
01385J	MH037725		PLUG,CYLINDER BLOCK TAPER,1/8	1					0105-1	0203-3	
	MH037788		PLUG,CYLINDER BLOCK TAPER,1/8	1					0204-1		
01385K	ME031088		PLUG,CYLINDER BLOCK SCREW,10	2					0105-1		
01385M	MH037137		PLUG,CYLINDER BLOCK SCREW,20	1					0105-1		
01385N	3090702800		PLUG,CYLINDER BLOCK 10	1					0105-1		
01386M	MH012037		SPRING PIN,CYLINDER BLOCK 5X10	6					0105-1		
01387H	MF472405		PIN,CYLINDER BLOCK DOWEL,10X20	14					0105-1		
01387HC	MH007011		PIN,CYLINDER BLOCK DOWEL,12X34	2					0105-1		
01387J	MF472406		PIN,CYLINDER BLOCK DOWEL,12X24	2					0105-1		
01387K	MF472404		PIN,CYLINDER BLOCK DOWEL,8X18	4					0105-1		
01387M	MH007009		PIN,CYLINDER BLOCK DOWEL,8X25	2					0105-1	0110-2	
	MH007009		PIN,CYLINDER BLOCK DOWEL,8X25	1					0110-3		
01387N	MH007008		PIN,CYLINDER BLOCK DOWEL,8X25	1					0110-3		
01388	ME153319		O-RING,CYLINDER BLOCK 142	12					0105-1		
01388B	ME151039		O-RING,CYLINDER BLOCK 138	12					0105-1		
01395J	F501428000		CAP,CYLINDER BLOCK SEALING,28	1					0105-1		
01395M	MS666137		CAP,CYLINDER BLOCK	1					0105-1		

シリンダブロック
11 -130 CYLINDER BLOCK

01 6D240 CTJS07000

-20-

見出番号 REF.-NO.	部品番号 PART NO.	代 替 R / P 記 順 号 S C E N Q G	部品名称および記事・仕様記号 PART NAME & DESCRIPTION	型式・個数 MODEL & QTY				適用号機 APPLICABLE SERIAL NO.		管 区 M / R 新 規 V R D
				0	1			FROM@-	@UPTO	
			SEALING,25		1					
01396B	ME051672		BUSHING,CYLINDER BLOCK		1				0105-1	
01396C	ME051673		BUSHING,CYLINDER BLOCK		1				0105-1	
01396D	ME051674		BUSHING,CYLINDER BLOCK		1				0105-1	
01396E	ME051675		BUSHING,CYLINDER BLOCK		1				0105-1	
01396F	ME051676		BUSHING,CYLINDER BLOCK		1				0105-1	
01396G	ME051677		BUSHING,CYLINDER BLOCK		1				0105-1	
01396H	ME051678		BUSHING,CYLINDER BLOCK		1				0105-1	
01397N	ME180041		BOLT,CYLINDER BLOCK 18X154		14				0105-1	
01399K	MH035077		GASKET,CYLINDER BLOCK 20		1				0105-1	0303-3
	ME351484		GASKET,CYLINDER BLOCK 24		1				0304-1	
01399M	F420210000		GASKET,CYLINDER BLOCK D=10		2				0105-1	
01399N	MH035077		GASKET,CYLINDER BLOCK 20		1				0105-1	
03040	ME350864	3	BEARING SET,CRANKSHAFT PLAIN,STD		1				0105-1	0803-3
	(ME994204) ME350865	3	BEARING SET,CRANKSHAFT PLAIN,U/SIZE 0.25		1				0105-1	0803-3
	(ME994205) ME350866	3	BEARING SET,CRANKSHAFT PLAIN,U/SIZE 0.50		1				0105-1	0803-3
	(ME994206) ME350867	3	BEARING SET,CRANKSHAFT PLAIN,U/SIZE 0.75		1				0105-1	0803-3
	(ME994207) ME350868	3	BEARING SET,CRANKSHAFT PLAIN,U/SIZE 1.00		1				0105-1	0803-3
	(ME994208) ME994204		BEARING SET,CRANKSHAFT STD		1				0804-1	
	ME994205		BEARING SET,CRANKSHAFT U/SIZE 0.25		1				0804-1	
	ME994206		BEARING SET,CRANKSHAFT U/SIZE 0.50		1				0804-1	
	ME994207		BEARING SET,CRANKSHAFT U/SIZE 0.75		1				0804-1	
	ME994208		BEARING SET,CRANKSHAFT U/SIZE 1.00		1				0804-1	
03044	3120978101		PLATE,CRANKSHAFT THRUST STD		3				0105-1	
	3120978201		PLATE,CRANKSHAFT THRUST O/SIZE 0.15		3				0105-1	
	3120978301		PLATE,CRANKSHAFT THRUST O/SIZE 0.30		3				0105-1	
	3120978401		PLATE,CRANKSHAFT THRUST		3				0105-1	

シリンダブロック
11 -130 CYLINDER BLOCK

01 6D240 CTJS07000

-21-

見出番号 REF.-NO.	部品番号 PART NO.	代 替 順 号 R / P	記 号 S C E N Q G	部品名称および記事・仕様記号 PART NAME & DESCRIPTION	型式・個数 MODEL & QTY				適用号機 APPLICABLE SERIAL NO.		管 区 M / R	新 規 V R D
					0	1			FROM@	@UPTO		
				O/SIZE 0.45								

オイルパン、フイラ&ゲージ
11 -140 OIL PAN, FILLER & GAUGE

-22-

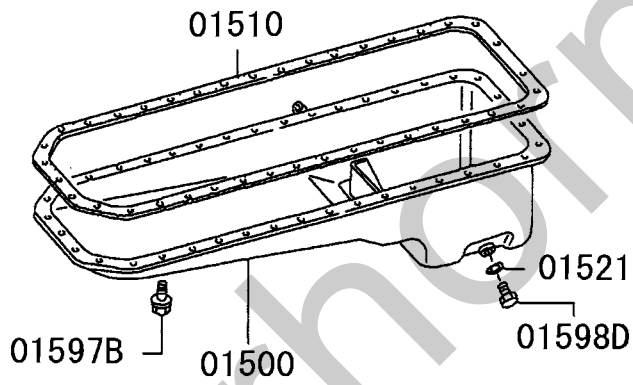
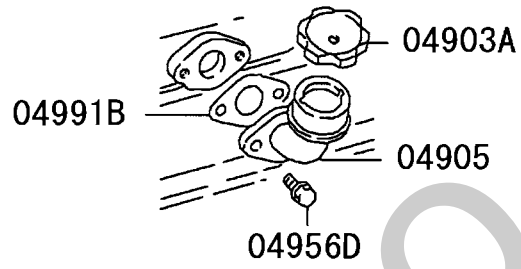
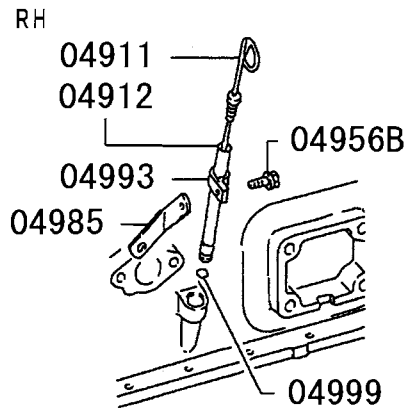

213T01

11 -140 OIL PAN,FILLER & GAUGE

オイルパン、フイラー & ゲージ

01 6D240 CTJS07000

-23-

見出番号 REF.-NO.	部品番号 PART NO.	代 替 R / P	変 記 順 号 S C E N E Q G	部品名称および記事・仕様記号 PART NAME & DESCRIPTION	型式・個数 MODEL & QTY					適用号機 APPLICABLE SERIAL NO.		管 区 M / R	新 規 V / R D	
					0	1					FROM@-			@UPTO
01500	ME158178			OIL PAN,ENG	1						0105-1			
01510	ME152344			GASKET,ENG OIL PAN	1						0105-1			
01521	MH035018			GASKET,ENG OIL PAN DRAIN PLUG 18	1						0105-1			
01597B	MH000931			BOLT,ENG OIL PAN FLANGE,10X18	37						0105-1	0206-3		
	MF303363			BOLT,ENG OIL PAN WASHER ASSEMBLED,10X25	2						0105-1	0206-3		
	MS146003			BOLT,ENG OIL PAN FLANGE,10X18	37						0207-1			
	MH001785			BOLT,ENG OIL PAN FLANGE,10X25	2						0207-1			
01598D	MH037126			PLUG,ENG OIL PAN SCREW,18	1						0105-1			
04903A	MD008784 (MN143845)	3		CAP ASSY,ENG OIL FILLER	1						0105-1			
04905	ME058900			FILLER,ENG OIL	1						0105-1			
04911	ME158181			GAUGE,ENG OIL LEVEL	1						0105-1			
04912	ME157032			GUIDE,ENG OIL LEVEL GAUGE	1						0105-1			
04956B	MH000999			BOLT,ENG OIL FILLER FLANGE,6X12	1						0105-1			
04956D	MS146004			BOLT,ENG OIL FILLER FLANGE,10X20	2						0105-1			
04985	MH023799			STAY,ENG OIL FILLER	1						0105-1			
04991B	ME150060			GASKET,ENG OIL FILLER	1						0105-1			
04993	MH021015			CLAMP,ENG OIL FILLER D=12.2	1						0105-1			
04999	MH035225 (MH035242)	3		O-RING,ENG OIL FILLER 11	1						0105-1	0209-3		
	MH035242			O-RING,ENG OIL FILLER 10.8	1						0210-1			

FLYWHEEL HOUSING

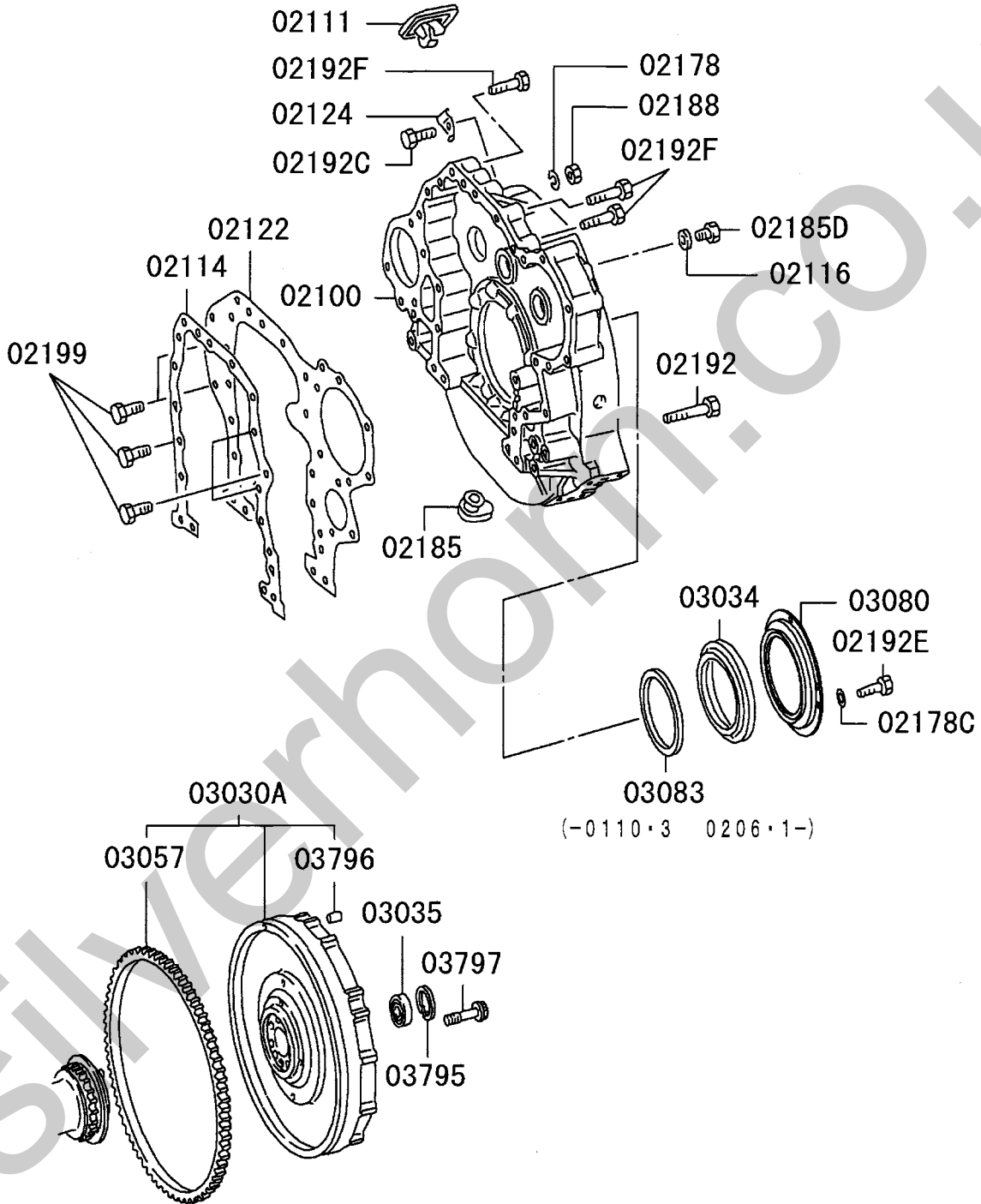

TACHOMETER DRIVE

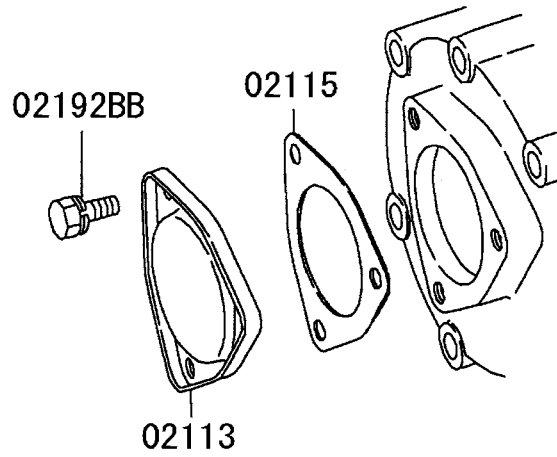

Silverhorn.CO.UK

フライホイール & ハウジング
11 -150 FLYWHEEL & HOUSING

01 6D240 CTJS07000

-26-

見出番号 REF.-NO.	部品番号 PART NO.	代 替 R / P 変 更 順 号 S C E N Q G	部品名称および記事・仕様記号 PART NAME & DESCRIPTION	型式・個数 MODEL & QTY					適用号機 APPLICABLE SERIAL NO.		管 区 M / R 新 規 V R D
				0	1				FROM@-	@UPTO	
02100	ME152602		HOUSING,FLYWHEEL	1					0105-1		
02111	3121202300 (ME151267)	R	COVER,FLYWHEEL HOUSING TIMING POINTER	1					0105-1	0109-3	
	ME151267		COVER,FLYWHEEL HOUSING TIMING POINTER	1					0110-1		
02113	3111204100		COVER,FLYWHEEL HOUSING,RR	1					0105-1		
02114	ME150048		GASKET,ENG RR PLATE CYLINDER BLOCKSIDE	1					0105-1		
02115	3111204200		GASKET,FLYWHEEL HOUSING RR COVER	1					0105-1		
02116	F420216000		GASKET,FLYWHEEL HOUSING D=16	1					0105-1		
02122	ME052661		PLATE,CYLINDER BLOCK,RR	1					0105-1		
02124	ME061699		POINTER,FLYWHEEL HOUSING ENG TIMING	1					0105-1		
02178	F251506000		WASHER,FLYWHEEL HOUSING SPRING,6	1					0105-1		
02178C	F250008000		WASHER,FLYWHEEL HOUSING PLAIN,8	4					0105-1		
02185	3091201400		PLUG,FLYWHEEL HOUSING RUBBER,29	1					0105-1		
02185D	M0001300 (MB001260)	3	PLUG,FLYWHEEL HOUSING SCREW,D=16	1					0105-1		
02188	F230006000		NUT,FLYWHEEL HOUSING 6	1					0105-1		
02192	MS146065		BOLT,FLYWHEEL HOUSING FLANGE,12X90	8					0105-1		
02192BB	MF300841		BOLT,FLYWHEEL HOUSING WASHER ASSEMBLED,10X20	3					0105-1		
02192C	F102506025		BOLT,FLYWHEEL HOUSING 6X25	1					0105-1		
02192E	MF240050		BOLT,FLYWHEEL HOUSING WASHER ASSEMBLED,8X14	4					0105-1		
02192F	MS146059		BOLT,FLYWHEEL HOUSING FLANGE,12X60	5					0105-1		
02199	MH000733		BOLT,ENG RR PLATE FLANGE,12X20	4					0105-1	0209-3	
	MS146051		BOLT,ENG RR PLATE FLANGE,12X20	9					0105-1		
03030A	ME150497 (ME151859)	3	FLYWHEEL ASSY	1					0105-1		
03034	3092020100	#	OIL SLINGER,CRANKSHAFT,RR T02468A	1					0105-1	0108-2	
	ME351469		OIL SLINGER,CRANKSHAFT,RR	1					0108-3	0110-3	
	3092020100	#	OIL SLINGER,CRANKSHAFT,RR T02468A	1					0111-1	0205-3	
	ME351469		OIL SLINGER,CRANKSHAFT,RR	1					0206-1		
03035	MH040026		BEARING,FLYWHEEL DRIVE PINION BALL	1					0105-1		
03057	ME062828		RING GEAR,FLYWHEEL N=143	1					0105-1	0202-3	
	ME351296		RING GEAR,FLYWHEEL	1					0203-1		

11 -150 FLYWHEEL & HOUSING

フライホイール & ハウジング

01 6D240 CTJS07000

-27-

見出番号 REF.-NO.	部品番号 PART NO.	代 替 順 号 R P /	記 号 S C E N Q G	部品名称および記事・仕様記号 PART NAME & DESCRIPTION	型式・個数 MODEL & QTY				適用号機 APPLICABLE SERIAL NO.		管 区 M / R	新 規 V R D
					0	1			FROM@-	@UPTO		
03080	ME152584			N=143 OIL SEAL,CRANKSHAFT,RR	1					0105-1		
03083	ME351471 (ME351837)	3		RING,CRANKSHAFT RR OIL SLINGER	1					0108-3 0110-3		
	ME352391			RING,CRANKSHAFT RR OIL SLINGER	1					0206-1		
03795	F320206200			SNAP RING,FLYWHEEL	1					0105-1		
				D=62								
03796	MF472405			PIN,FLYWHEEL	2					0105-1		
				DOWEL,10X20								
03797	ME052691			BOLT,FLYWHEEL	8					0105-1		
				FLANGE,16X50.5								

ピストン、コネクティングロッド & クランクシャフト
 11-210 PISTON, CONNROD & CRANKSHAFT

-28-

PISTON, CONNECTING ROD

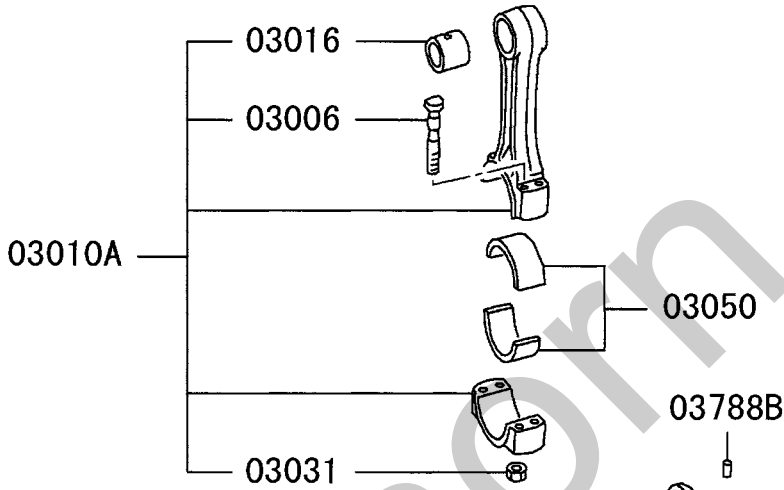
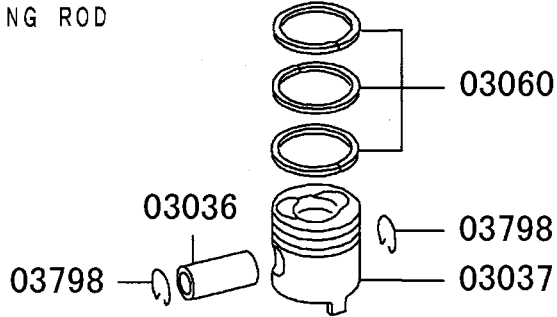

CRANKSHAFT, PULLEY

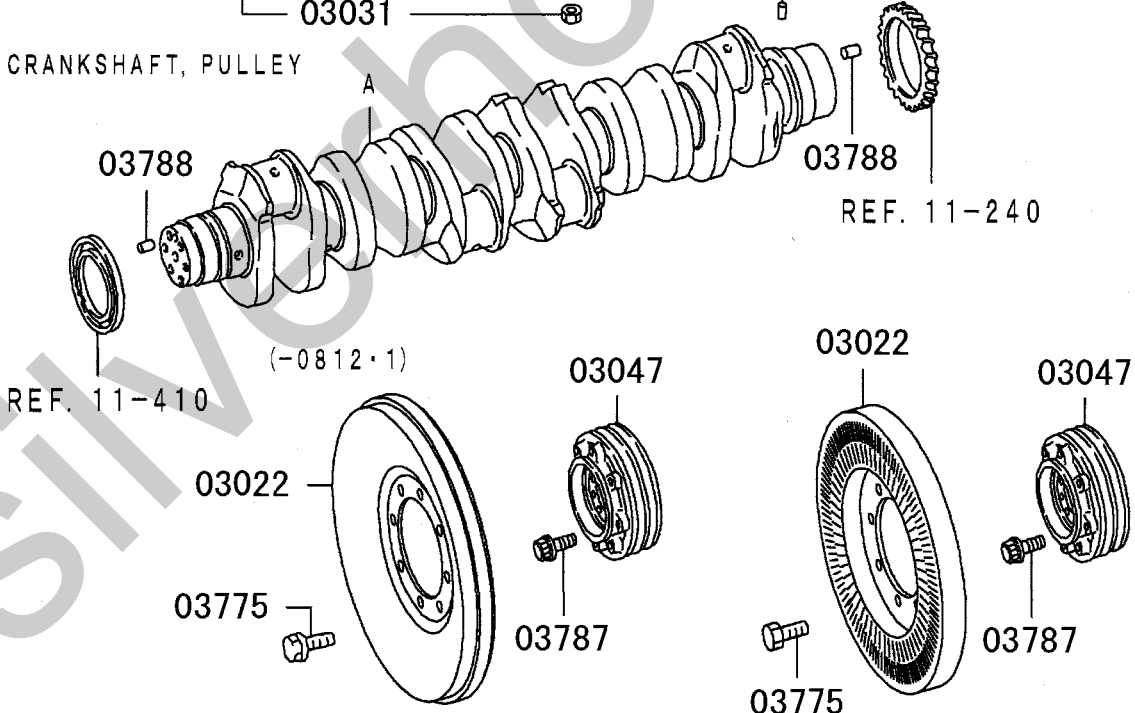

A: CRANKSHAFT REF. 11-060

213T01

ピストン,コネクティングロッド & クランクシャフト
11 -210 PISTON,CONNROD & CRANKSHAFT

01 6D240 CTJS07000

-29-

見出番号 REF.-NO.	部品番号 PART NO.	代 替 R / P 変 記 順 号 S C / E N Q G	部品名称および記事・仕様記号 PART NAME & DESCRIPTION	型式・個数 MODEL & QTY					適用号機 APPLICABLE SERIAL NO.		新 規 V R D 管 区 M / R
				0	1				FROM@-	@UPTO	
03006	ME052765		BOLT,CONNROD 13X107	24					0105-1		
03010A	ME150493		CONNECTING ROD ASSY	6					0105-1	0510-3	
	ME357130		CONNECTING ROD ASSY	6					0511-1		
03016	ME151450		BUSHING,CONNROD	6					0105-1		
03022	ME121799	#	DAMPER,CRANKSHAFT TORSIONAL T02013B	1					0105-1	0407-1	
	ME150849		DAMPER,CRANKSHAFT TORSIONAL	1					0407-2	0812-1	
	ME359097		DAMPER,CRANKSHAFT TORSIONAL	1					0812-2		V
03031	ME032042		NUT,CONNROD FLANGE,13	24					0105-1		
03036	ME052149		PIN,PISTON 50X106	6					0105-1		
03037	ME158100		PISTON O/SIZE 0.50	6					0105-1		
	ME158101		PISTON O/SIZE 0.75	6					0105-1		
	ME158102		PISTON O/SIZE 1.00	6					0105-1		
	ME158097		PISTON A SIZE	6					0105-1		
	ME158098		PISTON B SIZE	6					0105-1		
	ME158099		PISTON C SIZE	6					0105-1		
03047	ME058316		PULLEY,CRANKSHAFT	1					0105-1		
03050	ME181337	#	BEARING SET,CONNROD STD T08014	1					0105-1	0604-3	
	ME181338	#	BEARING SET,CONNROD U/SIZE 0.25 T08014	1					0105-1	0604-3	
	ME181339	#	BEARING SET,CONNROD U/SIZE 0.50 T08014	1					0105-1	0604-3	
	ME181340	#	BEARING SET,CONNROD U/SIZE 0.75 T08014	1					0105-1	0604-3	
	ME181341	#	BEARING SET,CONNROD U/SIZE 1.00 T08014	1					0105-1	0604-3	
	ME994419		BEARING SET,CONNROD STD	1					0605-1		
	ME994420		BEARING SET,CONNROD U/SIZE 0.25	1					0605-1		
	ME994421		BEARING SET,CONNROD U/SIZE 0.50	1					0605-1		
	ME994422		BEARING SET,CONNROD U/SIZE 0.75	1					0605-1		
	ME994423		BEARING SET,CONNROD U/SIZE 1.00	1					0605-1		
03060	ME350786		RING SET,PISTON STD	1					0105-1		
	ME350787		RING SET,PISTON O/SIZE 0.50	1					0105-1		

カムシャフト & バルブ
11 -230 CAMSHAFT & VALVE

-32-

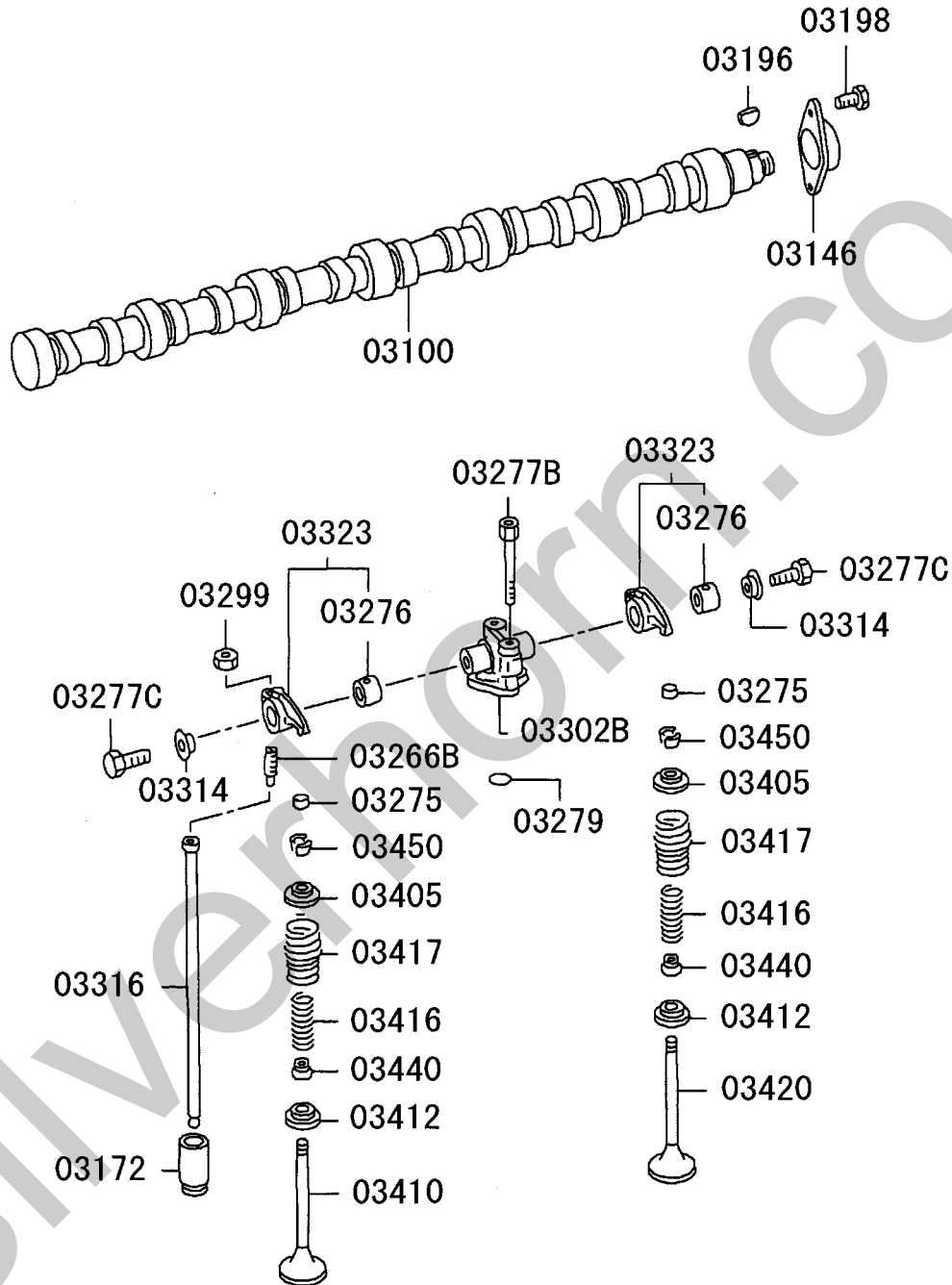

213T01

11 -230 CAMSHAFT & VALVE

カムシャフト & バルブ

01 6D240 CTJS07000

-33-

見出番号 REF.-NO.	部品番号 PART NO.	代 替 R / P 記 順 号 S C E N Q G	部品名称および記事・仕様記号 PART NAME & DESCRIPTION	型式・個数 MODEL & QTY					適用号機 APPLICABLE SERIAL NO.		管 区 M / R	新 規 V R D
				0	1				FROM@-	@UPTO		
03100	ME151299		CAMSHAFT	1					0105-1			
03146	ME151300		PLATE,CAMSHAFT THRUST	1					0105-1			
03172	ME061021		TAPPET,VALVE	12					0105-1			
03196	F287005019		KEY,CAMSHAFT WOODRUFF,5X19	1					0105-1			
03198	MH000714		BOLT,CAMSHAFT FLANGE,10X25	2					0105-1	0304-3		
	MS146306		BOLT,CAMSHAFT FLANGE,10X25	2					0305-1			
03266B	ME051584	3	SCREW,VALVE GEAR TRAIN TAPPING,10X45	12					0105-1	0109-3		
	(ME351744) ME351744		SCREW,VALVE GEAR TRAIN 10X43	12					0110-1			
03275	3000424302		CAP,VALVE GEAR TRAIN 12	12					0105-1			
03276	3090402200		BUSHING,VALVE GEAR TRAIN	12					0105-1			
03277B	ME152008		BOLT,VALVE GEAR TRAIN 10X84	6					0105-1			
03277C	MF241222		BOLT,VALVE GEAR TRAIN WASHER ASSEMBLED,6X10	12					0105-1			
03279	MH035135		O-RING,VALVE GEAR TRAIN 17	6					0105-1			
03299	F230510000		NUT,VALVE GEAR TRAIN 10	12					0105-1			
03302B	ME150511		BRACKET,ROCKER SHAFT	6					0105-1			
03314	3090401600		PLATE,ROCKER SHAFT THRUST	12					0105-1			
03316	ME051180		PUSH ROD,ROCKER ARM	12					0105-1			
03323	ME051051		ROCKER ARM,INLET & EXHAUST VALVE	12					0105-1			
03405	ME095645		RETAINER,VALVE SPRING	12					0105-1			
03410	ME051696		VALVE,INLET	6					0105-1	0409-2		
	ME051698		VALVE,INLET	6					0409-3			
03412	ME051083		SEAT,VALVE SPRING	12					0105-1			
03416	ME061398		SPRING,VALVE,INR	12					0105-1			
03417	ME051208		SPRING,VALVE,OTR	12					0105-1			
03420	ME051697		VALVE,EXHAUST	6					0105-1			
03440	ME153274		SEAL,VALVE STEM	12					0105-1			
03450	3120434200		LOCK,VALVE SPRING RETAINER	24					0105-1			

11-240 TIMING GEAR

-34-

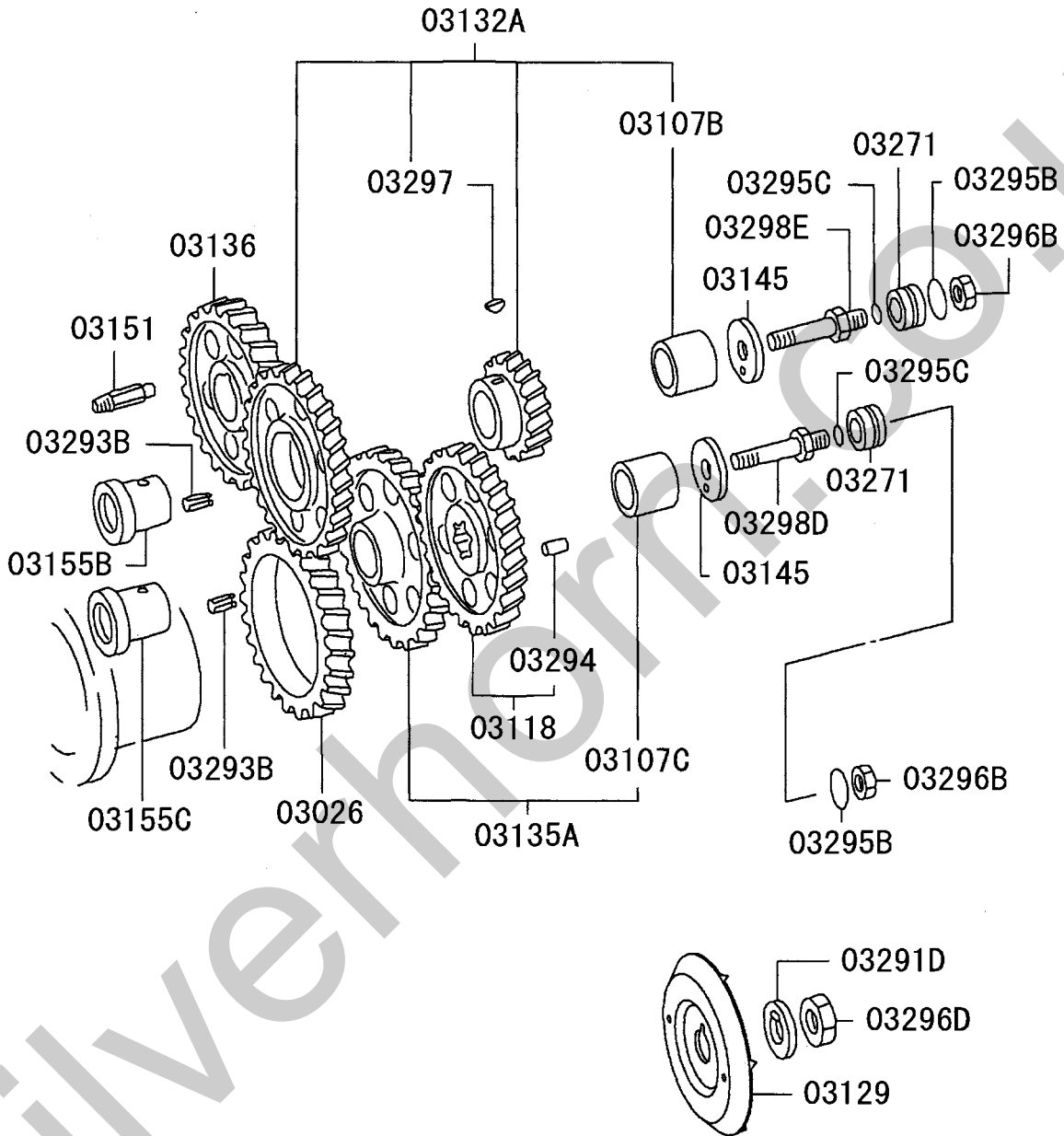

タイミンギヤ
11 -240 TIMING GEAR

01 6D240 CTJS07000

-35-

見出番号 REF.-NO.	部品番号 PART NO.	代 替 順 号 R S C / E N P Q G	変 記 号 S C / E N P Q G	部品名称および記事・仕様記号 PART NAME & DESCRIPTION	型式・個数 MODEL & QTY				適用号機 APPLICABLE SERIAL NO.	管 区 M / R	新 規 V R D
					0	1			FROM@- :@UPTO		
03026	ME093097			GEAR,CRANKSHAFT N=63	1				0105-1		
03107B	ME062905			BUSHING,TIMING GEAR TRAIN 43X44	1				0105-1		
03107C	ME052843			BUSHING,TIMING GEAR TRAIN 51X50	1				0105-1		
03118	ME052916			GEAR,INJECTION PUMP DRIVE N=63	1				0105-1		
03129	ME158303			PLATE,INJECTION PUMP DRIVE GEAR	1				0105-1		
03132A	ME150506			GEAR ASSY,CAM IDLER N=33,66	1				0105-1		
03135A	ME150689			GEAR ASSY,INJECTION PUMP IDLER N=68	1				0105-1		
03136	ME151298			GEAR,CAMSHAFT N=63	1				0105-1		
03145	ME062326			PLATE,CAM IDLER GEAR THRUST	2				0105-1		
03151	3090702900			PLUG,TIMING GEAR TRAIN TAPER	1				0105-1		
03155B	ME150519			SHAFT,CAM IDLER GEAR	1				0105-1		
03155C	ME150520			SHAFT,CAM IDLER GEAR	1				0105-1		
03271	ME062573			COLLAR,TIMING GEAR TRAIN	2				0105-1		
03291D	3117502109			WASHER,TIMING GEAR TRAIN LOCK,24	1				0105-1		
03293B	MH012037			SPRING PIN,TIMING GEAR TRAIN 5X10	2				0105-1		
03294	MF472402			PIN,TIMING GEAR TRAIN DOWEL,5X12	2				0105-1		
03295B	F315603500			O-RING,TIMING GEAR TRAIN 35	2				0105-1		
03295C	3112304100			O-RING,TIMING GEAR TRAIN D=15	2				0105-1		
03296B	F230516000			NUT,TIMING GEAR TRAIN 16	2				0105-1		
03296D	MH004075			NUT,TIMING GEAR TRAIN JAM,24	1				0105-1		
03297	F287005019			KEY,TIMING GEAR TRAIN WOODRUFF,5X19	1				0105-1		
03298D	ME150508			BOLT,TIMING GEAR TRAIN 16X88	1				0105-1		
03298E	ME150509			BOLT,TIMING GEAR TRAIN	1				0105-1		

17 コンプレッサ
11 -340 AIR COMPRESSOR

-36-

AIR COMPRESSOR (FOR 1CYL)

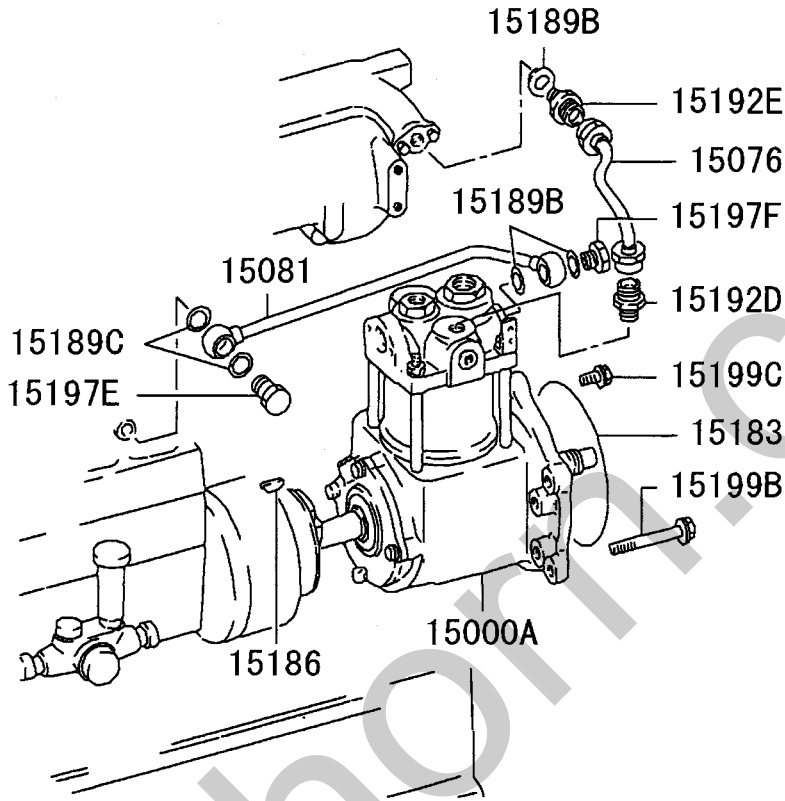

213T01

AIR OUTLET PIPE (FOR 1CYL)

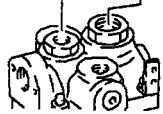
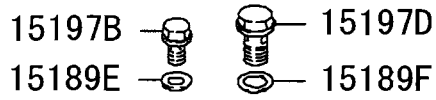

AIR SUCTION PIPE (FOR 1CYL)
(-0204・3)

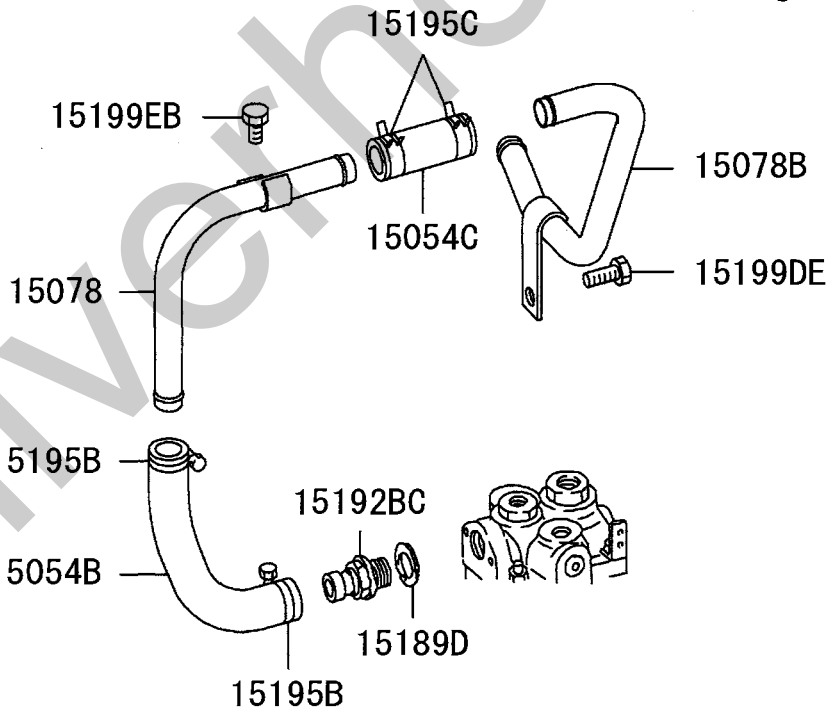
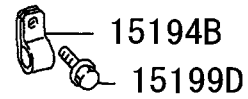
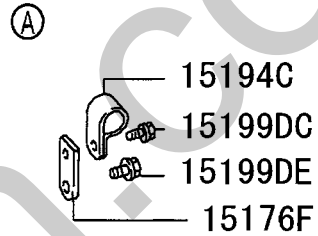
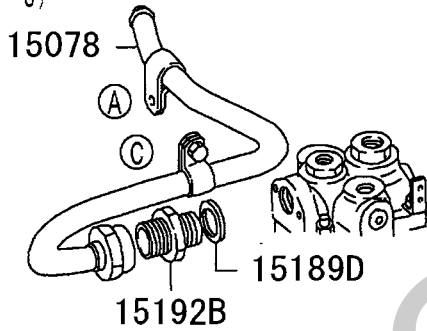

INNER PARTS

15000A

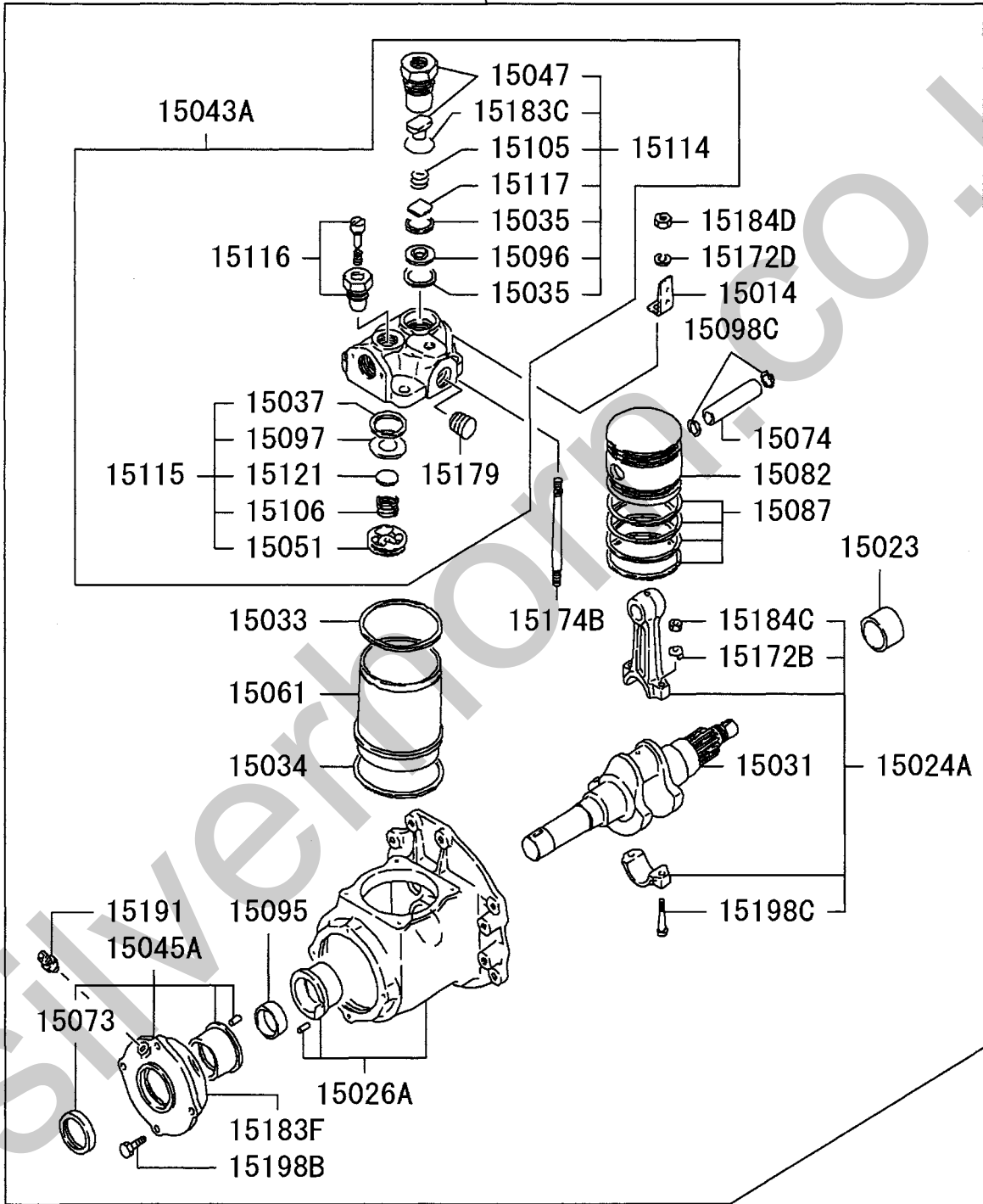

INNER PARTS (-0408・3)

15000A

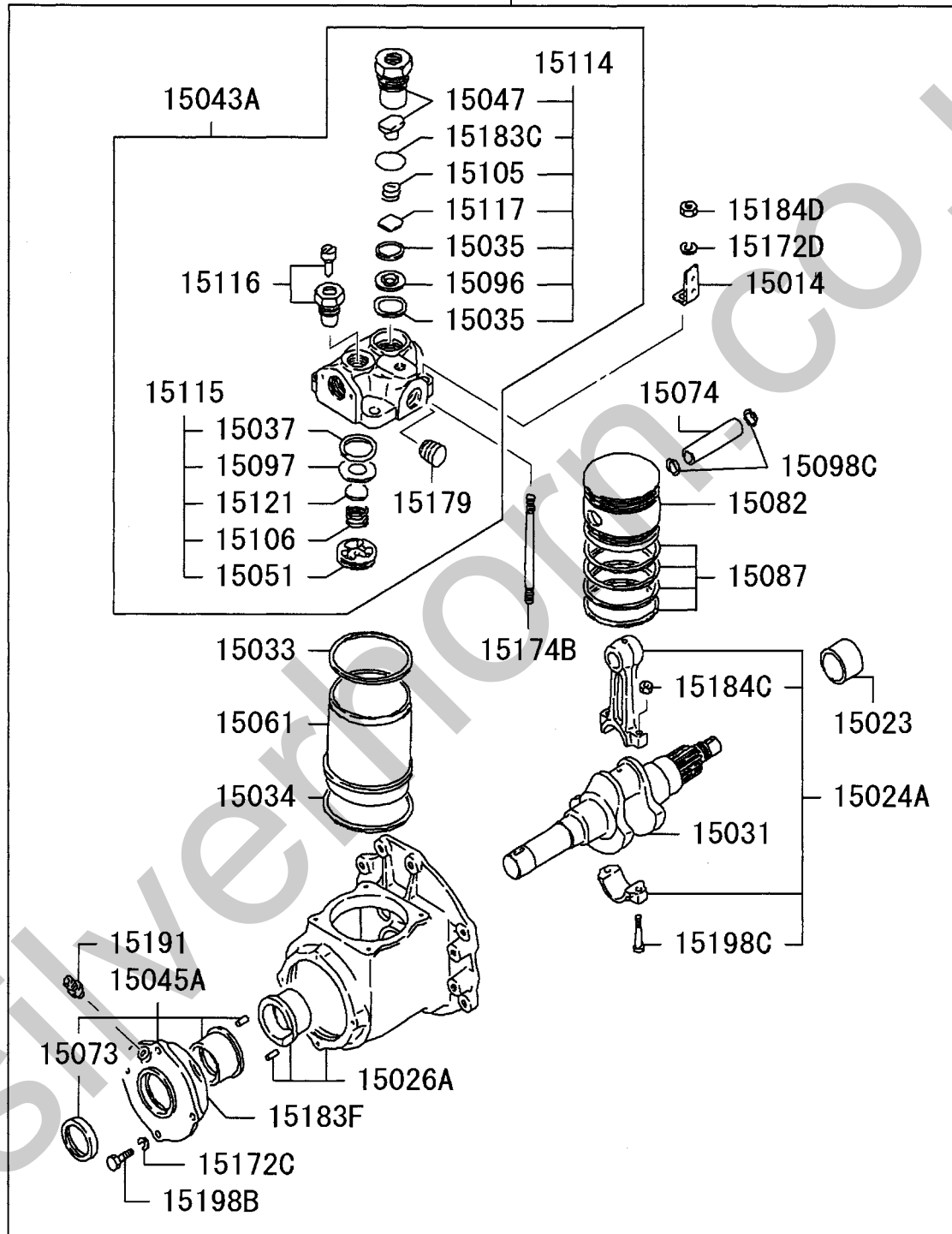

エアコンプレッサ
11 -340 AIR COMPRESSOR

01 6D240 CTJS07000

-40-

見出番号 REF.-NO.	部品番号 PART NO.	代 替 R / P 変 記 順 号 S C E N Q G	部品名称および記事・仕様記号 PART NAME & DESCRIPTION	型式・個数 MODEL & QTY					適用号機 APPLICABLE SERIAL NO.		管 区 M / R 新 規 V R D
				0	1				FROM@-	@UPTO	
15000A	ME150600 (ME355448)	3	AIR COMPRESSOR ASSY	1					0105-1	0408-3	
	ME355448		AIR COMPRESSOR ASSY	1					0409-1		
15014	ME713031		BRACKET,AIR COMPRESSOR HEAD PIPE	1					0105-1		
15023	ME713226		COLLAR,AIR COMPRESSOR	1					0105-1	0408-3	
	ME713266		COLLAR,AIR COMPRESSOR	1					0409-1		
15024A	ME737132		CONNECTING ROD ASSY,AIR COMPRESSOR	1					0105-1		
15026A	ME057119		CRANKCASE ASSY,AIR COMPRESSOR	1					0105-1		
15031	ME737139		CRANKSHAFT,AIR COMPRESSOR	1					0105-1		
15033	3097524500		GASKET,AIR COMPRESSOR CYLINDER HEAD	1					0105-1	0408-3	
	ME713014		GASKET,AIR COMPRESSOR CYLINDER HEAD	1					0409-1		
15034	ME713329		GASKET,AIR COMPRESSOR CYLINDER LINER	1					0105-1		
15035	3097522800		GASKET,AIR COMPRESSOR DELIVERY VALVE	2					0105-1	0408-3	
	ME713024		GASKET,AIR COMPRESSOR DELIVERY VALVE	2					0409-1		
15037	ME713020		GASKET,AIR COMPRESSOR SUCTION VALVE	1					0105-1		
15043A	ME713206		HEAD ASSY,AIR COMPRESSOR CYLINDER	1					0105-1		
15045A	ME737214		HOLDER ASSY,AIR COMPRESSOR BEARING	1					0105-1	0408-3	
	ME737042		HOLDER ASSY,AIR COMPRESSOR BEARING	1					0409-1		
15047	ME713224		HOLDER,AIR COMPRESSOR DELIVERY VALVE	1					0105-1		
15051	3097523100		HOLDER,AIR COMPRESSOR SUCTION VALVE	1					0105-1	0408-3	
	ME713016		HOLDER,AIR COMPRESSOR SUCTION VALVE	1					0409-1		
15054B	ME057332		HOSE,AIR COMPRESSOR SUCTION 20X220	1					0205-1		
15054C	3117503901		HOSE,AIR COMPRESSOR SUCTION 20X78	1					0205-1		
15061	3097522100		LINER,AIR COMPRESSOR CYLINDER	1					0105-1	0408-3	
	ME760103		LINER,AIR COMPRESSOR CYLINDER	1					0409-1		
15073	ME737204		OIL SEAL,AIR COMPRESSOR CRANKSHAFT,FR	1					0105-1	0408-3	
	ME713408	3	OIL SEAL,AIR COMPRESSOR CRANKSHAFT,FR	1					0409-1		
	(ME737118)										
15074	ME737202		PIN,AIR COMPRESSOR PISTON	1					0105-1		
15076	ME150237		PIPE,AIR COMPRESSOR WATER OUTLET	1					0105-1		
15078	ME157205		PIPE,AIR COMPRESSOR SUCTION	1					0105-1	0204-3	
	ME441099		PIPE,AIR COMPRESSOR SUCTION	1					0205-1		
15078B	ME441102		PIPE,AIR COMPRESSOR SUCTION	1					0205-1		
15081	ME150236		PIPE,AIR COMPRESSOR WATER INLET	1					0105-1		
15082	ME713361		PISTON,AIR COMPRESSOR CYLINDER	1					0105-1	0408-3	
	ME760102		PISTON,AIR COMPRESSOR CYLINDER	1					0409-1		
15087	ME713327	#	RING SET,AIR COMPRESSOR PISTON T03016	1					0105-1	0408-3	
	ME713466		RING SET,AIR COMPRESSOR PISTON	1					0409-1		
15095	ME713409		SLEEVE,AIR COMPRESSOR CRANKSHAFT	1					0409-1		
15096	3097522700		SEAT,AIR COMPRESSOR DELIVERY VALVE	1					0105-1	0408-3	
	ME713023		SEAT,AIR COMPRESSOR DELIVERY VALVE	1					0409-1		
15097	ME713019		SEAT,AIR COMPRESSOR SUCTION VALVE	1					0105-1		
15098C	ME713078		SNAP RING,AIR COMPRESSOR INR	2					0105-1		
15105	3097522500 (ME713021)	R	SPRING,AIR COMPRESSOR DELIVERY VALVE	1					0105-1	0408-3	
	ME713021		SPRING,AIR COMPRESSOR DELIVERY VALVE	1					0409-1		
15106	3097523200	R	SPRING,AIR COMPRESSOR SUCTION VALVE	1					0105-1	0408-3	

17 コンプレッサ
11 -340 AIR COMPRESSOR

01 6D240 CTJS07000

-41-

見出番号 REF.-NO.	部品番号 PART NO.	代 替 R / P 変 記 順 号 S C E N Q G	部品名称および記事・仕様記号 PART NAME & DESCRIPTION	型式・個数 MODEL & QTY				適用号機 APPLICABLE SERIAL NO.		管 区 M / R 新 規 V R D
				0	1			FROM@-	@UPTO	
15114	(ME713017)		SPRING,AIR COMPRESSOR SUCTION VALVE	1				0409-1		
	ME713017		VALVE KIT,AIR COMPRESSOR DELIVERY	1				0105-1	0408-3	
	3097502060		VALVE KIT,AIR COMPRESSOR DELIVERY	1				0409-1		
15115	ME713032		VALVE KIT,AIR COMPRESSOR SUCTION	1				0105-1	0408-3	
	3097502070		VALVE KIT,AIR COMPRESSOR SUCTION	1				0409-1		
15116	ME713033		VALVE KIT,AIR COMPRESSOR UNLOADER	1				0105-1		
15117	ME737130		VALVE,AIR COMPRESSOR DELIVERY	1				0105-1		
15121	ME713022		VALVE,AIR COMPRESSOR SUCTION	1				0105-1	0408-3	
	3097523300		VALVE,AIR COMPRESSOR SUCTION	1				0409-1		
15172B	ME713018		WASHER,AIR COMPRESSOR INR	2				0409-1		
15172C	ME713009		WASHER,AIR COMPRESSOR INR	4				0105-1	0408-3	
15172D	ME713076		WASHER,AIR COMPRESSOR INR	4				0105-1	0408-3	
	F251510000		SPRING,10							
	ME713081		WASHER,AIR COMPRESSOR INR	4				0409-1		
			SPRING,10							
15174B	ME713208		STUD,AIR COMPRESSOR	4				0105-1		
15176F	3097504400		STAY,AIR COMPRESSOR	1				0105-1	0204-3	
15179	ME713385		PLUG,AIR COMPRESSOR INR	1				0105-1		
15183	MH035606		O-RING,AIR COMPRESSOR	1				0105-1	0107-3	
			D=154							
	ME093522		O-RING,AIR COMPRESSOR	1				0108-1		
			D=153.4							
15183C	3097522900		O-RING,AIR COMPRESSOR	1				0105-1	0408-3	
	ME713025		O-RING,AIR COMPRESSOR	1				0409-1		
15183F	ME713337		O-RING,AIR COMPRESSOR	1				0105-1		
15184C	ME737201		NUT,AIR COMPRESSOR INR	2				0105-1	0408-3	
	ME713008		NUT,AIR COMPRESSOR INR	2				0409-1		
15184D	ME713082		NUT,AIR COMPRESSOR INR	4				0105-1		
			10							
15186	MF476220		KEY,AIR COMPRESSOR	1				0105-1		
			WOODRUFF,6X25							
15189B	F420214000		GASKET,AIR COMPRESSOR	3				0105-1		
			D=14							
15189C	F420216000		GASKET,AIR COMPRESSOR	2				0105-1		
			D=16							
15189D	F420227000		GASKET,AIR COMPRESSOR	1				0105-1		
			D=27							
15189E	MH035190		GASKET,AIR COMPRESSOR	2				0105-1		
			18							
15189F	MH035192		GASKET,AIR COMPRESSOR	2				0105-1		
			24							
15191	ME713196		JOINT,AIR COMPRESSOR INR	1				0105-1		
15192B	MH038913		JOINT,AIR COMPRESSOR	1				0105-1	0204-3	
15192BC	MH037397		JOINT,AIR COMPRESSOR	1				0205-1		
15192D	MH037507		JOINT,AIR COMPRESSOR	1				0105-1		
15192E	MH037453		JOINT,AIR COMPRESSOR	1				0105-1		
15194B	MH020290		CLIP,AIR COMPRESSOR	1				0105-1	0204-3	
			20							
15194C	MH020558		CLIP,AIR COMPRESSOR	1				0105-1	0204-3	

11 -340 AIR COMPRESSOR

エアコンプレッサ

01 6D240 CTJS07000

-42-

見出番号 REF.-NO.	部品番号 PART NO.	代 替 R / P 変 記 順 号 S C E N Q G	部品名称および記事・仕様記号 PART NAME & DESCRIPTION	型式・個数 MODEL & QTY					適用号機 APPLICABLE SERIAL NO.		管 区 M / R 新 規 V / R D
				0	1				FROM@-	@UPTO	
15195B	MS660170		D=20 CLAMP,AIR COMPRESSOR	2					0205-1		
15195C	MS660170		D=26 CLAMP,AIR COMPRESSOR	2					0205-1		
15197B	MF650106		EYEBOLT,AIR COMPRESSOR 18X28	1					0105-1		
15197D	3097506600		EYEBOLT,AIR COMPRESSOR 24X36	1					0105-1		
15197E	F461016000		EYEBOLT,AIR COMPRESSOR 16X29	1					0105-1		
15197F	MH037087		EYEBOLT,AIR COMPRESSOR 14X26	1					0105-1		
15198B	ME713077		BOLT,AIR COMPRESSOR INR 8X22	4					0105-1	0408-3	
	ME713384		BOLT,AIR COMPRESSOR INR 8X22	4					0409-1		
15198C	ME713093		BOLT,AIR COMPRESSOR INR	2					0105-1		
15199B	MH000724		BOLT,AIR COMPRESSOR FLANGE,10X85	5					0105-1	0202-3	
	MS146023		BOLT,AIR COMPRESSOR FLANGE,10X85	5					0203-1		
15199C	MH000713	#	BOLT,AIR COMPRESSOR FLANGE,10X20 T02406A	1					0105-1	0211-1	
	MS146003		BOLT,AIR COMPRESSOR FLANGE,10X18	1					0211-2		
15199D	MH000706		BOLT,AIR COMPRESSOR FLANGE,10X16	1					0105-1	0204-3	
15199DC	MH000999		BOLT,AIR COMPRESSOR FLANGE,6X12	1					0105-1	0204-3	
15199DE	MH000922		BOLT,AIR COMPRESSOR FLANGE,12X16	1					0105-1		
15199EB	MF140023		BOLT,AIR COMPRESSOR FLANGE,8X16	1					0205-1		

SIDE COVER

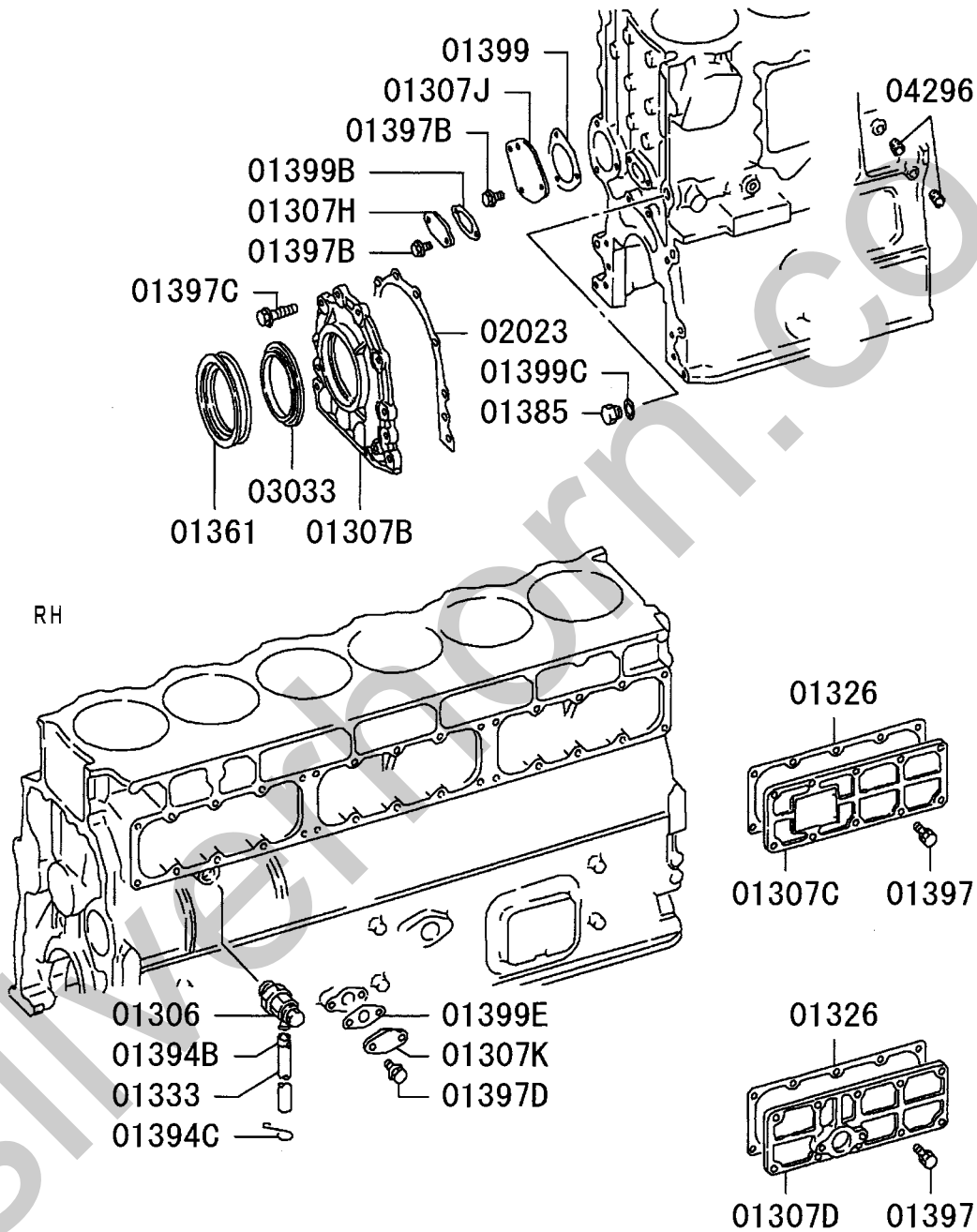

ENGINE HANGER

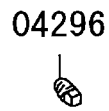
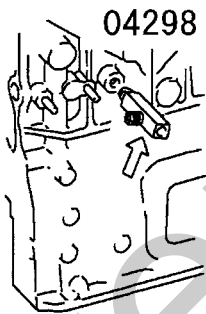
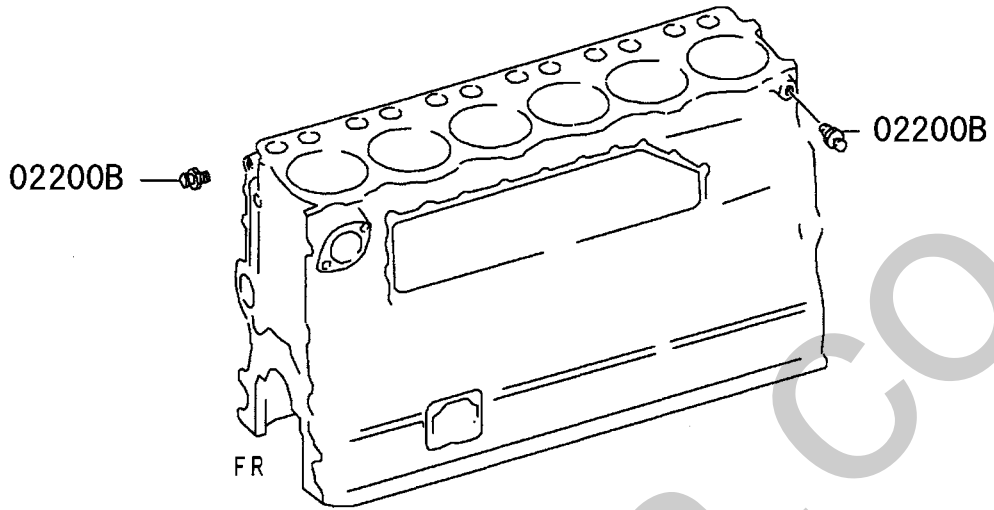

11 -410 ATTACHING PARTS

アタッチング パーツ

01 6D240 CTJS07000

-46-

見出番号 REF.-NO.	部品番号 PART NO.	代 替 R / P 記 順 号 S C E N Q G	部品名称および記事・仕様記号 PART NAME & DESCRIPTION	型式・個数 MODEL & QTY					適用号機 APPLICABLE SERIAL NO.		管 区 M / R	新 規 V R D
				0	1				FROM@-	@UPTO		
01306	ME133039		COCK,CYLINDER BLOCK WATER DRAIN	1					0105-1			
01307B	ME120432		COVER,CYLINDER BLOCK	1					0105-1			
01307C	ME051003	#	COVER,CYLINDER BLOCK T03092	1					0105-1			
01307D	ME051344		COVER,CYLINDER BLOCK	2					0105-1			
01307H	3090702600		COVER,CYLINDER BLOCK	1					0105-1			
01307J	3090703500		COVER,CYLINDER BLOCK	1					0105-1			
01307K	ME051241		COVER,CYLINDER BLOCK	1					0105-1			
01326	ME152473		GASKET,CYLINDER BLOCK SIDE COVER	3					0105-1			
01333	3090705800		HOSE,CYLINDER BLOCK WATER DRAIN 12X380	1					0105-1			
01361	ME060124		OIL SEAL,CYLINDER BLOCK FR COVER	1					0105-1			
01385	MH037723		PLUG,CYLINDER BLOCK SCREW,D=27	1					0105-1			
01394B	ME153301		CLAMP,CYLINDER BLOCK D=16.5	1					0105-1			
01394C	3000715301		CLAMP,CYLINDER BLOCK D=18,11	1					0105-1			
01397	MF300845		BOLT,CYLINDER BLOCK WASHER ASSEMBLED,10X30	2					0105-1			
	MF303365		BOLT,CYLINDER BLOCK WASHER ASSEMBLED,10X30	28					0105-1			
01397B	MH000713	#	BOLT,CYLINDER BLOCK FLANGE,10X20 T02406A	5					0105-1	0306-2		
	MS146004		BOLT,CYLINDER BLOCK FLANGE,10X20	5					0306-3			
01397C	MS146053		BOLT,CYLINDER BLOCK FLANGE,12X30	8					0105-1			
01397D	MS146004		BOLT,CYLINDER BLOCK FLANGE,10X20	2					0105-1			
01399	ME150056		GASKET,CYLINDER BLOCK	1					0105-1			
01399B	ME150057		GASKET,CYLINDER BLOCK	1					0105-1			
01399C	F420227000		GASKET,CYLINDER BLOCK D=27	1					0105-1			
01399E	ME054744		GASKET,CYLINDER BLOCK D=20	1					0105-1			
02023	ME150058		GASKET,CRANKSHAFT FR OIL SEAL CASE	1					0105-1			
02200B	ME040252		ENGINE HANGER	2					0105-1			
03033	ME060125		OIL SLINGER,CRANKSHAFT,FR	1					0105-1			
04296	MS666220		PLUG,ENG OIL PRESSURE GAUGE TAPER,1/8	4					0105-1	0112-3		
	MH037788		PLUG,ENG OIL PRESSURE GAUGE TAPER,1/8	2					0201-1			
	MS666220		PLUG,ENG OIL PRESSURE GAUGE TAPER,1/8	2					0201-1			
04298	MH039564		JOINT,ENG OIL PRESSURE GAUGE	1					0105-1			

オイルポンプ & ストレーナ
12 -110 OIL PUMP & STRAINER

-48-

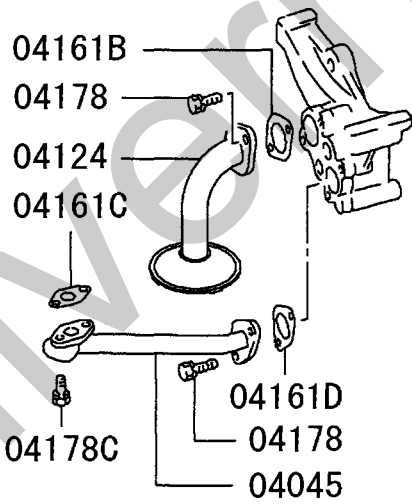
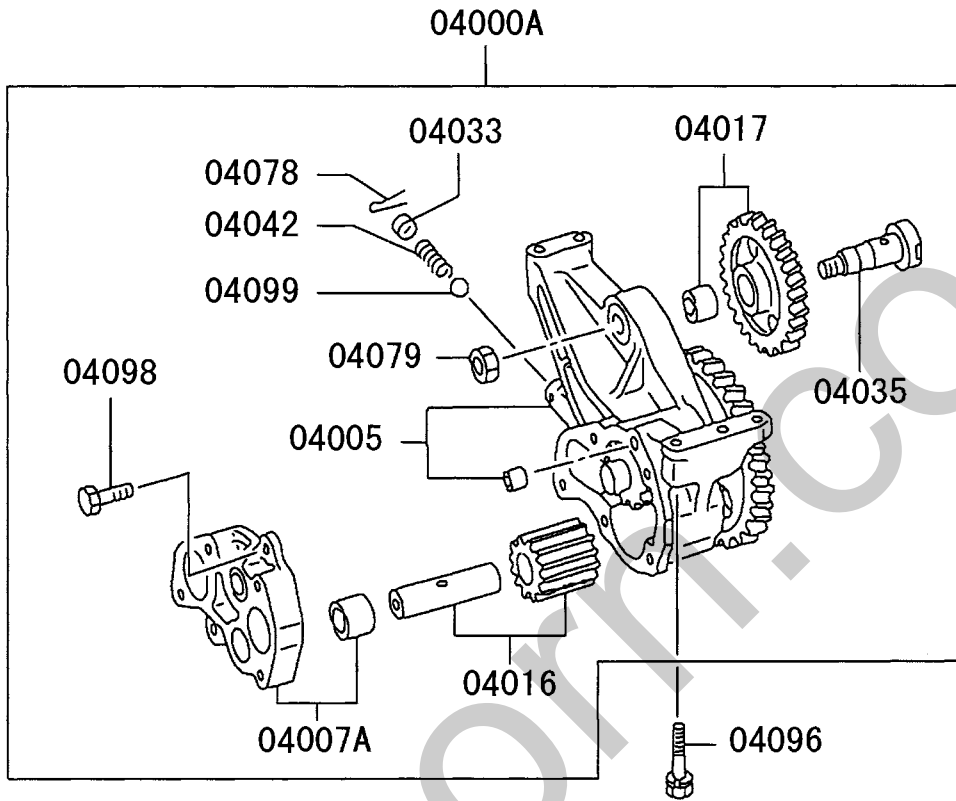

213T01

オイルポンプ & ストレーナ
12 -110 OIL PUMP & STRAINER

01 6D240 CTJS07000

-49-

見出番号 REF.-NO.	部品番号 PART NO.	代 替 R / P 変 更 順 号 S C E N E Q G	部品名称および記事・仕様記号 PART NAME & DESCRIPTION	型式・個数 MODEL & QTY					適用号機 APPLICABLE	管 区 M / R 新 規 V R D
				0	1				SERIAL NO. FROM@- @UPTO	
04000A	ME150601		OIL PUMP ASSY,ENG	1					0105-1	
04005	ME151877		GEAR & CASE KIT,ENG OIL PUMP	1					0105-1	
04007A	ME350565		COVER ASSY,ENG OIL PUMP	1					0105-1	
04016	ME160708		GEAR,ENG OIL PUMP DRIVEN	1					0105-1	
04017	ME150639		GEAR,ENG OIL PUMP IDLER	1					0105-1	
04033	ME160715		SEAT,ENG OIL PUMP RELIEF VALVE	1					0105-1	
04035	ME162632		SHAFT,ENG OIL PUMP IDLER GEAR	1					0105-1	
04042	ME160705		SPRING,ENG OIL PUMP RELIEF VALVE	1					0105-1	
04045	ME121284		TUBE,ENG OIL PUMP OUTLET	1					0105-1	
04078	MF472086		PIN,ENG OIL PUMP INR SPLIT,4X35	1					0105-1	
04079	MH004069		NUT,ENG OIL PUMP INR FLANGE, 12	1					0105-1	
04096	MF300850		BOLT,ENG OIL PUMP WASHER ASSEMBLED,10X45	3					0105-1	
04098	MH000715		BOLT,ENG OIL PUMP INR FLANGE,10X35	2					0105-1	
04099	MF540021		BALL,ENG OIL PUMP INR 21/32	1					0105-1	
04124	ME150532		STRAINER,ENG OIL PAN	1					0105-1	
04161B	ME150541		GASKET,OIL STRAINER D=41	1					0105-1	0312-3
	ME351447		GASKET,OIL STRAINER D=41	1					0401-1	
04161C	ME151866	3	GASKET,OIL STRAINER D=22	1					0105-1	0203-3
	(ME351483) ME351483		GASKET,OIL STRAINER D=25	1					0204-1	
04161D	ME151865		GASKET,OIL STRAINER D=32	1					0105-1	
04178	MF300853		BOLT,OIL STRAINER WASHER ASSEMBLED,10X60	4					0105-1	
04178C	MF300843		BOLT,OIL STRAINER WASHER ASSEMBLED,10X25	2					0105-1	

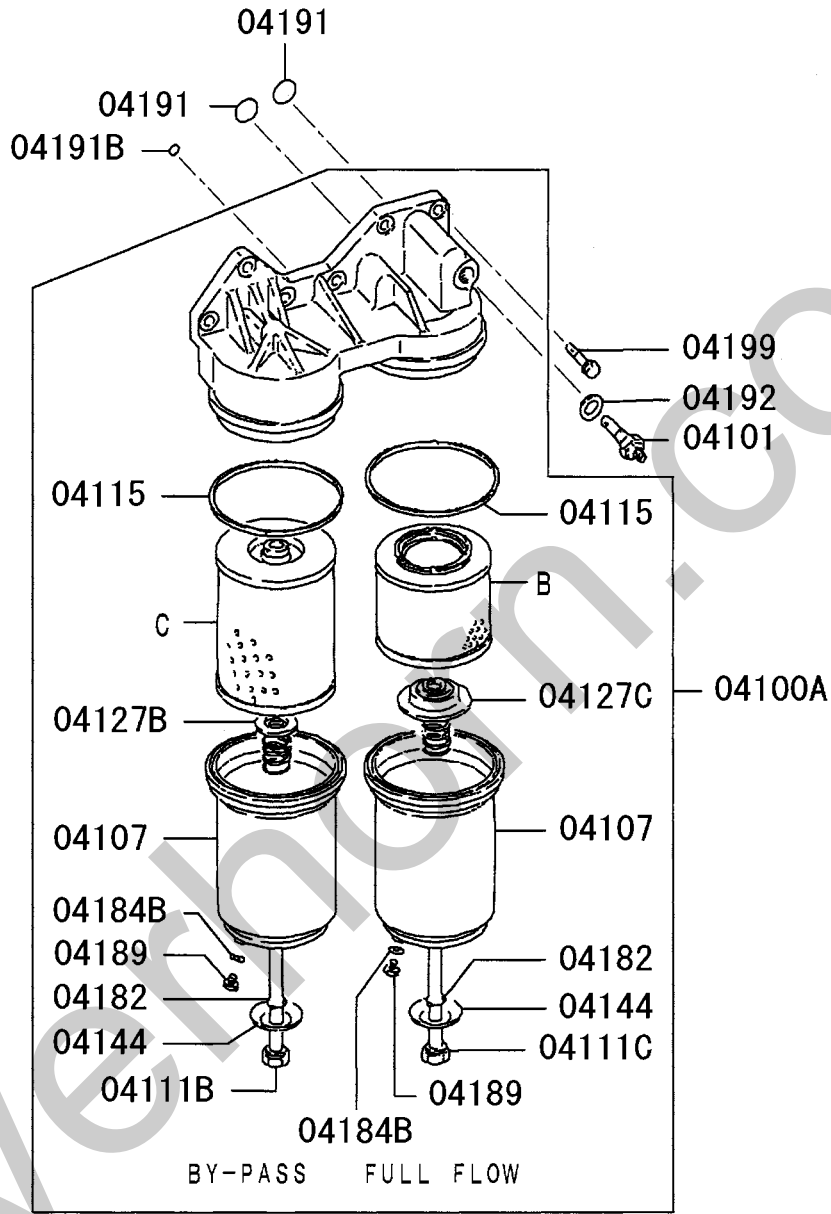

04180

04130	04140
PNC C, 04115, 04182, 04184B	PNC B, 04115, 04182, 04184B

C: ELEMENT, BY-PASS

B: ELEMENT, FULL FLOW

オイルフィルタ
12 -120 OIL FILTER

01 6D240 CTJS07000

-51-

見出番号 REF.-NO.	部品番号 PART NO.	代 替 R / P 記 順 号 S C E N Q G	部品名称および記事・仕様記号 PART NAME & DESCRIPTION	型式・個数 MODEL & QTY					適用号機 APPLICABLE SERIAL NO.	管 区 M / R 新 規 V R D	
				0	1						FROM@- @UPTO
04100A	ME180513		OIL FILTER & HEAD ASSY	1						0105-1	
04101	ME054661		SWITCH,OIL FILTER BY-PASS	1						0105-1	
04107	3124051203		CASE,OIL FILTER	2						0105-1	
04111B	ME164716		CENTER BOLT,OIL FILTER 16X226	1						0105-1	
04111C	3124050500		CENTER BOLT,OIL FILTER 16X165	1						0105-1	
04115	ME121800		GASKET,OIL FILTER CASE	2						0105-1	
04127B	ME054156		RETAINER,OIL FILTER ELEMENT	1						0105-1	
04127C	ME054082		RETAINER,OIL FILTER ELEMENT	1						0105-1	
04130	ME165370		ELEMENT KIT,BY-PASS OIL FILTER	1						0105-1	
04140	ME121788		ELEMENT KIT,OIL FILTER	1						0105-1	
04144	3124053900		WASHER,OIL FILTER PLAIN,D=16.5	2						0105-1	
04180	ME180514		ELEMENT KIT,MAIN & BY-PASS OIL FILTER	1						0105-1	
04182	MH035025		O-RING,OIL FILTER INR D=16	2						0105-1	
04184B	F420210000		GASKET,OIL FILTER INR D=10	2						0105-1	
04189	3124050900		PLUG,OIL FILTER	2						0105-1	
04191	3113902201		O-RING,OIL FILTER D=23.6	2						0105-1	
04191B	3124054500		O-RING,OIL FILTER D=10.8	1						0105-1	
04192	F420220000		GASKET,OIL FILTER D=20	1						0105-1	
04199	MS146010		BOLT,OIL FILTER FLANGE,10X35	7						0105-1	

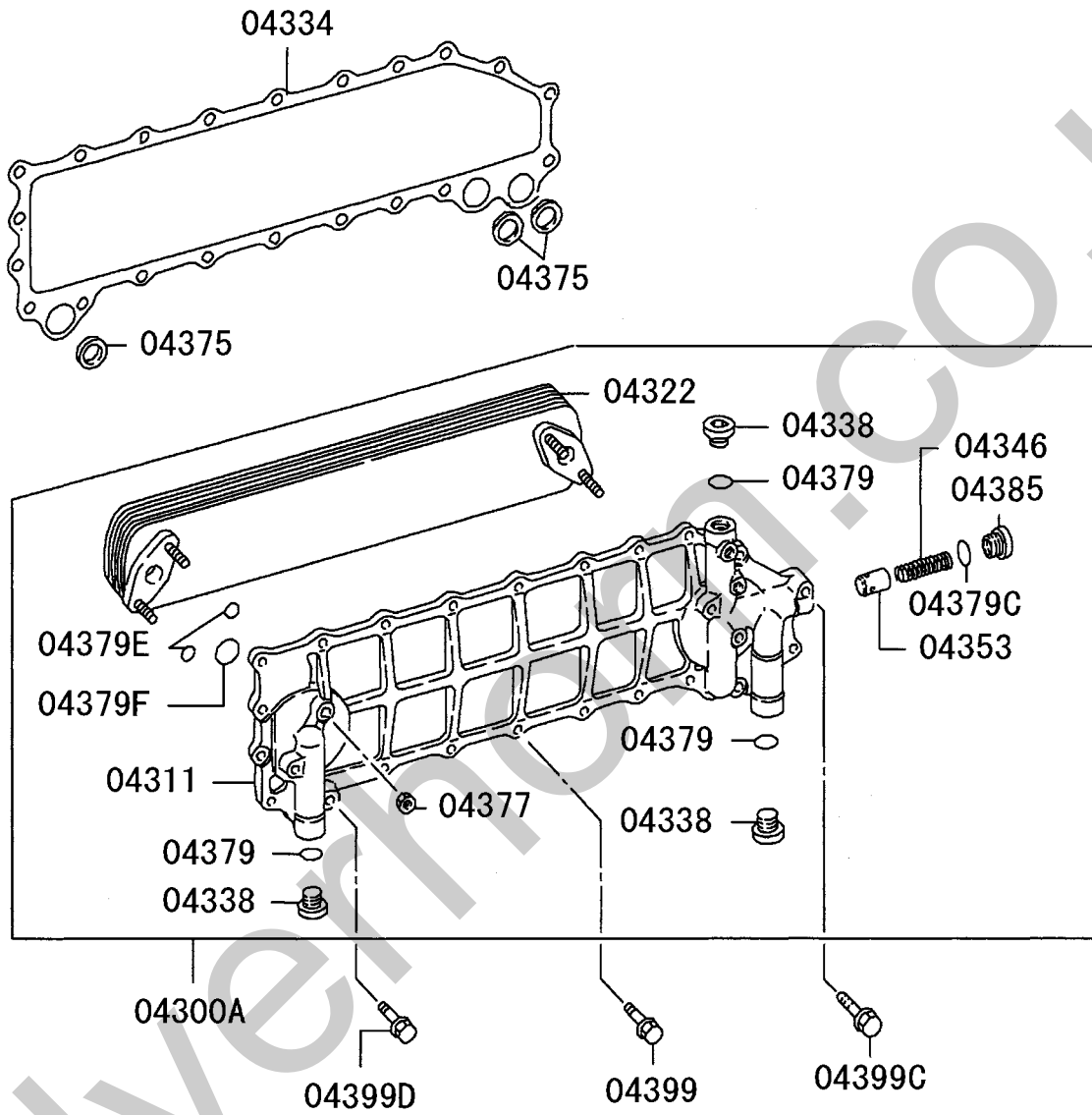

オイルクーラ
12 -130 OIL COOLER

01 6D240 CTJS07000

-53-

見出番号 REF.-NO.	部品番号 PART NO.	代 替 R / P	委 記 順 号 S C E N Q G	部品名称および記事・仕様記号 PART NAME & DESCRIPTION	型式・個数 MODEL & QTY					適用号機 APPLICABLE SERIAL NO.	管 区 M / R	新 規 V R D	
					0	1							FROM@-@UPTO
04300A	ME150453			OIL COOLER ASSY,ENG	1						0105-1		
04311	ME150441			COVER,ENG OIL COOLER	1						0105-1		
04322	ME153172			ELEMENT,ENG OIL COOLER	1						0105-1		
04334	ME150682			GASKET,ENG OIL COOLER COVER	1						0105-1		
04338	ME064526	#		PLUG,ENG OIL COOLER SCREW,D=27 T03114	3						0105-1		
04346	ME153173			SPRING,ENG OIL COOLER BY-PASS VALVE	1						0105-1		
04353	ME084527			VALVE,ENG OIL COOLER BY-PASS	1						0105-1		
04375	3093900300			O-RING,ENG OIL COOLER D=25	3						0105-1		
04377	ME150442			NUT,ENG OIL COOLER INR 10	4						0105-1		
04379	MH035093			O-RING,ENG OIL COOLER INR D=25	3						0105-1		
04379C	MH035044			O-RING,ENG OIL COOLER INR D=18	1						0105-1		
04379E	MH035092			O-RING,ENG OIL COOLER INR D=14	4						0105-1		
04379F	MH035626			O-RING,ENG OIL COOLER INR D=30	2						0105-1		
04385	ME014717			PLUG,ENG OIL COOLER INR D=20	1						0105-1		
04399	MS146006			BOLT,ENG OIL COOLER FLANGE,10X25	19						0105-1		
	MS146008			BOLT,ENG OIL COOLER FLANGE,10X30	1						0105-1		
04399C	MS146016			BOLT,ENG OIL COOLER FLANGE,10X50	1						0105-1		
04399D	MS146014			BOLT,ENG OIL COOLER FLANGE,10X45	1						0105-1		

オイルライン
12 -140 OIL LINE

-54-

FOR INJ PUMP & 1CYL A/COMPR

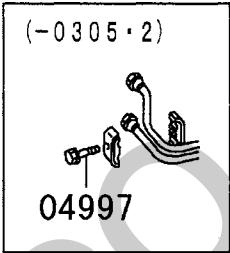
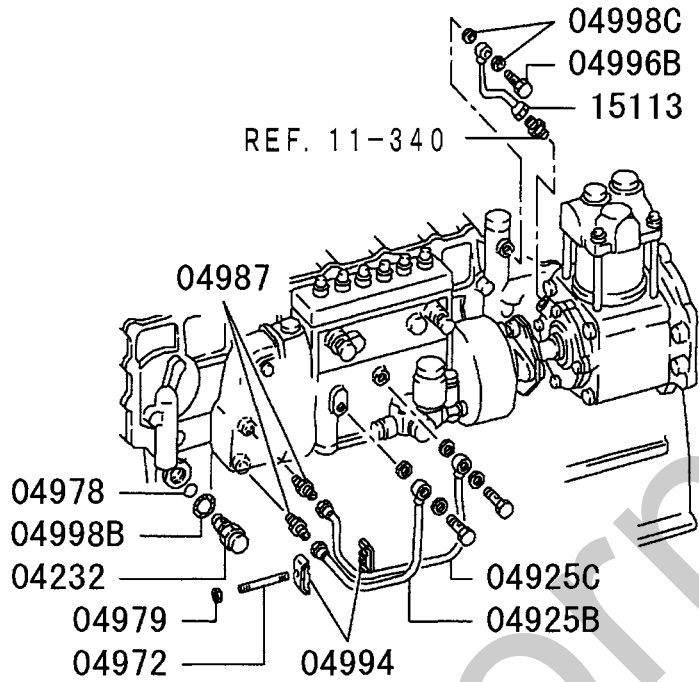

Silverhobby.com.uk

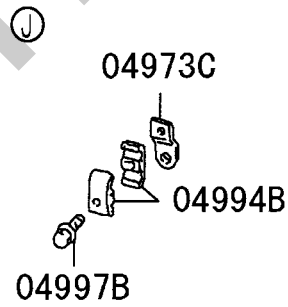
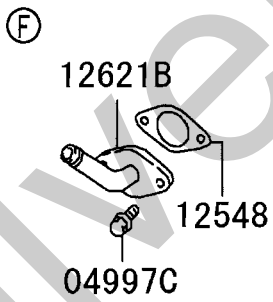
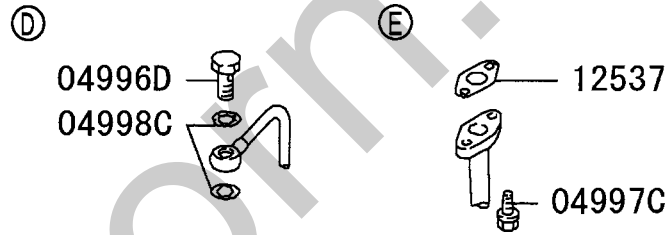
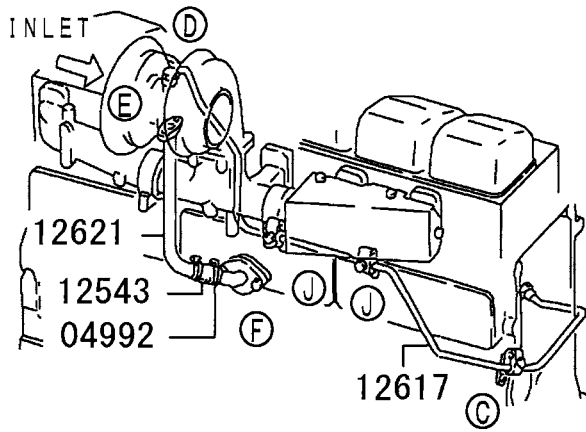

オイルライン
12 -140 OIL LINE

-56-

01 6D240 CTJS07000

見出番号 REF.-NO.	部品番号 PART NO.	代 替 R / P 記 順 号 S C E N Q G	部品名称および記事・仕様記号 PART NAME & DESCRIPTION	型式・個数 MODEL & QTY					適用号機 APPLICABLE SERIAL NO.		管 区 M / R	新 規 V R D
				0	1				FROM@-	@UPTO		
04232	ME074455		VALVE,ENG OIL PRESSURE REGULATING	1					0105-1			
04925B	3093602300		TUBE,ENG OIL LINE	1					0105-1			
04925C	ME158066		TUBE,ENG OIL LINE	1					0105-1			
04972	MF406251		STUD,ENG OIL LINE 6X35	1					0305-3			
04973C	ME930001		STAY,ENG OIL LINE	2					0105-1			
04978	MH035129		O-RING,ENG OIL LINE D=17.4	1					0105-1			
04979	MF434103		NUT,ENG OIL LINE FLANGE,6	1					0305-3			
04987	MH038906		JOINT,ENG OIL LINE	2					0105-1			
04992	MH021295		CLIP,ENG OIL LINE D=31	2					0105-1			
04994	MH021233	#	CLAMP,ENG OIL LINE D=6X2 T05051	2					0105-1			
04994B	MH021260		CLAMP,ENG OIL LINE D=9X2	6					0105-1			
04996B	MH037279		EYEBOLT,ENG OIL LINE 10X20	1					0105-1			
04996D	MH037716		EYEBOLT,ENG OIL LINE 10X26	1					0105-1			
04997	MF140011		BOLT,ENG OIL LINE FLANGE,6X30	1					0105-1	0305-2		
04997B	MF140213		BOLT,ENG OIL LINE FLANGE,6X35	3					0105-1			
04997C	MH000713	#	BOLT,ENG OIL LINE FLANGE,10X20 T02406A	4					0105-1	0306-2		
	MS146004		BOLT,ENG OIL LINE FLANGE,10X20	4					0306-3			
04998B	F420227000		GASKET,ENG OIL LINE D=27	1					0105-1			
04998C	F420210000		GASKET,ENG OIL LINE D=10	4					0105-1			
12537	ME054744		GASKET,T/C OIL RETURN TUBE	1					0105-1			
12543	ME054279		HOSE,T/C OIL RETURN TUBE RUBBER,21X85	1					0105-1			
12548	ME157194		GASKET,T/C OIL RETURN PIPE TO CYLINDER B	1					0105-1			
12617	ME159062		TUBE,T/C OIL FEED	1					0105-1			
12621	ME157230		TUBE,T/C OIL RETURN	1					0105-1			
12621B	ME058983		TUBE,T/C OIL RETURN	1					0105-1			
15113	3093613500		TUBE,AIR COMPRESSOR OIL FEED	1					0105-1			

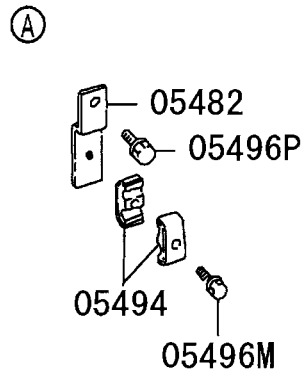
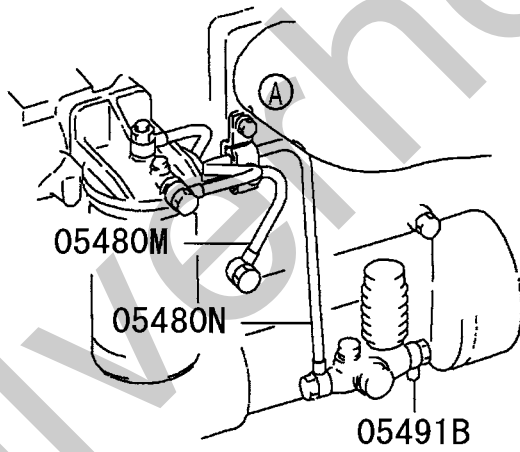
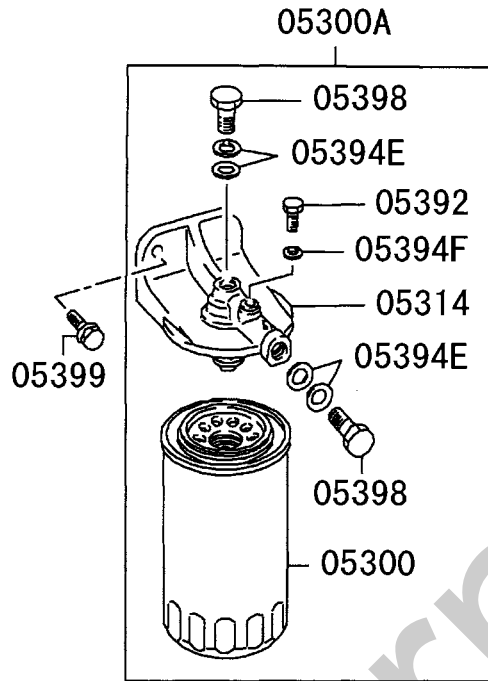

13 -030 FUEL FILTER & HOSE

フューエルフィルタ & ホース

01 6D240 CTJS07000

-59-

見出番号 REF.-NO.	部品番号 PART NO.	代 替 順 号 / P	記 号 S C E N Q G	部品名称および記事・仕様記号 PART NAME & DESCRIPTION	型式・個数 MODEL & QTY				適用号機 APPLICABLE SERIAL NO.		管 区 M / R	新 規 V R D
					0	1			FROM@-	@UPTO		
05300	ME056670			FUEL FILTER	1					0105-1		
05300A	ME090010 (ME090012)	3		FUEL FILTER ASSY	1					0105-1		
05314	ME056279			HEAD,FUEL FILTER	1					0105-1		
05392	ME016894			PLUG,FUEL FILTER SCREW,8X9	1					0105-1		
05394E	MH035069			GASKET,FUEL FILTER D=14	4					0105-1		
05394F	MH035067			GASKET,FUEL FILTER D=8	1					0105-1		
05398	MH037087			EYEBOLT,FUEL FILTER 14X26	2					0105-1		
05399	MH000714			BOLT,FUEL FILTER FLANGE,10X25	2					0105-1	0204-1	
	MS146006			BOLT,FUEL FILTER FLANGE,10X25	2					0204-2		
05480M	ME158184			TUBE,FUEL LINE 10	1					0105-1		
05480N	ME158183			TUBE,FUEL LINE 10	1					0105-1		
05482	ME930211			STAY,FUEL LINE	1					0105-1		
05491B	MH037116			JOINT,FUEL LINE	1					0105-1		
05494	MH021218			CLAMP,FUEL LINE D=9X2	2					0105-1		
05496M	MF140213			BOLT,FUEL LINE FLANGE,6X35	1					0105-1		
05496P	MH000706			BOLT,FUEL LINE FLANGE,10X16	1					0105-1	0206-2	
	MS146002			BOLT,FUEL LINE FLANGE,10X16	1					0206-3		

13 -110 FUEL INJECTION PUMP GENERAL

燃料インジェクションポンプ 一般

-60-

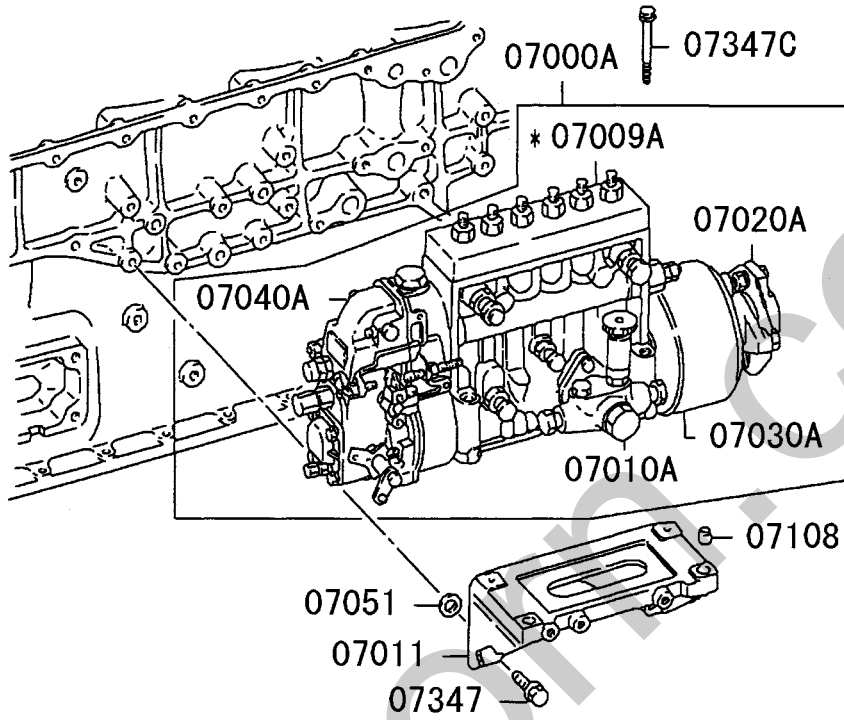

13 -110 FUEL INJECTION PUMP GENERAL

01 6D240 CTJS07000

-61-

見出番号 REF.-NO.	部品番号 PART NO.	代 替 R / P	変 記 順 号 S C / E N / Q G	部品名称および記事・仕様記号 PART NAME & DESCRIPTION	型式・個数 MODEL & QTY				適用号機 APPLICABLE SERIAL NO.		管 区 M / R	新 規 V / R / D
					0	1			FROM @-	@UPTO		
07000A	1066762602			PUMP ASSY,FUEL INJECTION ZEXEL	1					0105-1		
07009A	*			BODY ASSY,INJECTION PUMP NS (ME740839)	1					0105-1	0111-1	
	*			BODY ASSY,INJECTION PUMP NS (ME755681)	1					0111-2		
07010A	1052071200 (1052106070)	3		PUMP ASSY,INJECTION PUMP FUEL FEED	1					0105-1		
07011	ME056381			BRACKET,INJECTION PUMP	1					0105-1		
07020A	1056630550			COUPLING ASSY,INJECTION PUMP	1					0105-1		
07030A	1056812790			TIMER ASSY,INJECTION PUMP	1					0105-1		
07040A	1054078050			GOVERNOR ASSY,INJECTION PUMP RSV	1					0105-1	0111-1	
	1054078110			GOVERNOR ASSY,INJECTION PUMP RSV	1					0111-2		
07051	3016101200			SHIM,INJECTION PUMP BRACKET T=0.1	AR					0105-1		
	3116101800			SHIM,INJECTION PUMP BRACKET T=0.2	AR					0404-1		
07108	MS471107			BUSHING,INJECTION PUMP BODY 10X9	2					0105-1		
07347	MS146310			BOLT,INJECTION PUMP FLANGE,10X35	4					0105-1		
07347C	MH000724			BOLT,INJECTION PUMP FLANGE,10X85	4					0105-1	0106-3	
	MS146023			BOLT,INJECTION PUMP FLANGE,10X85	4					0107-1		

インジェクションポンプ
13-120 INJECTION PUMP

-62-

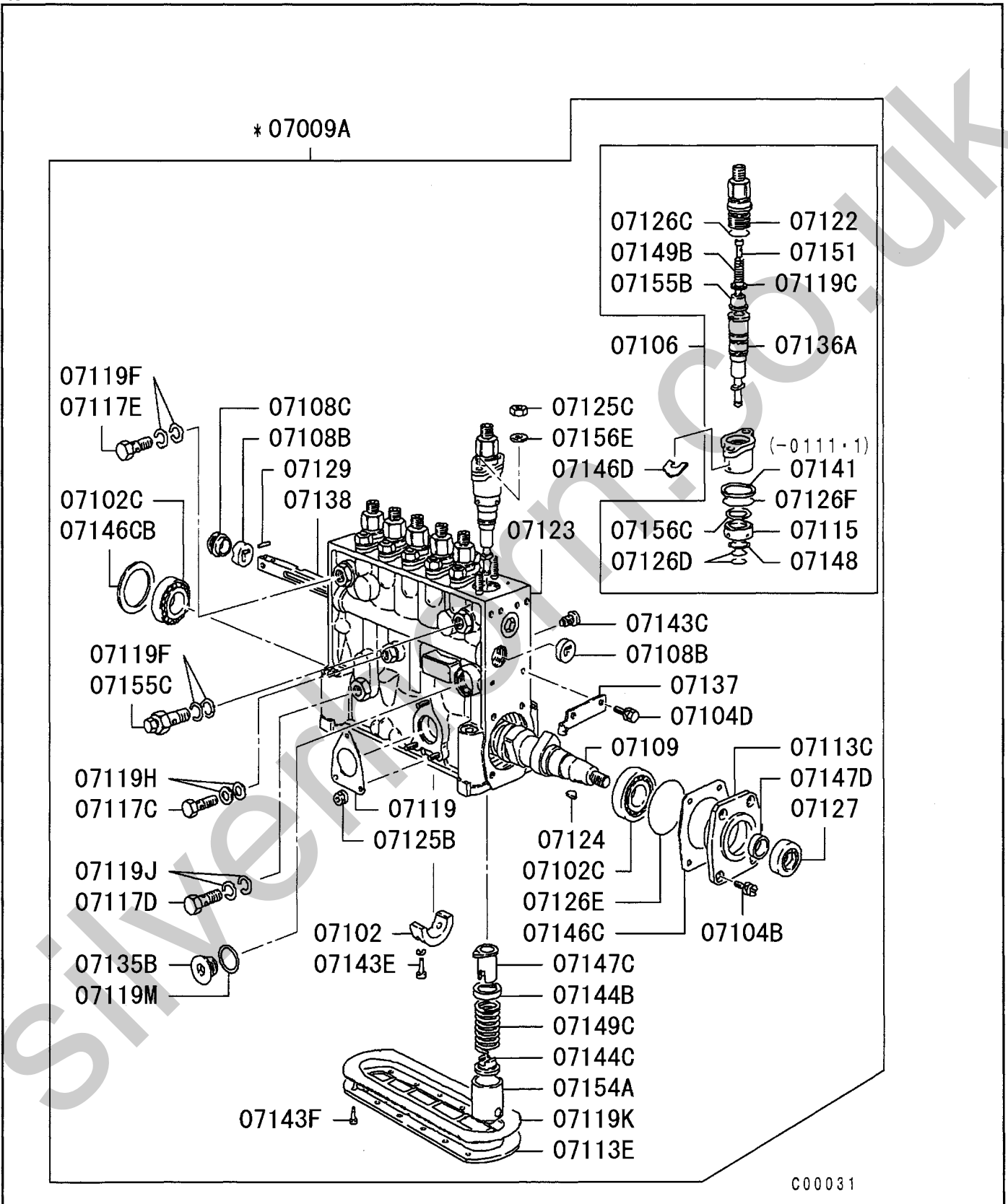

インジェクションポンプ
13-120 INJECTION PUMP

01 6D240 CTJS07000

-63-

見出番号 REF.-NO.	部品番号 PART NO.	代 替 R / P 記 順 号 S C E N Q G	部品名称および記事・仕様記号 PART NAME & DESCRIPTION	型式・個数 MODEL & QTY				適用号機 APPLICABLE SERIAL NO.		管 区 M / R 新 規 V R D
				0	1			FROM@-	@UPTO	
07009A	*		BODY ASSY,INJECTION PUMP NS (ME740839)	1				0105-1	0111-1	
	*		BODY ASSY,INJECTION PUMP NS (ME755681)	1				0111-2		
07102	1343060100		BEARING,INJECTION PUMP BODY	1				0105-1		
07102C	0166502230		BEARING,INJECTION PUMP BODY	2				0105-1		
07104B	0290106810		BOLT,INJECTION PUMP BODY	4				0105-1		
07104D	0200061240		BOLT,INJECTION PUMP BODY	2				0105-1		
07106	1341652220		BLOCK,INJECTION PUMP BODY	6				0105-1	0111-1	
	1341666920		BLOCK,INJECTION PUMP BODY	6				0111-2		V
07108B	1340010000		BUSHING,INJECTION PUMP BODY	2				0105-1		
07108C	1342220000		BUSHING,INJECTION PUMP BODY	1				0105-1		
07109	1343712800		CAMSHAFT,INJECTION PUMP BODY	1				0105-1		
07113C	1343161700		COVER,INJECTION PUMP BODY	1				0105-1		
07113E	1340430800		COVER,INJECTION PUMP BODY	1				0105-1		
07115	1341350200 (1341350400)	3	DEFLECTOR,INJECTION PUMP BODY	6				0105-1	0111-1	
	1341350400		DEFLECTOR,INJECTION PUMP BODY	6				0111-2		V
07117C	0297310180		EYEBOLT,INJECTION PUMP BODY	1				0105-1		
07117D	0297314680		EYEBOLT,INJECTION PUMP BODY	1				0105-1		
07117E	0297314570		EYEBOLT,INJECTION PUMP BODY	1				0105-1		
07119	1310410800		GASKET,INJECTION PUMP BODY	1				0105-1		
07119C	1341150100		GASKET,INJECTION PUMP BODY	6				0105-1		
07119F	0293414130		GASKET,INJECTION PUMP BODY	4				0105-1		
07119H	0265101340		GASKET,INJECTION PUMP BODY	2				0105-1		
07119J	0265141840		GASKET,INJECTION PUMP BODY	2				0105-1		
07119K	1340421400		GASKET,INJECTION PUMP BODY	1				0105-1		
07119M	0265242940		GASKET,INJECTION PUMP BODY	1				0105-1		
07122	1341162400		HOLDER,INJECTION PUMP BODY	6				0105-1		
07123	1340630920		HOUSING,INJECTION PUMP BODY	1				0105-1		
07124	0258051910		KEY,INJECTION PUMP BODY	1				0105-1		
07125B	1392060400		NUT,INJECTION PUMP BODY	3				0105-1		
07125C	0130210040		NUT,INJECTION PUMP BODY 10X8	12				0105-1		
07126C	1397220400		O-RING,INJECTION PUMP BODY	6				0105-1		
07126D	1397150400		O-RING,INJECTION PUMP BODY	12				0105-1		
07126E	0296355010		O-RING,INJECTION PUMP BODY	1				0105-1		
07126F	1397290400		O-RING,INJECTION PUMP BODY	6				0105-1		
07127	1396250000		OIL SEAL,INJECTION PUMP BODY	1				0105-1		
07129	0240302030		PIN,INJECTION PUMP BODY	1				0105-1		
07135B	1340450100		PLUG,INJECTION PUMP BODY	1				0105-1		
07136A	1341536620		PLUNGER ASSY,INJECTION PUMP BODY	6				0105-1	0111-1	
	1341540620		PLUNGER ASSY,INJECTION PUMP BODY	6				0111-2		V
07137	1344960600		POINTER,INJECTION PUMP BODY	1				0105-1		
07138	1342564500		RACK,INJECTION PUMP BODY	1				0105-1		
07141	1341370100		RING,INJECTION PUMP BODY	6				0105-1	0111-1	
07143C	1340470000		SCREW,INJECTION PUMP BODY	6				0105-1		
07143E	0201062040		SCREW,INJECTION PUMP BODY	2				0105-1		
07143F	0122061640		SCREW,INJECTION PUMP BODY	12				0105-1		
07144B	1342160000		SEAT,INJECTION PUMP BODY	6				0105-1		

インジェクションポンプ
13-120 INJECTION PUMP

01 6D240 CTJS07000

-64-

見出番号 REF.-NO.	部品番号 PART NO.	代 替 R / P 記 順 号 S C E N Q G	部品名称および記事・仕様記号 PART NAME & DESCRIPTION	型式・個数 MODEL & QTY				適用号機 APPLICABLE SERIAL NO.	管 区 M / R D	新 規 V R D
				0	1			FROM@- :@UPTO		
07144C	1342170500		SEAT,INJECTION PUMP BODY	6				0105-1		
07146C	1343140000		SHIM,INJECTION PUMP BODY	CC				0105-1		
	1343140100		SHIM,INJECTION PUMP BODY T=0.100	CC				0105-1		
	1343140200		SHIM,INJECTION PUMP BODY T=0.120	CC				0105-1		
	1343140300		SHIM,INJECTION PUMP BODY T=0.140	CC				0105-1		
	1343140400		SHIM,INJECTION PUMP BODY T=0.160	CC				0105-1		
	1343140500		SHIM,INJECTION PUMP BODY T=0.180	CC				0105-1		
	1343140600		SHIM,INJECTION PUMP BODY T=0.300	CC				0105-1		
	1343140600		SHIM,INJECTION PUMP BODY T=0.500	CC				0105-1		
07146CB	1343030400		SHIM,INJECTION PUMP BODY T=0.600	CC				0105-1		
	1343030000		SHIM,INJECTION PUMP BODY T=1.200	CC				0105-1		
	1343030100		SHIM,INJECTION PUMP BODY T=1.500	CC				0105-1		
	1343030200		SHIM,INJECTION PUMP BODY T=1.800	CC				0105-1		
	1343030300		SHIM,INJECTION PUMP BODY T=2.000	CC				0105-1		
07146D	1394000900		SHIM,INJECTION PUMP BODY T=0.500	CC				0105-1		
	1394001000		SHIM,INJECTION PUMP BODY T=0.525	CC				0105-1		
	1394001100		SHIM,INJECTION PUMP BODY T=0.550	CC				0105-1		
	1394001200		SHIM,INJECTION PUMP BODY T=0.575	CC				0105-1		
	1394001300		SHIM,INJECTION PUMP BODY T=0.600	CC				0105-1		
	1394001400		SHIM,INJECTION PUMP BODY T=0.625	CC				0105-1		
	1394001500		SHIM,INJECTION PUMP BODY T=0.650	CC				0105-1		
	1394001600		SHIM,INJECTION PUMP BODY T=0.675	CC				0105-1		
	1394001700		SHIM,INJECTION PUMP BODY T=0.700	CC				0105-1		
	1394001800		SHIM,INJECTION PUMP BODY T=0.725	CC				0105-1		
	1394001900		SHIM,INJECTION PUMP BODY T=0.750	CC				0105-1		
	1394002000		SHIM,INJECTION PUMP BODY T=0.775	CC				0105-1		
	1394002100		SHIM,INJECTION PUMP BODY	CC				0105-1		

インジェクションポンプ
13 -120 INJECTION PUMP

01 6D240 CTJS07000

-65-

見出番号 REF.-NO.	部品番号 PART NO.	代 替 R / P 記 順 号 S C / E N P Q G	部品名称および記事・仕様記号 PART NAME & DESCRIPTION	型式・個数 MODEL & QTY				適用号機 APPLICABLE SERIAL NO.	管 区 M / R 新 規 V / R D
				0	1			FROM@- :@UPTO	
	1394002200		T=0.800 SHIM,INJECTION PUMP BODY	CC				0105-1	
	1394002300		T=0.825 SHIM,INJECTION PUMP BODY	CC				0105-1	
	1394002400		T=0.850 SHIM,INJECTION PUMP BODY	CC				0105-1	
	1394002500		T=0.875 SHIM,INJECTION PUMP BODY	CC				0105-1	
	1394002600		T=0.900 SHIM,INJECTION PUMP BODY	CC				0105-1	
	1394002700		T=0.925 SHIM,INJECTION PUMP BODY	CC				0105-1	
	1394002800		T=0.950 SHIM,INJECTION PUMP BODY	CC				0105-1	
	1394002900		T=0.975 SHIM,INJECTION PUMP BODY	CC				0105-1	
	1394003000		T=1.000 SHIM,INJECTION PUMP BODY	CC				0105-1	
	1394003100		T=1.025 SHIM,INJECTION PUMP BODY	CC				0105-1	
	1394003200		T=1.050 SHIM,INJECTION PUMP BODY	CC				0105-1	
	1394003300		T=1.075 SHIM,INJECTION PUMP BODY	CC				0105-1	
	1394003400		T=1.100 SHIM,INJECTION PUMP BODY	CC				0105-1	
	1394003500		T=1.125 SHIM,INJECTION PUMP BODY	CC				0105-1	
	1394003600		T=1.150 SHIM,INJECTION PUMP BODY	CC				0105-1	
	1394003700		T=1.175 SHIM,INJECTION PUMP BODY	CC				0105-1	
	1394003800		T=1.200 SHIM,INJECTION PUMP BODY	CC				0105-1	
	1394003900		T=1.225 SHIM,INJECTION PUMP BODY	CC				0105-1	
	1394004000		T=1.250 SHIM,INJECTION PUMP BODY	CC				0105-1	
	1394004100		T=1.275 SHIM,INJECTION PUMP BODY	CC				0105-1	
	1394004200		T=1.300 SHIM,INJECTION PUMP BODY	CC				0105-1	
	1394004300		T=1.325 SHIM,INJECTION PUMP BODY	CC				0105-1	
	1394004400		T=1.350 SHIM,INJECTION PUMP BODY	CC				0105-1	
	1394004500		T=1.375 SHIM,INJECTION PUMP BODY	CC				0105-1	
	1394004600		T=1.400 SHIM,INJECTION PUMP BODY	CC				0105-1	

インジェクションポンプ
13-120 INJECTION PUMP

01 6D240 CTJS07000

-66-

見出番号 REF.-NO.	部品番号 PART NO.	代 替 順 号 R / S C P Q G	部品名称および記事・仕様記号 PART NAME & DESCRIPTION	型式・個数 MODEL & QTY				適用号機 APPLICABLE SERIAL NO.		管 区 M / R	新 規 V R D
				0	1			FROM@	@UPTO		
	1394004700		T=1.425 SHIM,INJECTION PUMP BODY	CC				0105-1			
	1394004800		T=1.450 SHIM,INJECTION PUMP BODY	CC				0105-1			
	1394004900		T=1.475 SHIM,INJECTION PUMP BODY	CC				0105-1			
	1394005000		T=1.500 SHIM,INJECTION PUMP BODY	CC				0105-1			
	1394005100		T=1.525 SHIM,INJECTION PUMP BODY	CC				0105-1			
	1394005200		T=1.550 SHIM,INJECTION PUMP BODY	CC				0105-1			
	1394005300		T=1.575 SHIM,INJECTION PUMP BODY	CC				0105-1			
	1394005400		T=1.600 SHIM,INJECTION PUMP BODY	CC				0105-1			
	1394005500		T=1.625 SHIM,INJECTION PUMP BODY	CC				0105-1			
	1394005600		T=1.650 SHIM,INJECTION PUMP BODY	CC				0105-1			
	1394005700		T=1.675 SHIM,INJECTION PUMP BODY	CC				0105-1			
	1394005800		T=1.700 SHIM,INJECTION PUMP BODY	CC				0105-1			
	1394005900		T=1.725 SHIM,INJECTION PUMP BODY	CC				0105-1			
	1394006000		T=1.750 SHIM,INJECTION PUMP BODY	CC				0105-1			
	1394006100		T=1.775 SHIM,INJECTION PUMP BODY	CC				0105-1			
	1394006200		T=1.800 SHIM,INJECTION PUMP BODY	CC				0105-1			
	1394006300		T=1.825 SHIM,INJECTION PUMP BODY	CC				0105-1			
	1394006400		T=1.850 SHIM,INJECTION PUMP BODY	CC				0105-1			
	1394006500		T=1.875 SHIM,INJECTION PUMP BODY	CC				0105-1			
	1394006600		T=1.900 SHIM,INJECTION PUMP BODY	CC				0105-1			
	1394006700		T=1.925 SHIM,INJECTION PUMP BODY	CC				0105-1			
	1394006800		T=1.950 SHIM,INJECTION PUMP BODY	CC				0105-1			
			T=1.975 SHIM,INJECTION PUMP BODY	CC				0105-1			
07147C	1342410021		SLEEVE,INJECTION PUMP BODY	6				0105-1			
07147D	1345630900		SLEEVE,INJECTION PUMP BODY	1				0105-1			
07148	0296020010		SNAP RING,INJECTION PUMP BODY	6				0105-1			
07149B	1341120600		SPRING,INJECTION PUMP BODY	6				0105-1			
07149C	1342150400		SPRING,INJECTION PUMP BODY	6				0105-1			

1/2

07040A

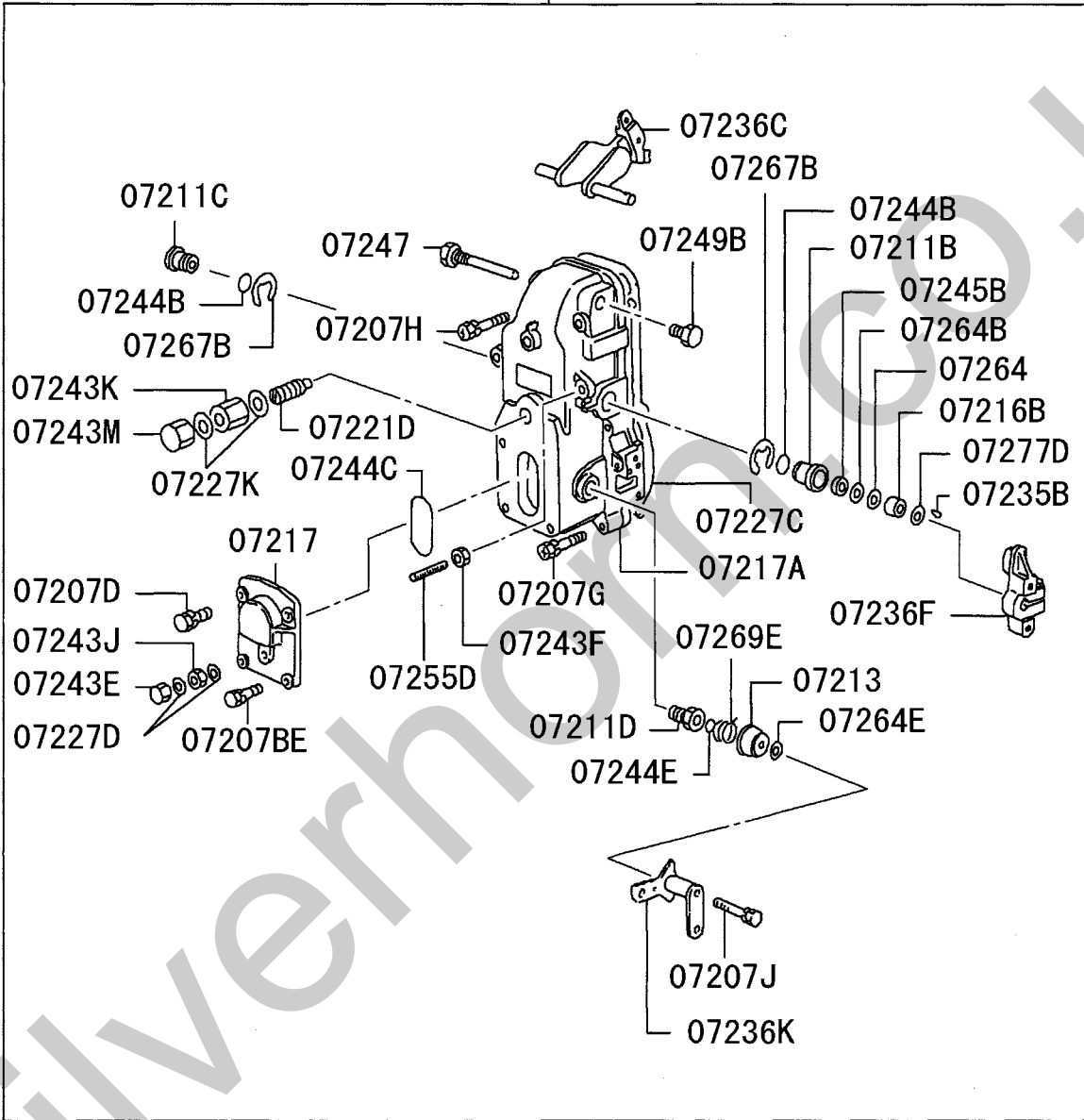

2/2

(-0111. 1)

07040A

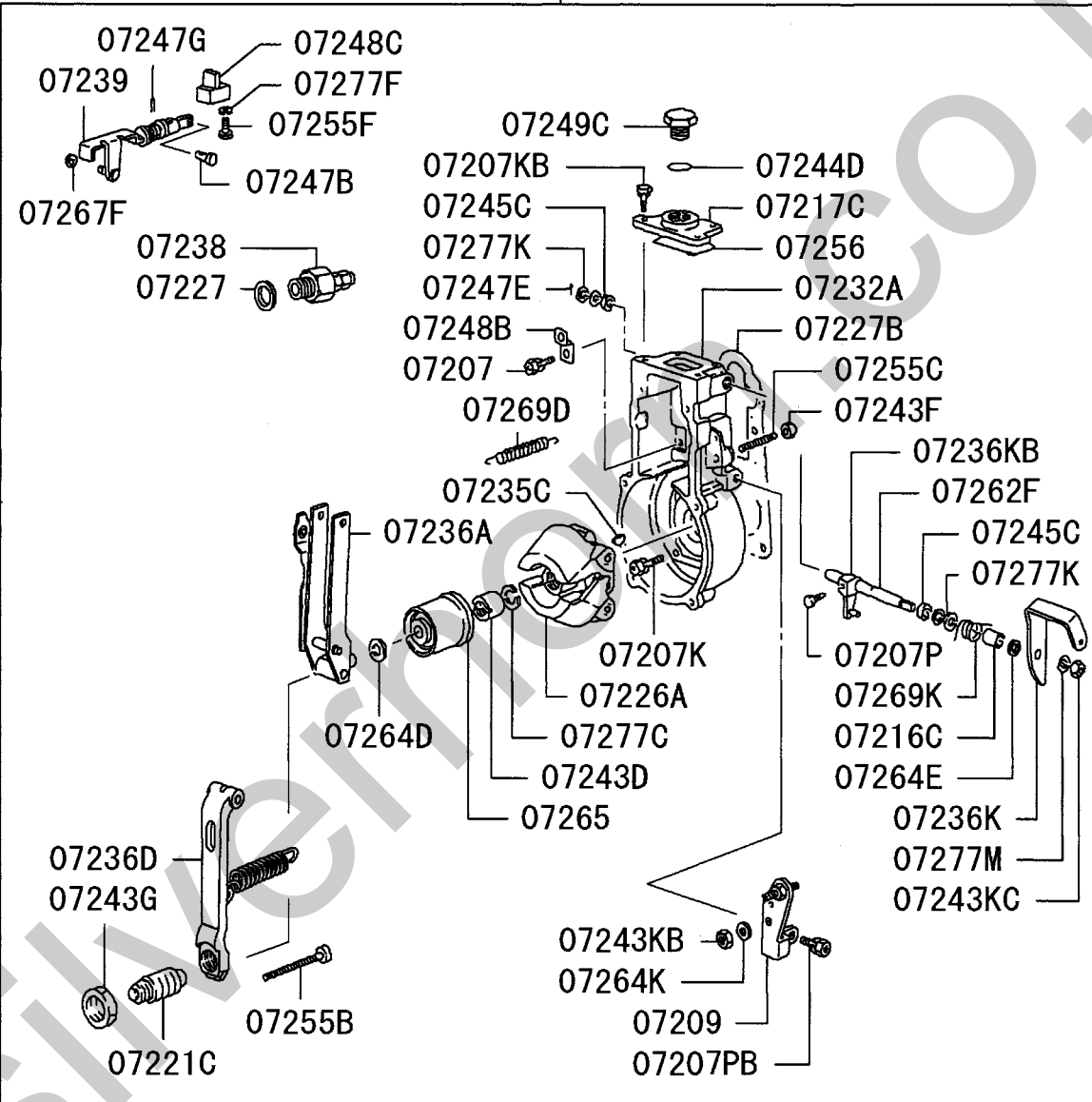

213T02

07040A

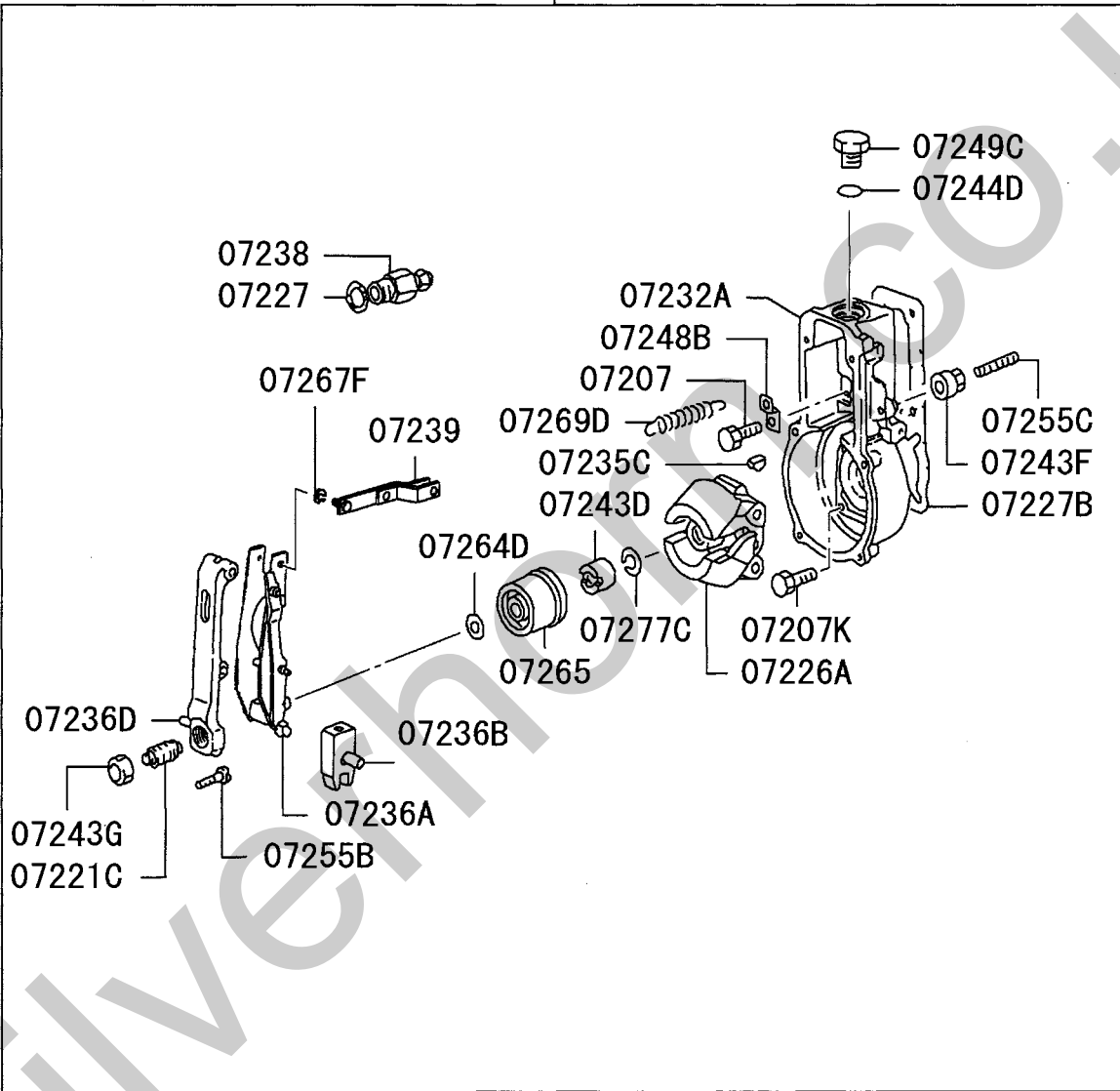

見出番号 REF.-NO.	部品番号 PART NO.	代 替 順 号 / P SC EN QG	部品名称および記事・仕様記号 PART NAME & DESCRIPTION	型式・個数 MODEL & QTY					適用号機 APPLICABLE SERIAL NO.		管 区 M / R	新 規 V R D
				0	1				FROM@-	@UPTO		
07040A	1054078050		GOVERNOR ASSY,INJECTION PUMP RSV	1					0105-1	0111-1		
	1054078110		GOVERNOR ASSY,INJECTION PUMP RSV	1					0111-2			
07207	0201062040		BOLT,INJECTION PUMP GOVERNOR	1					0105-1			
07207BE	0290206210		BOLT,INJECTION PUMP GOVERNOR	2					0105-1			
07207D	0200061640		BOLT,INJECTION PUMP GOVERNOR	2					0105-1			
07207G	0201063640		BOLT,INJECTION PUMP GOVERNOR	4					0105-1			
07207H	0201065040		BOLT,INJECTION PUMP GOVERNOR	2					0105-1			
07207J	0200064540		BOLT,INJECTION PUMP GOVERNOR	1					0111-2			V
07207K	0201062040		BOLT,INJECTION PUMP GOVERNOR	7					0105-1			
07207KB	0200061640		BOLT,INJECTION PUMP GOVERNOR	4					0105-1	0111-1		
07207P	1550060700		BOLT,INJECTION PUMP GOVERNOR	1					0105-1	0111-1		
07207PB	0201181640		BOLT,INJECTION PUMP GOVERNOR	1					0105-1	0111-1		
07209	1543589420		BRACKET,INJECTION PUMP GOVERNOR	1					0105-1	0111-1		
07211B	1542044300		BUSHING,INJECTION PUMP GOVERNOR	1					0105-1			
07211C	1542044400		BUSHING,INJECTION PUMP GOVERNOR	1					0105-1			
07211D	1543210400		BUSHING,INJECTION PUMP GOVERNOR	1					0111-2			V
07213	1543220100		CAP,INJECTION PUMP GOVERNOR	1					0111-2			V
07216B	1542062800		COLLAR,INJECTION PUMP GOVERNOR	1					0105-1			
07216C	1542062000		COLLAR,INJECTION PUMP GOVERNOR	1					0105-1	0111-1		
07217	1540631400		COVER,INJECTION PUMP GOVERNOR	1					0105-1			
07217A	1545002020		COVER ASSY,INJECTION PUMP GOVERNOR	1					0105-1	0111-1		
	1545003020		COVER ASSY,INJECTION PUMP GOVERNOR	1					0111-2			V
07217C	1540644500		COVER,INJECTION PUMP GOVERNOR	1					0105-1	0111-1		
07221C	1541770720		DAMPER,INJECTION PUMP GOVERNOR	1					0105-1	0111-1		
	1541770920		DAMPER,INJECTION PUMP GOVERNOR	1					0111-2			V
07221D	1541580820		DAMPER,INJECTION PUMP GOVERNOR	1					0105-1			
07226A	1541010020		FLYWEIGHT ASSY,INJECTION PUMP GOVERNOR	1					0105-1			
07227	0265243040		GASKET,INJECTION PUMP GOVERNOR	1					0105-1			
07227B	1543715600		GASKET,INJECTION PUMP GOVERNOR	1					0105-1			
07227C	1543900300		GASKET,INJECTION PUMP GOVERNOR	1					0105-1			
07227D	0265061040		GASKET,INJECTION PUMP GOVERNOR	2					0105-1			
07227K	0265121540		GASKET,INJECTION PUMP GOVERNOR	2					0105-1			
07232A	1540042822		HOUSING ASSY,INJECTION PUMP GOVERNOR	1					0105-1	0111-1		
	1540004700		HOUSING ASSY,INJECTION PUMP GOVERNOR	1					0111-2			V
07235B	0258031310		KEY,INJECTION PUMP GOVERNOR	1					0105-1			
07235C	0258031610		KEY,INJECTION PUMP GOVERNOR	1					0105-1	0111-1		
	0258031310		KEY,INJECTION PUMP GOVERNOR	1					0105-1			
07236A	1542171420		LEVER ASSY,INJECTION PUMP GOVERNOR	1					0105-1	0111-1		
	1542114320		LEVER ASSY,INJECTION PUMP GOVERNOR	1					0111-2			V
07236B	1543265120		LEVER,INJECTION PUMP GOVERNOR	1					0111-2			V
07236C	1542006920		LEVER,INJECTION PUMP GOVERNOR	1					0105-1			
07236D	1542393320		LEVER,INJECTION PUMP GOVERNOR	1					0105-1			
07236F	1543400120		LEVER,INJECTION PUMP GOVERNOR	1					0105-1			
07236K	1543817900		LEVER,INJECTION PUMP GOVERNOR	1					0105-1	0111-1		
	1543643420		LEVER,INJECTION PUMP GOVERNOR	1					0111-2			V
07236KB	1550032101		LEVER,INJECTION PUMP GOVERNOR	1					0105-1	0111-1		
07238	1530212220		LIMITER,INJECTION PUMP GOVERNOR	1					0105-1			
07239	1542346920		LINK,INJECTION PUMP GOVERNOR	1					0105-1	0111-1		

ガバナ
13-160 GOVERNOR

01 6D240 CTJS07000

-72-

見出番号 REF.-NO.	部品番号 PART NO.	代 替 R / P 記 順 号 S C E N E Q G	部品名称および記事・仕様記号 PART NAME & DESCRIPTION	型式・個数 MODEL & QTY					適用号機 APPLICABLE SERIAL NO.		管 区 M / R D	新 規 V / R D
				0	1					FROM@-		
07243D	1542302920		LINK,INJECTION PUMP GOVERNOR	1						0111・2		V
07243E	0292312030		NUT,INJECTION PUMP GOVERNOR	1						0105・1		
07243F	1540351600		NUT,INJECTION PUMP GOVERNOR	1						0105・1		
07243G	1540110100		NUT,INJECTION PUMP GOVERNOR	2						0105・1		
07243H	0292016010		NUT,INJECTION PUMP GOVERNOR	1						0105・1		
07243J	1392060600		NUT,INJECTION PUMP GOVERNOR	1						0105・1		
07243K	1540111700		NUT,INJECTION PUMP GOVERNOR	1						0105・1		
07243KB	1540111100		NUT,INJECTION PUMP GOVERNOR	1						0105・1	0111・1	
07243KC	0130208040		NUT,INJECTION PUMP GOVERNOR	1						0105・1	0111・1	
07243M	1541591200		NUT,INJECTION PUMP GOVERNOR	1						0105・1		
07244B	0296318020		O-RING,INJECTION PUMP GOVERNOR	2						0105・1		
07244C	0296352020		O-RING,INJECTION PUMP GOVERNOR	1						0105・1		
07244D	0296325070		O-RING,INJECTION PUMP GOVERNOR	1						0105・1		
07244E	0296310030		O-RING,INJECTION PUMP GOVERNOR	1						0111・2		V
07245B	1396110000		OIL SEAL,INJECTION PUMP GOVERNOR	1						0105・1		
07245C	0296208050		OIL SEAL,INJECTION PUMP GOVERNOR	2						0105・1	0111・1	
07247	1542371100		PIN,INJECTION PUMP GOVERNOR	1						0105・1		
07247B	1542314900		PIN,INJECTION PUMP GOVERNOR	1						0105・1	0111・1	
07247E	1543732200		PIN,INJECTION PUMP GOVERNOR	1						0105・1	0111・1	
07247G	1554023800		PIN,INJECTION PUMP GOVERNOR	1						0105・1	0111・1	
			SNAP									
07248B	1543506000		PLATE,INJECTION PUMP GOVERNOR	1						0105・1		
07248C	1542322420		PLATE,INJECTION PUMP GOVERNOR	1						0105・1	0111・1	
07249B	1540360300		PLUG,INJECTION PUMP GOVERNOR	1						0105・1		
07249C	1540072900		PLUG,INJECTION PUMP GOVERNOR	1						0105・1		
07255B	1540312400		SCREW,INJECTION PUMP GOVERNOR	1						0105・1		
07255C	1540101100		SCREW,INJECTION PUMP GOVERNOR	1						0105・1		
07255D	1540100100		SCREW,INJECTION PUMP GOVERNOR L=55	1						0105・1		
07255F	0105351040		SCREW,INJECTION PUMP GOVERNOR	1						0105・1	0111・1	
07256	1543582500		SEAL RING,INJECTION PUMP GOVERNOR	1						0105・1	0111・1	
07262F	1550043600		SHAFT,INJECTION PUMP GOVERNOR	1						0105・1	0111・1	
07264	0293111070		SHIM,INJECTION PUMP GOVERNOR T=0.5	AR						0105・1		
07264B	1394110000		SHIM,INJECTION PUMP GOVERNOR	1						0105・1		
07264D	0293110010		SHIM,INJECTION PUMP GOVERNOR T=0.20	CC						0105・1		
	0293110180		SHIM,INJECTION PUMP GOVERNOR T=0.30	CC						0105・1		
	0293110190		SHIM,INJECTION PUMP GOVERNOR T=0.40	CC						0105・1		
	1394100000		SHIM,INJECTION PUMP GOVERNOR T=0.50	CC						0105・1		
	0293110210		SHIM,INJECTION PUMP GOVERNOR T=1.00	CC						0105・1		
	1394100100		SHIM,INJECTION PUMP GOVERNOR T=1.50	CC						0105・1		
	1394103000		SHIM,INJECTION PUMP GOVERNOR T=2.00	CC						0105・1		
	1394103100		SHIM,INJECTION PUMP GOVERNOR	CC						0105・1		

ガバナ
13-160 GOVERNOR

01 6D240 CTJS07000

-73-

見出番号 REF.-NO.	部品番号 PART NO.	代 替 R / P 変 更 順 号 S C E N E N G Q G	部品名称および記事・仕様記号 PART NAME & DESCRIPTION	型式・個数 MODEL & QTY				適用号機 APPLICABLE SERIAL NO.		管 区 M / R 新 規 V / R D
				0	1			FROM@-	@UPTO	
07264E	1394103200		T=3.00 SHIM,INJECTION PUMP GOVERNOR	CC				0105-1		
	1394081400		T=4.00 SHIM,INJECTION PUMP GOVERNOR	CC				0105-1	0111-1	
	1394081500		T=0.20 SHIM,INJECTION PUMP GOVERNOR	CC				0105-1	0111-1	
	0293110520		T=0.50 SHIM,INJECTION PUMP GOVERNOR	CC				0111-2		V
	0293110530		T=0.20 SHIM,INJECTION PUMP GOVERNOR	CC				0111-2		V
	0293110540		T=0.25 SHIM,INJECTION PUMP GOVERNOR	CC				0111-2		V
	0293110550		T=0.30 SHIM,INJECTION PUMP GOVERNOR	CC				0111-2		V
	0293110560		T=0.35 SHIM,INJECTION PUMP GOVERNOR	CC				0111-2		V
	0293110570		T=0.40 SHIM,INJECTION PUMP GOVERNOR	CC				0111-2		V
	0293008320		T=0.50 SHIM,INJECTION PUMP GOVERNOR	1				0105-1	0111-1	
07265	1541232320		SLEEVE,INJECTION PUMP GOVERNOR	1				0105-1		
07267B	0160101640		SNAP RING,INJECTION PUMP GOVERNOR	2				0105-1		
07267F	0160100540		SNAP RING,INJECTION PUMP GOVERNOR	1				0105-1		
07269D	1541540500		SPRING,INJECTION PUMP GOVERNOR	1				0105-1		
07269E	1543277300		SPRING,INJECTION PUMP GOVERNOR	1				0111-2		V
07269K	1543274200		SPRING,INJECTION PUMP GOVERNOR	1				0105-1	0111-1	
07277C	0293212020		WASHER,INJECTION PUMP GOVERNOR SPRING	1				0105-1		
07277D	1542060200		WASHER,INJECTION PUMP GOVERNOR T=1.0	AR				0105-1		
07277F	0293205020		WASHER,INJECTION PUMP GOVERNOR	1				0105-1	0111-1	
07277K	1393080900		WASHER,INJECTION PUMP GOVERNOR T=1.00	CC				0105-1	0111-1	
	1393081000		WASHER,INJECTION PUMP GOVERNOR T=1.50	CC				0105-1	0111-1	
07277M	F251508000		WASHER,INJECTION PUMP GOVERNOR SPRING,8	1				0105-1	0111-1	

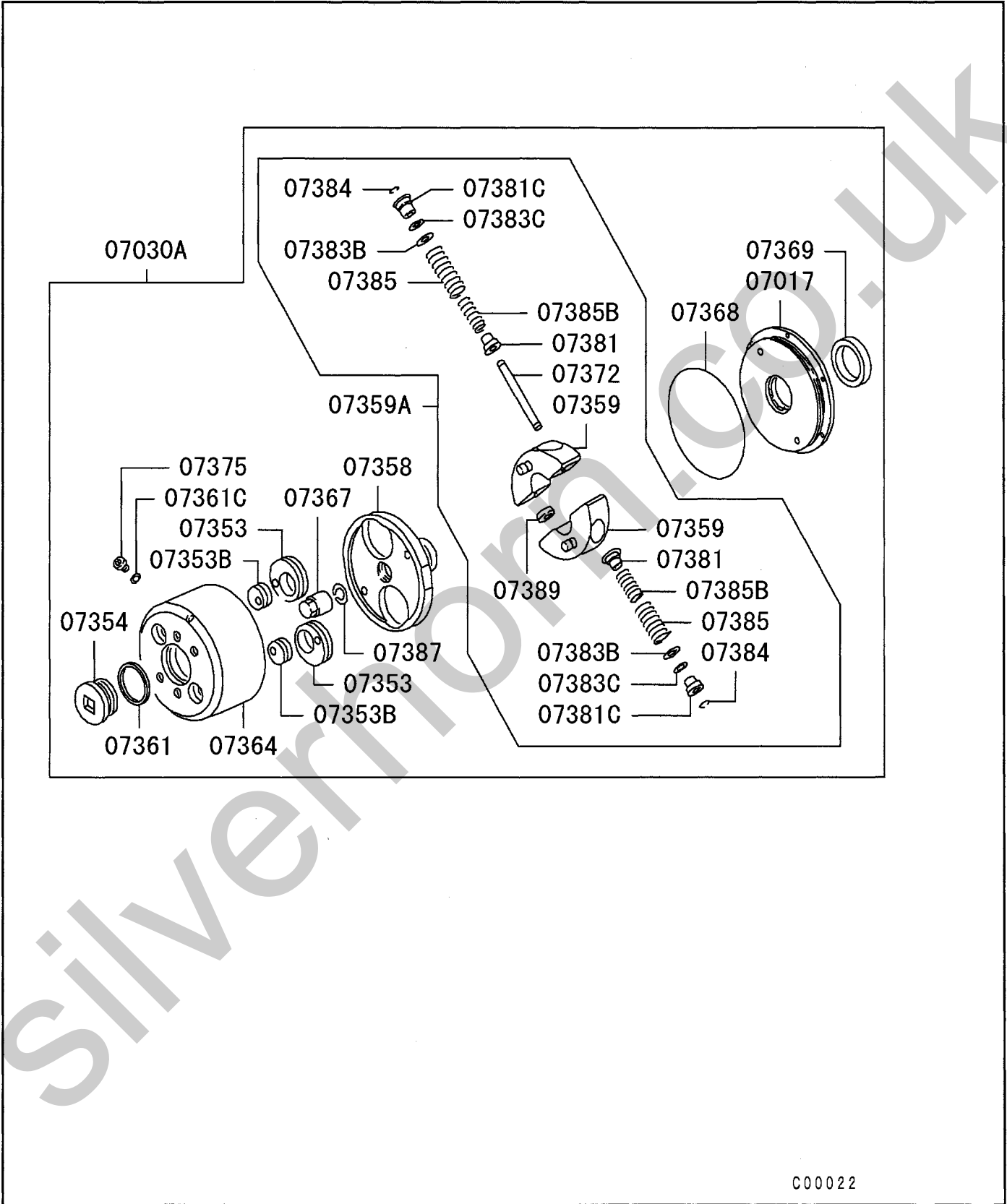

オートマチックタイ
13 -270 AUTOMATIC TIMER

01 6D240 CTJS07000

-75-

見出番号 REF.-NO.	部品番号 PART NO.	代 替 R / P 変 記 順 号 S C E N Q G	部品名称および記事・仕様記号 PART NAME & DESCRIPTION	型式・個数 MODEL & QTY					適用号機 APPLICABLE SERIAL NO.		新 規 区 M / R D
				0	1				FROM@-	@UPTO	
07017	1568091620		COVER,INJECTION PUMP TIMER	1					0105-1		
07030A	1056812790		TIMER ASSY,INJECTION PUMP	1					0105-1		
07353	1567230300		CAM,INJECTION PUMP TIMER	2					0105-1		
07353B	1567230400		CAM,INJECTION PUMP TIMER	2					0105-1		
07354	1563140600		CAP,INJECTION PUMP TIMER	1					0105-1		
07358	1568016200		FLANGE,INJECTION PUMP TIMER	1					0105-1		
07359	1568020420		FLYWEIGHT,INJECTION PUMP TIMER	2					0105-1		
07359A	1568986220		FLYWEIGHT ASSY,INJECTION PUMP TIMER	1					0105-1		
07361	1563190200		GASKET,INJECTION PUMP TIMER	1					0105-1		
07361C	0293310190		GASKET,INJECTION PUMP TIMER	1					0105-1		
07364	1568003420		HOUSING,INJECTION PUMP TIMER	1					0105-1		
07367	1343250800		NUT,INJECTION PUMP TIMER	1					0105-1		
07368	1563150200		O-RING,INJECTION PUMP TIMER	1					0105-1		
07369	1396480300		OIL SEAL,INJECTION PUMP TIMER	1					0105-1		
07372	1568060900		PIN,INJECTION PUMP TIMER	2					0105-1		
07375	1563160000		PLUG,INJECTION PUMP TIMER	1					0105-1		
07381	1568071100		SEAT,INJECTION PUMP TIMER	4					0105-1		
07381C	1568070900		SEAT,INJECTION PUMP TIMER	4					0105-1		
07383B	1567280800		SHIM,INJECTION PUMP TIMER T=0.10	CC					0105-1		
	1567280900		SHIM,INJECTION PUMP TIMER T=0.30	CC					0105-1		
	1567282000		SHIM,INJECTION PUMP TIMER T=0.40	CC					0105-1		
	1567281000		SHIM,INJECTION PUMP TIMER T=0.50	CC					0105-1		
	1567282100		SHIM,INJECTION PUMP TIMER T=0.70	CC					0105-1		
	1567281100		SHIM,INJECTION PUMP TIMER T=1.00	CC					0105-1		
07383C	1567281200		SHIM,INJECTION PUMP TIMER T=0.10	CC					0105-1		
	1567281300		SHIM,INJECTION PUMP TIMER T=0.30	CC					0105-1		
	1567282200		SHIM,INJECTION PUMP TIMER T=0.40	CC					0105-1		
	1567281400		SHIM,INJECTION PUMP TIMER T=0.50	CC					0105-1		
	1567282300		SHIM,INJECTION PUMP TIMER T=0.70	CC					0105-1		
	1567281500		SHIM,INJECTION PUMP TIMER T=1.00	CC					0105-1		
07384	1568090300		SNAP RING,INJECTION PUMP TIMER	4					0105-1		
07385	1568957300		SPRING,INJECTION PUMP TIMER	4					0105-1		
07385B	1568946100		SPRING,INJECTION PUMP TIMER	4					0105-1		
07387	1563220000		WASHER,INJECTION PUMP TIMER	1					0105-1		
07389	1568080500		SPACER,INJECTION PUMP TIMER	4					0105-1		

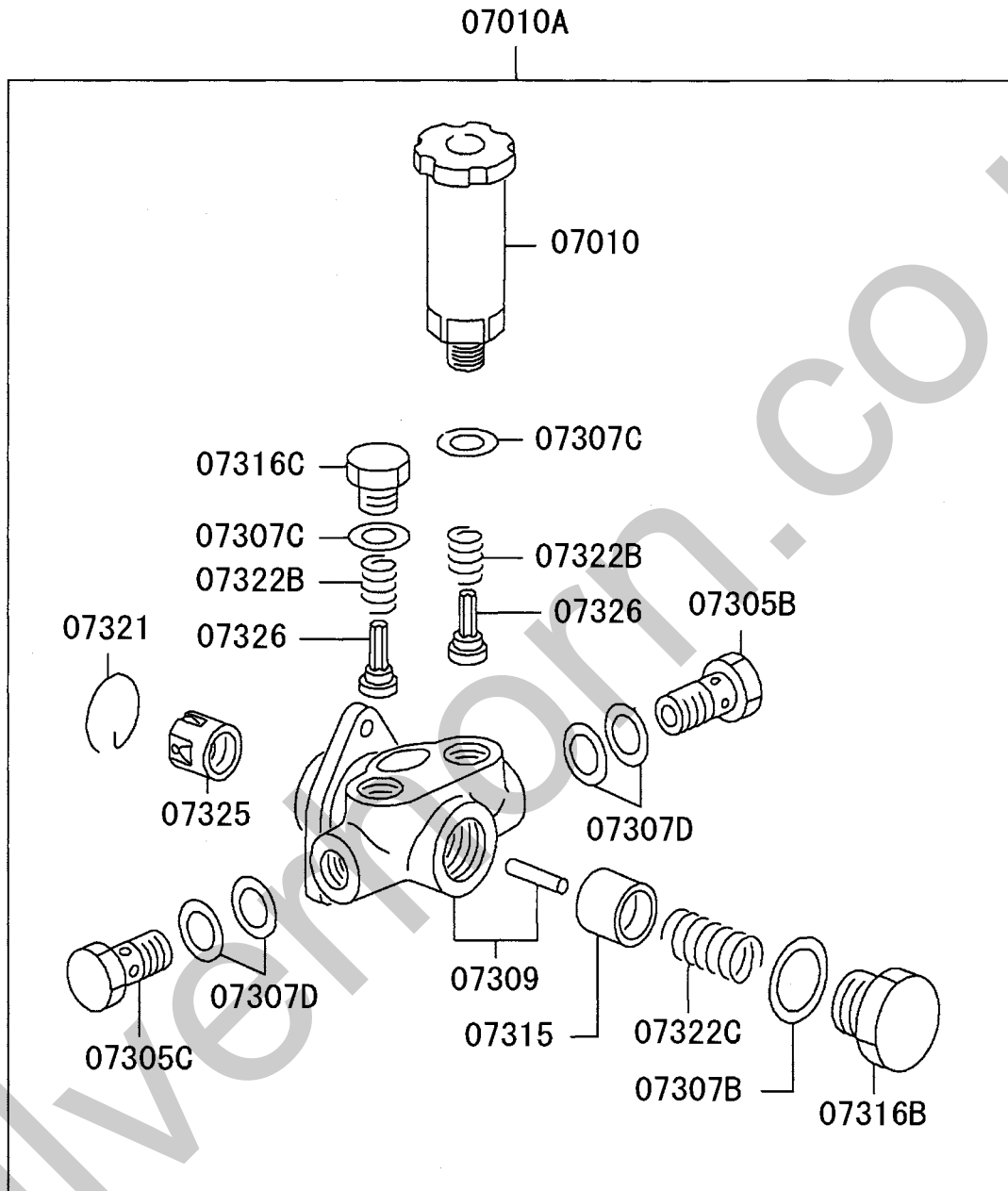

13 -290 FUEL FEED PUMP

フューエルフィードポンプ

01 6D240 CTJS07000

-77-

見出番号 REF.-NO.	部品番号 PART NO.	代 替 R / P	変 更 順 号 S C E N Q G	部品名称および記事・仕様記号 PART NAME & DESCRIPTION	型式・個数 MODEL & QTY					適用号機 APPLICABLE SERIAL NO.		管 区 M / R	新 規 V R D
					0	1					FROM@-		
07010	1522005620			PUMP,INJECTION PUMP FUEL FEED	1						0105-1		
07010A	1052071200 (1052106070)	3		PUMP ASSY,INJECTION PUMP FUEL FEED	1						0105-1		
07305B	1523007120			EYEBOLT,INJECTION PUMP FUEL FEED PUMP	1						0105-1		
07305C	0297314570			EYEBOLT,INJECTION PUMP FUEL FEED PUMP	1						0105-1		
07307B	0293326030			GASKET,INJECTION PUMP FUEL FEED PUMP	1						0105-1		
07307C	0293316030			GASKET,INJECTION PUMP FUEL FEED PUMP	2						0105-1		
07307D	0293414130			GASKET,INJECTION PUMP FUEL FEED PUMP	4						0105-1		
07309	1520004620			HOUSING,INJECTION PUMP FUEL FEED PUMP	1						0105-1		
07315	1521001120			PISTON,INJECTION PUMP FUEL FEED PUMP	1						0105-1		
07316B	1521051500			PLUG,INJECTION PUMP FUEL FEED PUMP	1						0105-1		
07316C	1521170400			PLUG,INJECTION PUMP FUEL FEED PUMP	1						0105-1		
07321	1521210200			SNAP RING,INJECTION PUMP FUEL FEED PUMP	1						0105-1		
07322B	1521160200			SPRING,INJECTION PUMP FUEL FEED PUMP	2						0105-1		
07322C	1521020400			SPRING,INJECTION PUMP FUEL FEED PUMP	1						0105-1		
07325	1521113221			TAPPET,INJECTION PUMP FUEL FEED PUMP	1						0105-1		
07326	1521150200			VALVE,INJECTION PUMP FUEL FEED PUMP	2						0105-1		

13 -320 カップリング COUPLING

-78-

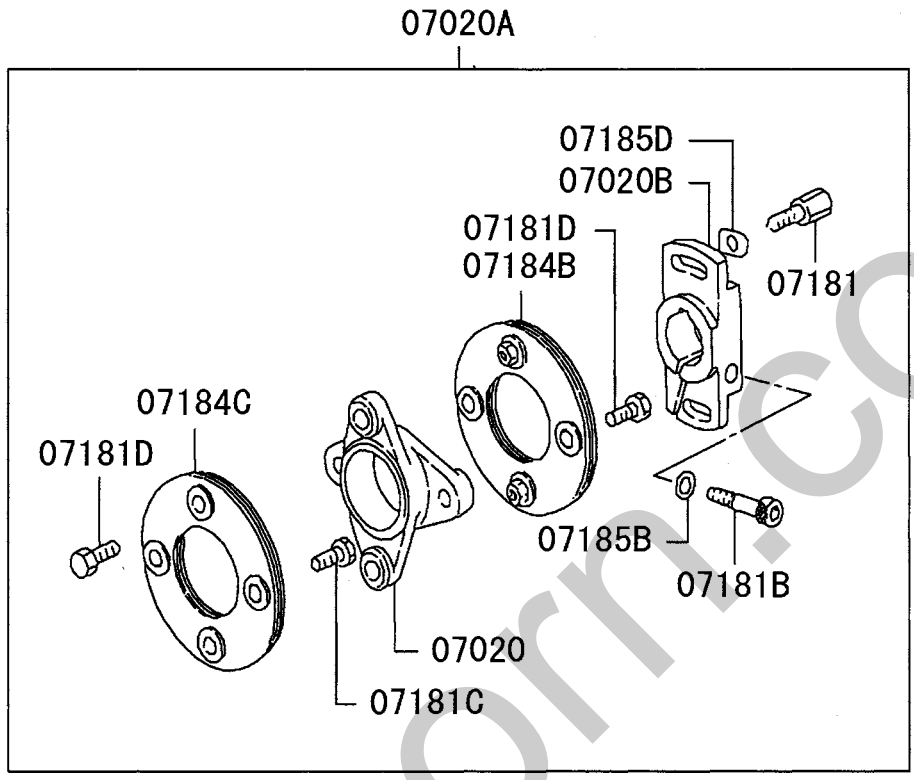

213T01

インジェクションパイプ & ノズル
 13-410 INJECTION PIPE & NOZZLE

-80-

INJECTION PIPE

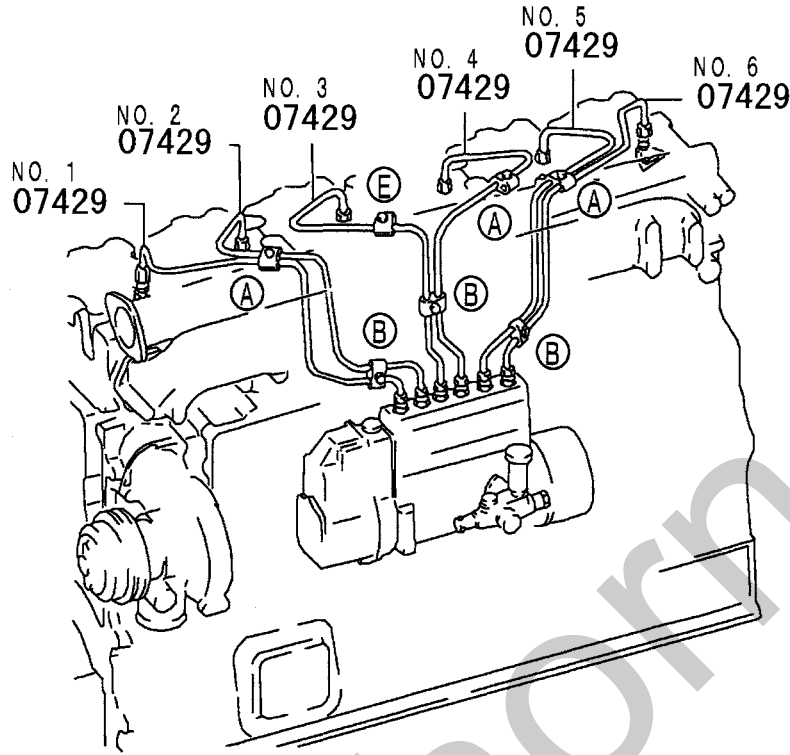

- (A)
 - 07499C
 - 07498F
- (B)
 - 07499C
 - 07498F
 - 07498G
- (E) (-0405・3)
 - 07499C
 - 07498F
 - 07499B
 - 07495
- (E)
 - 07497B
 - 07498F
 - 07499B
 - 07495H

INJECTION NOZZLE

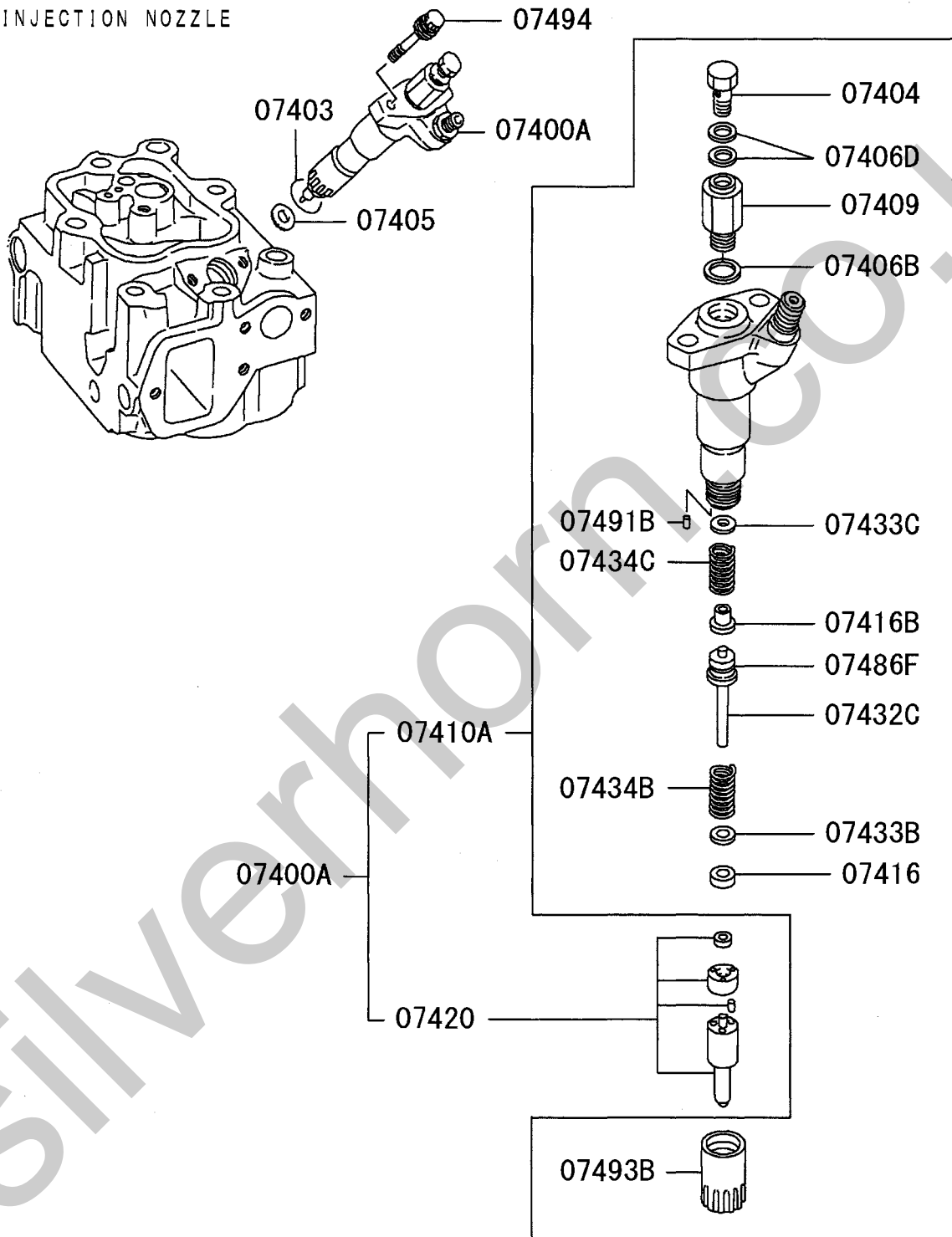

13-410 INJECTION PIPE & NOZZLE

インジェクションパイプ & ノズル

01 6D240 CTJS07000

-82-

見出番号 REF.-NO.	部品番号 PART NO.	代 替 順 号 R / P SC EN QG	部品名称および記事・仕様記号 PART NAME & DESCRIPTION	型式・個数 MODEL & QTY					適用号機 APPLICABLE SERIAL NO.		管 区 M / R	新 規 V R D
				0	1				FROM@-	@UPTO		
07400A	1051107550		NOZZLE & HOLDER ASSY,FUEL INJECTION ZEXEL	6						0105-1		
07403	3096102200		DUST SEAL,FUEL INJECTION NOZZLE HOLDER	6						0105-1		
07404	1506131700		EYEBOLT,FUEL INJECTION NOZZLE	6						0105-1		
07405	3096102300		GASKET,FUEL INJECTION NOZZLE	6						0105-1		
07406B	0293310240		GASKET,FUEL INJECTION NOZZLE INR	6						0105-1		
07406D	0265081240		GASKET,FUEL INJECTION NOZZLE INR	12						0105-1		
07409	1506098100		CONNECTOR,FUEL INJECTION NOZZLE	6						0105-1		
07410A	1050414130		HOLDER ASSY,FUEL INJECTION NOZZLE	6						0105-1		
07416	1505602100		SEAT,FUEL INJECTION NOZZLE HOLDER	6						0105-1		
07416B	1505602001		SEAT,FUEL INJECTION NOZZLE HOLDER	6						0105-1		
07420	1050190700		NOZZLE,FUEL INJECTION	6						0105-1		
07429	ME158221		TUBE,FUEL INJECTION 6.35X2.0X650 NO.1	1						0105-1		
	ME158222		TUBE,FUEL INJECTION 6.35X2.0X650 NO.2	1						0105-1		
	ME158223		TUBE,FUEL INJECTION 6.35X2.0X650 NO.3	1						0105-1		
	ME158224		TUBE,FUEL INJECTION 6.35X2.0X650 NO.4	1						0105-1		
	ME158225		TUBE,FUEL INJECTION 6.35X2.0X650 NO.5	1						0105-1		
	ME158226		TUBE,FUEL INJECTION 6.35X2.0X650 NO.6	1						0105-1		
07432C	1505830000		PUSH ROD,FUEL INJECTION NOZZLE HOLDER L=36.06	CC						0105-1		
	1505830100		PUSH ROD,FUEL INJECTION NOZZLE HOLDER L=36.07	CC						0105-1		
	1505830200		PUSH ROD,FUEL INJECTION NOZZLE HOLDER L=36.08	CC						0105-1		
	1505830300		PUSH ROD,FUEL INJECTION NOZZLE HOLDER L=36.09	CC						0105-1		
	1505830400		PUSH ROD,FUEL INJECTION NOZZLE HOLDER L=36.10	CC						0105-1		
	1505830500		PUSH ROD,FUEL INJECTION NOZZLE HOLDER L=36.11	CC						0105-1		
	1505830600		PUSH ROD,FUEL INJECTION NOZZLE HOLDER L=36.12	CC						0105-1		
	1505830700		PUSH ROD,FUEL INJECTION NOZZLE HOLDER L=36.13	CC						0105-1		
	1505830800		PUSH ROD,FUEL INJECTION NOZZLE HOLDER L=36.14	CC						0105-1		
	1505830900		PUSH ROD,FUEL INJECTION NOZZLE HOLDER L=36.15	CC						0105-1		
	1505831000		PUSH ROD,FUEL INJECTION NOZZLE HOLDER L=36.16	CC						0105-1		
	1505831100		PUSH ROD,FUEL INJECTION NOZZLE HOLDER L=36.17	CC						0105-1		
	1505831200		PUSH ROD,FUEL INJECTION NOZZLE HOLDER L=36.18	CC						0105-1		

インジェクションパイプ & ノズル
13 -410 INJECTION PIPE & NOZZLE

01 6D240 CTJS07000

-83-

見出番号 REF.-NO.	部品番号 PART NO.	代 替 R / P 変 更 順 号 S C E N E R I O S Q Q	部品名称および記事・仕様記号 PART NAME & DESCRIPTION	型式・個数 MODEL & QTY				適用号機 APPLICABLE SERIAL NO.		管 区 M / R 新 規 V R D
				0	1			FROM@-	@UPTO	
	1505831300		PUSH ROD,FUEL INJECTION NOZZLE HOLDER L=36.19	CC				0105-1		
	1505831400		PUSH ROD,FUEL INJECTION NOZZLE HOLDER L=36.20	CC				0105-1		
	1505831500		PUSH ROD,FUEL INJECTION NOZZLE HOLDER L=36.21	CC				0105-1		
	1505831600		PUSH ROD,FUEL INJECTION NOZZLE HOLDER L=36.22	CC				0105-1		
	1505831700		PUSH ROD,FUEL INJECTION NOZZLE HOLDER L=36.23	CC				0105-1		
	1505831800		PUSH ROD,FUEL INJECTION NOZZLE HOLDER L=36.24	CC				0105-1		
	1505831900		PUSH ROD,FUEL INJECTION NOZZLE HOLDER L=36.25	CC				0105-1		
	1505832000		PUSH ROD,FUEL INJECTION NOZZLE HOLDER L=36.26	CC				0105-1		
	1505832100		PUSH ROD,FUEL INJECTION NOZZLE HOLDER L=36.27	CC				0105-1		
	1505832200		PUSH ROD,FUEL INJECTION NOZZLE HOLDER L=36.28	CC				0105-1		
	1505832300		PUSH ROD,FUEL INJECTION NOZZLE HOLDER L=36.29	CC				0105-1		
	1505832400		PUSH ROD,FUEL INJECTION NOZZLE HOLDER L=36.30	CC				0105-1		
	1505832500		PUSH ROD,FUEL INJECTION NOZZLE HOLDER L=36.31	CC				0105-1		
	1505832600		PUSH ROD,FUEL INJECTION NOZZLE HOLDER L=36.32	CC				0105-1		
	1505832700		PUSH ROD,FUEL INJECTION NOZZLE HOLDER L=36.33	CC				0105-1		
	1505832800		PUSH ROD,FUEL INJECTION NOZZLE HOLDER L=36.34	CC				0105-1		
	1505832900		PUSH ROD,FUEL INJECTION NOZZLE HOLDER L=36.35	CC				0105-1		
	1505833000		PUSH ROD,FUEL INJECTION NOZZLE HOLDER L=36.36	CC				0105-1		
	1505833100		PUSH ROD,FUEL INJECTION NOZZLE HOLDER L=36.37	CC				0105-1		
	1505833200		PUSH ROD,FUEL INJECTION NOZZLE HOLDER L=36.38	CC				0105-1		
	1505833300		PUSH ROD,FUEL INJECTION NOZZLE HOLDER L=36.39	CC				0105-1		
	1505833400		PUSH ROD,FUEL INJECTION NOZZLE HOLDER L=36.40	CC				0105-1		
	1505833500		PUSH ROD,FUEL INJECTION NOZZLE HOLDER L=36.41	CC				0105-1		
	1505833600		PUSH ROD,FUEL INJECTION NOZZLE HOLDER L=36.42	CC				0105-1		
	1505833700		PUSH ROD,FUEL INJECTION NOZZLE HOLDER L=36.43	CC				0105-1		

13 -410 INJECTION PIPE & NOZZLE

インジェクションパイプ & ノズル

01 6D240 CTJS07000

-84-

見出番号 REF.-NO.	部品番号 PART NO.	代 替 順 号 R / P	変 更 順 号 S C E N E Q G	部品名称および記事・仕様記号 PART NAME & DESCRIPTION	型式・個数 MODEL & QTY				適用号機 APPLICABLE SERIAL NO.		管 区 M / R	新 規 V R D
					0	1			FROM@-	@UPTO		
	1505833800			PUSH ROD,FUEL INJECTION NOZZLE HOLDER L=36.44	CC					0105-1		
	1505833900			PUSH ROD,FUEL INJECTION NOZZLE HOLDER L=36.45	CC					0105-1		
	1505834000			PUSH ROD,FUEL INJECTION NOZZLE HOLDER L=36.46	CC					0105-1		
	1505834100			PUSH ROD,FUEL INJECTION NOZZLE HOLDER L=36.47	CC					0105-1		
	1505834200			PUSH ROD,FUEL INJECTION NOZZLE HOLDER L=36.48	CC					0105-1		
	1505834300			PUSH ROD,FUEL INJECTION NOZZLE HOLDER L=36.49	CC					0105-1		
	1505834400			PUSH ROD,FUEL INJECTION NOZZLE HOLDER L=36.50	CC					0105-1		
	1505834500			PUSH ROD,FUEL INJECTION NOZZLE HOLDER L=36.51	CC					0105-1		
	1505834600			PUSH ROD,FUEL INJECTION NOZZLE HOLDER L=36.52	CC					0105-1		
	1505834700			PUSH ROD,FUEL INJECTION NOZZLE HOLDER L=36.53	CC					0105-1		
	1505834800			PUSH ROD,FUEL INJECTION NOZZLE HOLDER L=36.54	CC					0105-1		
	1505834900			PUSH ROD,FUEL INJECTION NOZZLE HOLDER L=36.55	CC					0105-1		
	1505835000			PUSH ROD,FUEL INJECTION NOZZLE HOLDER L=36.56	CC					0105-1		
	1505835100			PUSH ROD,FUEL INJECTION NOZZLE HOLDER L=36.57	CC					0105-1		
	1505835200			PUSH ROD,FUEL INJECTION NOZZLE HOLDER L=36.58	CC					0105-1		
	1505835300			PUSH ROD,FUEL INJECTION NOZZLE HOLDER L=36.59	CC					0105-1		
	1505835400			PUSH ROD,FUEL INJECTION NOZZLE HOLDER L=36.60	CC					0105-1		
	1505835500			PUSH ROD,FUEL INJECTION NOZZLE HOLDER L=36.61	CC					0105-1		
	1505835600			PUSH ROD,FUEL INJECTION NOZZLE HOLDER L=36.62	CC					0105-1		
	1505835700			PUSH ROD,FUEL INJECTION NOZZLE HOLDER L=36.63	CC					0105-1		
	1505835800			PUSH ROD,FUEL INJECTION NOZZLE HOLDER L=36.64	CC					0105-1		
	1505835900			PUSH ROD,FUEL INJECTION NOZZLE HOLDER L=36.65	CC					0105-1		
	1505836000			PUSH ROD,FUEL INJECTION NOZZLE HOLDER L=36.66	CC					0105-1		
	1505836100			PUSH ROD,FUEL INJECTION NOZZLE HOLDER L=36.67	CC					0105-1		
	1505836200			PUSH ROD,FUEL INJECTION NOZZLE HOLDER L=36.68	CC					0105-1		

インジェクションパイプ & ノズル
13 -410 INJECTION PIPE & NOZZLE

01 6D240 CTJS07000

-85-

見出番号 REF.-NO.	部品番号 PART NO.	代 替 順 号 R / P	記 号 S C E N E Q G	部品名称および記事・仕様記号 PART NAME & DESCRIPTION	型式・個数 MODEL & QTY				適用号機 APPLICABLE SERIAL NO.	管 区 M / R	新 規 V R D
					0	1			FROM@-@UPTO		
	1505836300			PUSH ROD,FUEL INJECTION NOZZLE HOLDER L=36.69	CC				0105-1		
	1505836400			PUSH ROD,FUEL INJECTION NOZZLE HOLDER L=36.70	CC				0105-1		
	1505836500			PUSH ROD,FUEL INJECTION NOZZLE HOLDER L=36.71	CC				0105-1		
	1505836600			PUSH ROD,FUEL INJECTION NOZZLE HOLDER L=36.72	CC				0105-1		
	1505836700			PUSH ROD,FUEL INJECTION NOZZLE HOLDER L=36.73	CC				0105-1		
	1505836800			PUSH ROD,FUEL INJECTION NOZZLE HOLDER L=36.74	CC				0105-1		
	1505836900			PUSH ROD,FUEL INJECTION NOZZLE HOLDER L=36.75	CC				0105-1		
	1505837000			PUSH ROD,FUEL INJECTION NOZZLE HOLDER L=36.76	CC				0105-1		
	1505837100			PUSH ROD,FUEL INJECTION NOZZLE HOLDER L=36.77	CC				0105-1		
	1505837200			PUSH ROD,FUEL INJECTION NOZZLE HOLDER L=36.78	CC				0105-1		
	1505837300			PUSH ROD,FUEL INJECTION NOZZLE HOLDER L=36.79	CC				0105-1		
	1505837400			PUSH ROD,FUEL INJECTION NOZZLE HOLDER L=36.80	CC				0105-1		
	1505837500			PUSH ROD,FUEL INJECTION NOZZLE HOLDER L=36.81	CC				0105-1		
	1505837600			PUSH ROD,FUEL INJECTION NOZZLE HOLDER L=36.82	CC				0105-1		
	1505837700			PUSH ROD,FUEL INJECTION NOZZLE HOLDER L=36.83	CC				0105-1		
	1505837800			PUSH ROD,FUEL INJECTION NOZZLE HOLDER L=36.84	CC				0105-1		
	1505837900			PUSH ROD,FUEL INJECTION NOZZLE HOLDER L=36.85	CC				0105-1		
	1505838000			PUSH ROD,FUEL INJECTION NOZZLE HOLDER L=36.86	CC				0105-1		
	1505838100			PUSH ROD,FUEL INJECTION NOZZLE HOLDER L=36.87	CC				0105-1		
	1505838200			PUSH ROD,FUEL INJECTION NOZZLE HOLDER L=36.88	CC				0105-1		
	1505838300			PUSH ROD,FUEL INJECTION NOZZLE HOLDER L=36.89	CC				0105-1		
	1505838400			PUSH ROD,FUEL INJECTION NOZZLE HOLDER L=36.90	CC				0105-1		
	1505838500			PUSH ROD,FUEL INJECTION NOZZLE HOLDER L=36.91	CC				0105-1		
	1505838600			PUSH ROD,FUEL INJECTION NOZZLE HOLDER L=36.92	CC				0105-1		
	1505838700			PUSH ROD,FUEL INJECTION NOZZLE HOLDER L=36.93	CC				0105-1		

インジェクションパイプ & ノズル
13-410 INJECTION PIPE & NOZZLE

-86-

01 6D240 CTJS07000

見出番号 REF.-NO.	部品番号 PART NO.	代 替 順 号 R / P	記 号 S C E N E Q G	部品名称および記事・仕様記号 PART NAME & DESCRIPTION	型式・個数 MODEL & QTY				適用号機 APPLICABLE SERIAL NO.	管 区 M / R	新 規 V R D	
					0	1			FROM@- : @UPTO			
07433B	1505838800			PUSH ROD,FUEL INJECTION NOZZLE HOLDER L=36.94	CC				0105-1			
	1505838900			PUSH ROD,FUEL INJECTION NOZZLE HOLDER L=36.95	CC				0105-1			
	1505900600			SHIM,FUEL INJECTION NOZZLE T=0.400	CC				0105-1			
	1505900700			SHIM,FUEL INJECTION NOZZLE T=0.500	CC				0105-1			
	1505900800			SHIM,FUEL INJECTION NOZZLE T=0.520	CC				0105-1			
	1505900900			SHIM,FUEL INJECTION NOZZLE T=0.540	CC				0105-1			
	1505901000			SHIM,FUEL INJECTION NOZZLE T=0.560	CC				0105-1			
	1505901100			SHIM,FUEL INJECTION NOZZLE T=0.580	CC				0105-1			
	1505901200			SHIM,FUEL INJECTION NOZZLE T=0.600	CC				0105-1			
	1505901300			SHIM,FUEL INJECTION NOZZLE T=0.700	CC				0105-1			
07433C	1505390700			SHIM,FUEL INJECTION NOZZLE T=0.400	CC				0105-1			
	1505390800			SHIM,FUEL INJECTION NOZZLE T=0.500	CC				0105-1			
	1505390900			SHIM,FUEL INJECTION NOZZLE T=0.520	CC				0105-1			
	1505391000			SHIM,FUEL INJECTION NOZZLE T=0.540	CC				0105-1			
	1505391100			SHIM,FUEL INJECTION NOZZLE T=0.560	CC				0105-1			
	1505391200			SHIM,FUEL INJECTION NOZZLE T=0.580	CC				0105-1			
	1505391300			SHIM,FUEL INJECTION NOZZLE T=0.600	CC				0105-1			
	1505391400			SHIM,FUEL INJECTION NOZZLE T=0.700	CC				0105-1			
	07434B	1505626600			SPRING,FUEL INJECTION NOZZLE HOLDER	6				0105-1		
	07434C	1505626500			SPRING,FUEL INJECTION NOZZLE HOLDER	6				0105-1		
07486F	1506241800			SPACER,FUEL INJECTION NOZZLE	6				0105-1			
07491B	1505251700 (1505251701)	3		PIN,FUEL INJECTION NOZZLE	12				0105-1			
07493B	1506515400			NUT,FUEL INJECTION NOZZLE	6				0105-1			
07494	MH000657			BOLT,FUEL INJECTION NOZZLE FLANGE,8X56	12				0105-1			
07495	ME930001			STAY,FUEL INJECTION TUBE	1				0105-1	0405-3		
07495H	ME355495			STAY,FUEL INJECTION TUBE	1				0406-1			
07497B	MF434103			NUT,FUEL INJECTION TUBE FLANGE,6	1				0406-1			
07498F	MH020293			CLAMP,FUEL INJECTION TUBE D=6X2	11				0105-1			

13 -420 FUEL RETURN HOSE
71-IL リターンホース

-88-

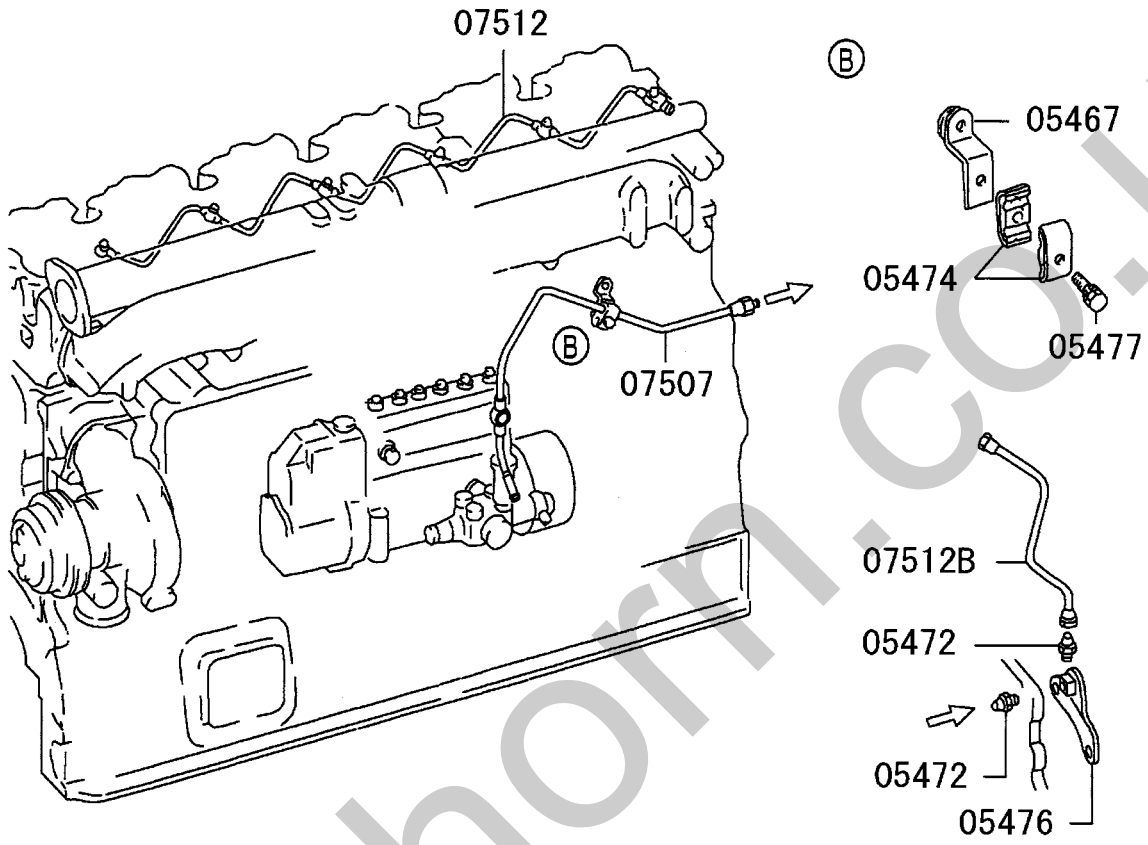

213T01

14 -110 WATER PUMP & FAN
 ウォータポンプ & ファン

-90-

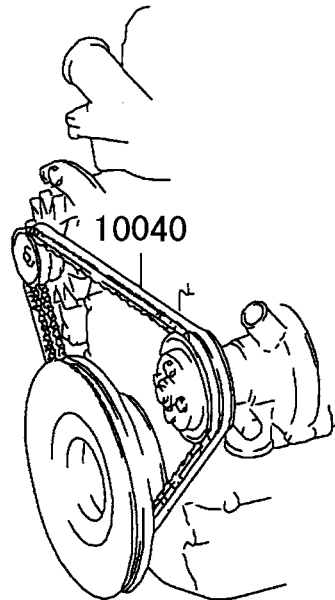
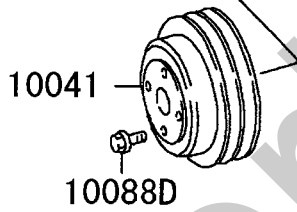
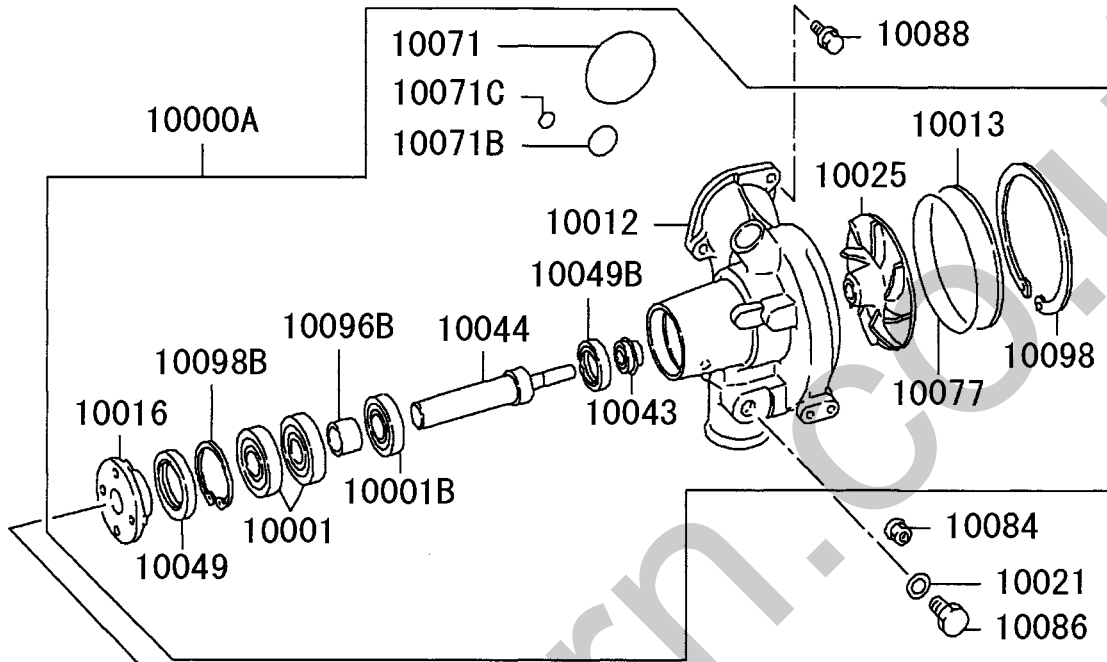

10010

- PNC
 10001, 10001B, 10025, 10043
 10044, 10049, 10049B, 10071
 10071B, 10071C, 10077

213T01

14-110 WATER PUMP & FAN

01 6D240 CTJS07000

-91-

見出番号 REF.-NO.	部品番号 PART NO.	代 替 R / P	記 順 号 S C E N E P Q G	部品名称および記事・仕様記号 PART NAME & DESCRIPTION	型式・個数 MODEL & QTY					適用号機 APPLICABLE SERIAL NO.	管 区 M / R	新 規 V R D	
					0	1							FROM@- : @UPTO
10000A	ME995231			WATER PUMP ASSY	1						0105-1		
10001	F801006305			BEARING,WATER PUMP BALL	2						0105-1		
10001B	F800606205			BEARING,WATER PUMP BALL	1						0105-1		
10010	ME995285 (ME995572)	3		WATER PUMP KIT	1						0105-1		
10012	ME157053			CASE,WATER PUMP	1						0105-1		
10013	ME055147			COVER,WATER PUMP	1						0105-1		
10016	ME055392			FLANGE,WATER PUMP PULLEY DRIVE	1						0105-1		
10021	F420216000			GASKET,WATER PUMP D=16	1						0105-1		
10025	ME055398			IMPELLER,WATER PUMP	1						0105-1		
10040	ME900715	3		BELT,ALTERNATOR & OTHERS 1695X2	1						0105-1		
10041	(MH014510) ME055315			PULLEY,WATER PUMP	1						0105-1		
10043	ME241056	#		SEAL UNIT,WATER PUMP SHAFT C07554	1						0105-1		
10044	ME158685			SHAFT,WATER PUMP	1						0105-1		
10049	ME150299			OIL SEAL,WATER PUMP SHAFT	1						0105-1		
10049B	ME055395			OIL SEAL,WATER PUMP SHAFT	1						0105-1		
10071	MH035619			O-RING,WATER PUMP D=75	1						0105-1		
10071B	MH035622			O-RING,WATER PUMP D=29	1						0105-1		
10071C	MH035092			O-RING,WATER PUMP D=14	1						0105-1		
10077	MH035620			O-RING,WATER PUMP INR D=125	1						0105-1		
10084	MF434105			NUT,WATER PUMP FLANGE,10	2						0105-1		
10086	M0001300	3		PLUG,WATER PUMP SCREW,D=16	1						0105-1		
10088	(MB001260) MH000714			BOLT,WATER PUMP FLANGE,10X25	2						0105-1		
10088D	MH000706			BOLT,WATER PUMP FLANGE,10X16	4						0105-1		
10096B	ME055396			SPACER,WATER PUMP INR T=20	1						0105-1		
10098	ME055149			SNAP RING,WATER PUMP INR	1						0105-1		
10098B	F320206200			SNAP RING,WATER PUMP INR D=62	1						0105-1		

ウォーターパイプ & サーマスタット
14 -120 WATER PIPE & THERMOSTAT

-92-

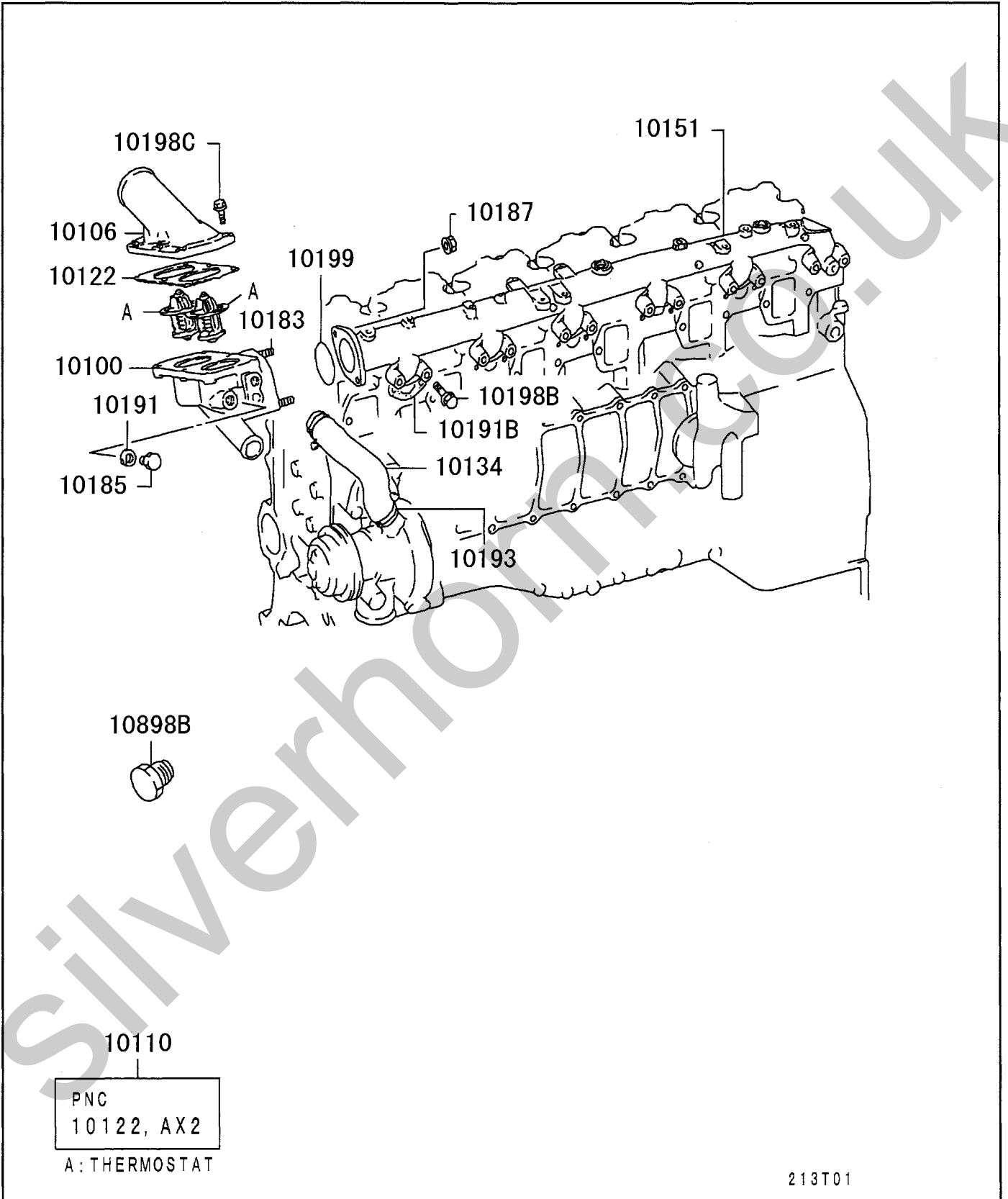

ウォーターパイプ & サーマスタット
14 -120 WATER PIPE & THERMOSTAT

01 6D240 CTJS07000

-93-

見出番号 REF.-NO.	部品番号 PART NO.	代 替 R / P	変 記 順 号 S C E N E Q G	部品名称および記事・仕様記号 PART NAME & DESCRIPTION	型式・個数 MODEL & QTY				適用号機	管 区 M / R	新 規 V / R D
					0	1			APPLICABLE SERIAL NO.		
10100	ME059413			CASE,THERMOSTAT	1				0105-1		
10106	ME059420			COVER,THERMOSTAT CASE	1				0105-1		
10110	ME996003			THERMOSTAT KIT 76.5°CX2	1				0105-1		
10122	ME120978			GASKET,THERMOSTAT COVER	1				0105-1		
10134	ME059271			HOSE,THERMOSTAT WATER BY-PASS	1				0105-1		
10151	ME150883			PIPE,COOLING WATER OUTLET	1				0105-1		
10183	MF406285			STUD,COOLING WATER LINE 10X22	2				0105-1		
10185	M0001300	3		PLUG,COOLING WATER LINE SCREW,D=16	1				0105-1		
10187	(MB001260) MF434105			NUT,COOLING WATER LINE FLANGE,10	2				0105-1		
10191	F420216000			GASKET,COOLING WATER LINE D=16	1				0105-1		
10191B	ME150855			GASKET,COOLING WATER LINE	6				0105-1		
10193	MH021375			CLIP,COOLING WATER LINE D=32-50	2				0105-1		
10198B	MH000708			BOLT,COOLING WATER LINE FLANGE,10X45	12				0105-1	0208-3	
	MS146014			BOLT,COOLING WATER LINE FLANGE,10X45	12				0209-1		
10198C	MS146006			BOLT,COOLING WATER LINE FLANGE,10X25	6				0105-1		
10199	MH035618			O-RING,COOLING WATER LINE D=65	1				0105-1		
10898B	3124618702			PLUG,WATER TEMPERATURE GAUGE 16X17	2				0105-1		

インレット マニホールド
15 -210 INLET MANIFOLD

-94-

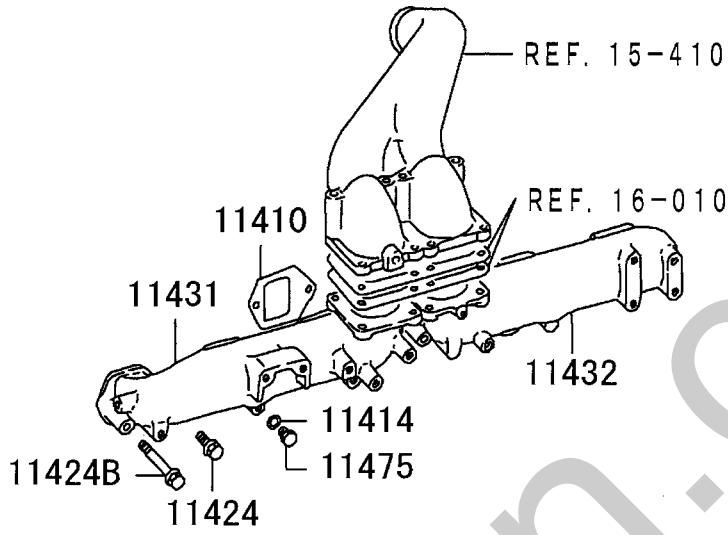

Silverhorn.CO.UK

エキゾーストマニホールド
15-310 EXHAUST MANIFOLD

-96-

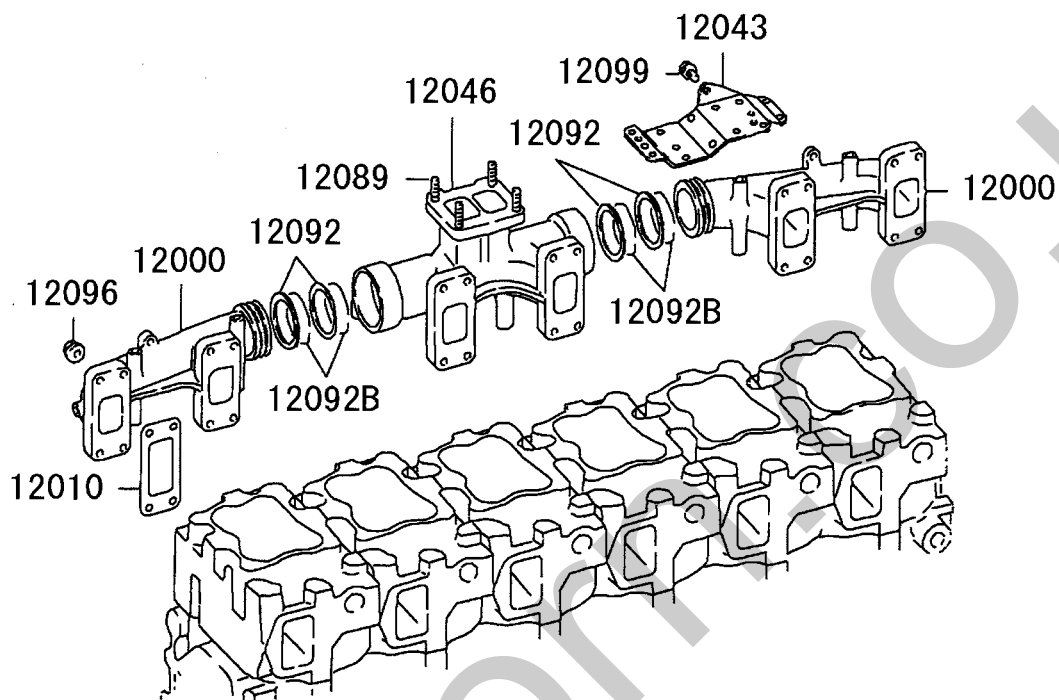

213T01

15 -310 EXHAUST MANIFOLD

イキゾ-ストマニホールド

01 6D240 CTJS07000

-97-

見出番号 REF.-NO.	部品番号 PART NO.	代 替 R / P 記 順 号 S C / E N / Q G	部品名称および記事・仕様記号 PART NAME & DESCRIPTION	型式・個数 MODEL & QTY					適用号機 APPLICABLE SERIAL NO.	管 区 M / R 新 規 V / R D
				0	1					
12000	ME152481		MANIFOLD,EXHAUST	2					0105-1	
12010	ME053112		GASKET,EXHAUST MANIFOLD	6					0105-1	
12043	ME150073		INSULATOR,EXHAUST MANIFOLD HEAT	1					0105-1	
12046	ME053862		MANIFOLD,EXHAUST,CTR	1					0105-1	
12089	MF407728		STUD,EXHAUST MANIFOLD	4					0105-1	0302-3
	MH002154		STUD,EXHAUST MANIFOLD 10X30	4					0303-1	
12092	ME053950		SEAL RING,EXHAUST MANIFOLD	4					0105-1	
12092B	ME053952		SEAL RING,EXHAUST MANIFOLD	4					0105-1	
12096	MH004054		NUT,EXHAUST MANIFOLD SELF LOCKING,FLANGE,10	24					0105-1	
12099	MH000392		BOLT,EXHAUST MANIFOLD WASHER ASSEMBLED,8X12	3					0105-1	

ターボチャージャー
15-410 TURBOCHARGER

-98-

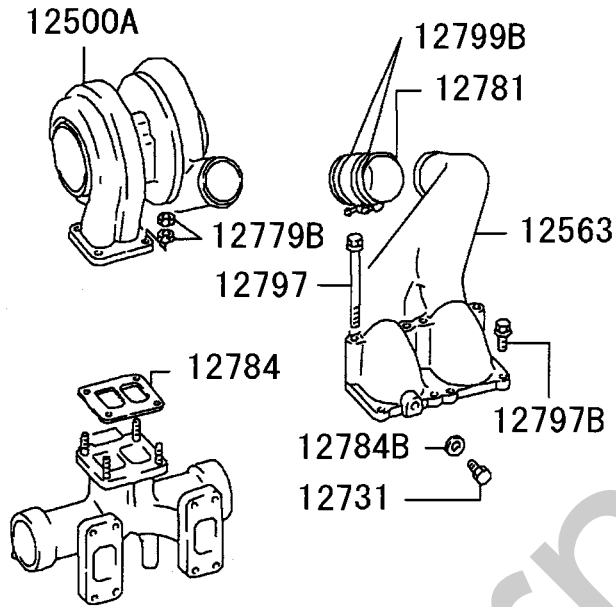

213T01

INNER PARTS

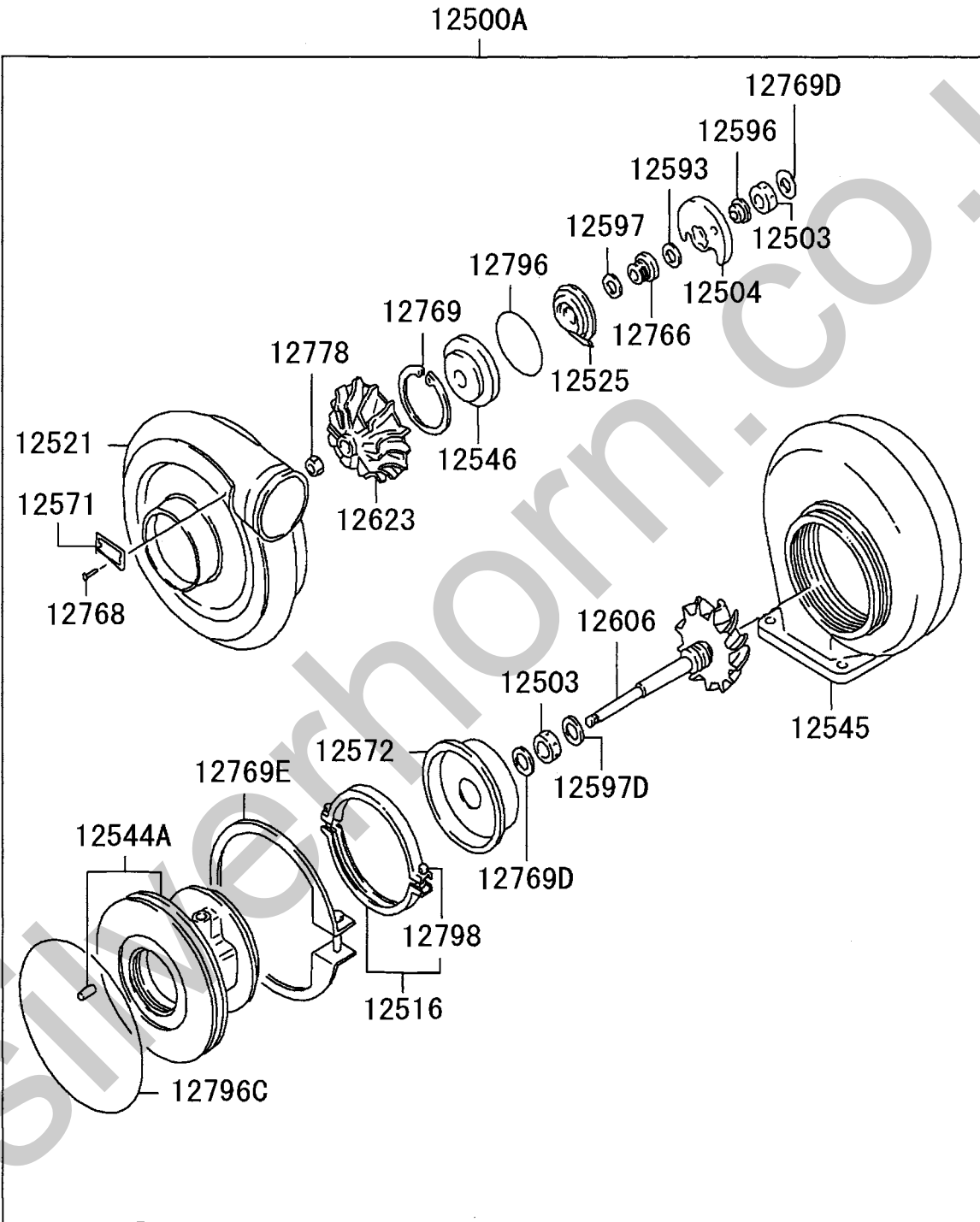

ターボチャージャー
15-410 TURBOCHARGER

-100-

01 6D240 CTJS07000

見出番号 REF.-NO.	部品番号 PART NO.	代 替 順 号 R / S C E N G P Q G	部品名称および記事・仕様記号 PART NAME & DESCRIPTION	型式・個数 MODEL & QTY					適用号機 APPLICABLE SERIAL NO.	管 区 M / R	新 規 V R D
				0	1				FROM@- : @UPTO		
12500A	4918801661		TURBOCHARGER ASSY TD08	1					0105-1		
12503	4917421100 (4917421110)	3	BEARING, T/C SHAFT	2					0105-1		
12504	4918821500		THRUST BEARING, T/C	1					0105-1		
12516	4917414000		COUPLING, T/C HOUSING	1					0105-1		
12521	4918855120		COVER, T/C COMPRESSOR	1					0105-1		
12525	4918822210		DEFLECTOR, T/C OIL	1					0105-1		
12544A	4918825300		HOUSING ASSY, T/C BEARING	1					0105-1		
12545	4918810400		HOUSING, T/C TURBINE	1					0105-1		
12546	4918822500		INSERT, T/C BEARING HOUSING	1					0105-1		
12563	ME050759		PIPE, T/C TO INLET MANIFOLD	1					0105-1		
12571	4916855200		NAME PLATE, T/C	1					0105-1		
12572	4918819100		PLATE, T/C TURBINE BACK	1					0105-1		
12593	4918842300		RING, T/C SHAFT BEARING THRUST	1					0105-1		
12596	4918842400		RING, T/C SHAFT THRUST	1					0105-1		
12597	4917423100		RING, T/C SHAFT TURBINE PISTON	1					0105-1		
12597D	4918123100		RING, T/C SHAFT TURBINE PISTON	1					0105-1		
12606	4918830100	#	SHAFT & TURBINE, T/C T97020	1					0105-1	0610-2	
	4918830130		SHAFT & TURBINE, T/C LH-THREAD	1					0610-3		V
12623	4918845120		WHEEL, T/C COMPRESSOR	1					0105-1		
12731	ME031088		PLUG, T/C SCREW	1					0105-1		
12766	4918842100		SLEEVE, T/C INR	1					0105-1		
12768	0066502048		RIVET, T/C INR	1					0105-1		
12769	4917423200		SNAP RING, T/C INR	1					0105-1		
12769D	4917422300		SNAP RING, T/C INR	2					0105-1		
12769E	4917423300		SNAP RING, T/C INR	1					0105-1		
12778	4917442200		NUT, T/C INR	1					0105-1	0610-2	
	4913442200		NUT, T/C INR LH-THREAD	1					0610-3		V
12779B	MH004110		NUT, T/C 10	8					0105-1		
12781	ME053870		HOSE, T/C 63.5X65	1					0105-1		
12784	ME150877		GASKET, T/C	1					0105-1		
12784B	F420210000		GASKET, T/C D=10	1					0105-1		
12796	4917422600		O-RING, T/C INR	1					0105-1		
12796C	4917422700		O-RING, T/C INR	1					0105-1		
12797	MH000829		BOLT, T/C FLANGE, 10X120	4					0105-1		
12797B	MH000716		BOLT, T/C FLANGE, 10X55	4					0105-1		
12798	4916814020		BOLT, T/C INR	1					0105-1		
12799B	MH021370		CLAMP, T/C D=60-80	2					0105-1		

16-010 STARTER

-102-

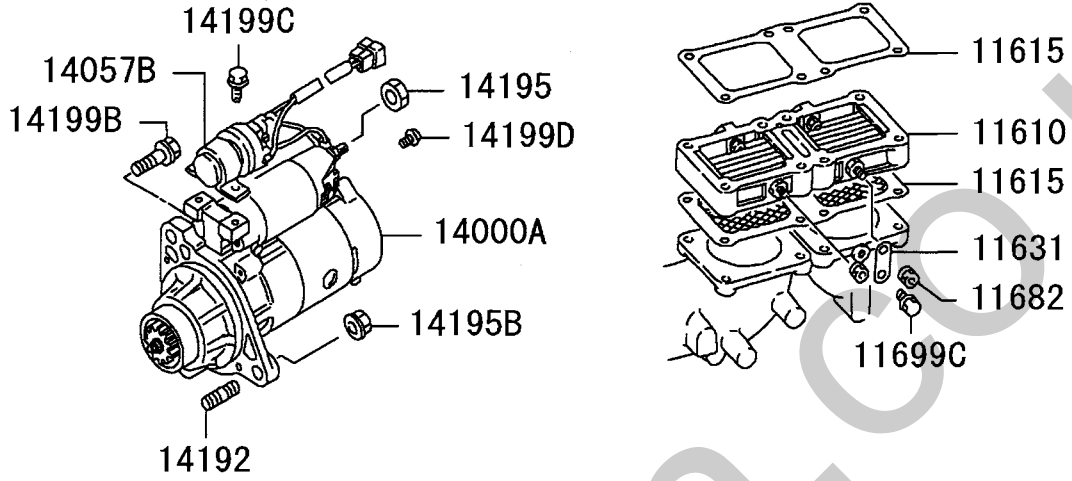

213T01

INNER PARTS

14000A

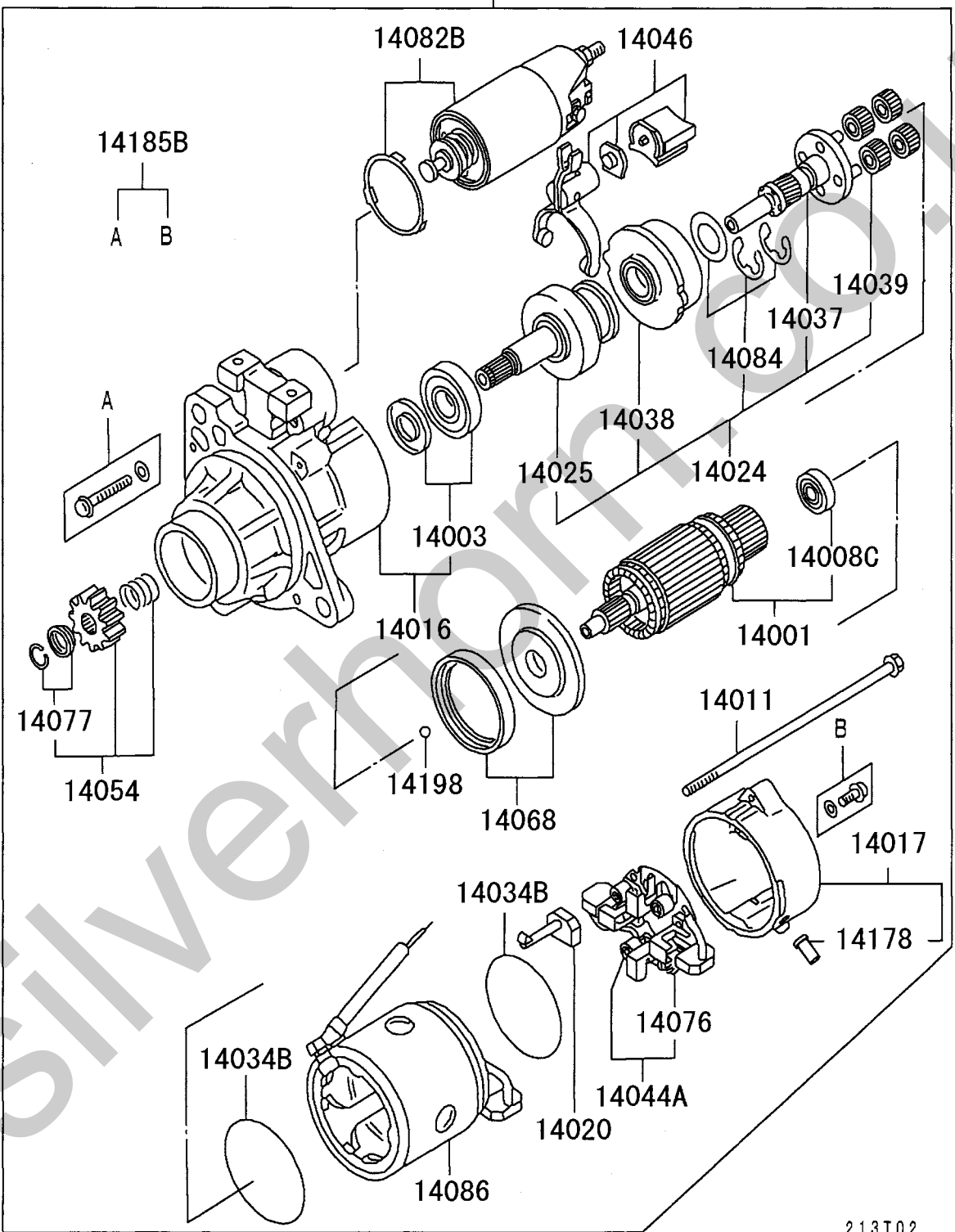

213T02

16-010 STARTER

-104-

01 6D240 CTJS07000

見出番号 REF.-NO.	部品番号 PART NO.	代 替 R / P	記 順 号 S C E N / Q G	部品名称および記事・仕様記号 PART NAME & DESCRIPTION	型式・個数 MODEL & QTY					適用号機 APPLICABLE SERIAL NO.	管 区 M / R	新 規 V R D	
					0	1							FROM@- :@UPTO
11610	ME067539			HEATER,INTAKE AIR	1						0105-1		
11615	ME150067			GASKET,INTAKE AIR HEATER	1						0105-1		
	ME150878			GASKET,INTAKE AIR HEATER W/NET	1						0105-1		
11631	ME057329			PLATE,INTAKE AIR HEATER CABLE EARTH	1						0105-1		
11682	MF434103			NUT,INTAKE SILENCER FLANGE,6	2						0105-1		
11699C	MF140020			BOLT,INTAKE AIR HEATER FLANGE,8X10	1						0105-1		
14000A	M009T60171			STARTER ASSY 24V-5.5KW	1						0105-1		
14001	M106X44372			ARMATURE KIT,STARTER	1						0105-1		
14003	M690X00871			BEARING & SLEEVE KIT,STARTER	1						0105-1		
14008C	M931X01270			BEARING,STARTER ARMATURE	1						0105-1		
14011	M981X76071			BOLT SET,STARTER	1						0105-1		
14016	M641X83471			BRACKET,STARTER,FR	1						0105-1		
14017	M642X48171			BRACKET,STARTER,RR	1						0105-1		
14020	M648X42171			BRUSH,STARTER	2						0105-1		
14024	M357X92871			CLUTCH KIT,STARTER PINION & REDUCTION	1						0105-1		
14025	M191X69571			CLUTCH,STARTER OVERRUNNING	1						0105-1		
14034B	M578X31071			GASKET,STARTER INR	2						0105-1		
14037	M357X67871			GEAR,STARTER REDUCTION	1						0105-1		
14038	M135X02771			GEAR,STARTER REDUCTION INTERNAL	1						0105-1		
14039	M230X00971			GEAR,STARTER REDUCTION PINION	4						0105-1		
14044A	M649X21471			HOLDER ASSY,STARTER BRUSH	1						0105-1		
14046	M863X09274			LEVER KIT,STARTER PINION SHIFT	1						0105-1		
14054	M605X98871 (M605X77571) M605X77571	3		PINION KIT,STARTER PINION KIT,STARTER	1 1						0105-1 0210-3		
14057B	ME049300			RELAY,STARTER SAFETY CONTROL	1						0105-1		
14068	M578X30971			GASKET SET,STARTER YOKE	1						0105-1		
14076	M391X04571			SPRING,STARTER BRUSH	4						0105-1		
14077	M385X06771			STOPPER KIT,STARTER PINION	1						0105-1		
14082B	M371XB3271			SWITCH KIT,STARTER MAGNETIC	1						0105-1		V
14084	M982X38871			WASHER SET,STARTER GEAR SHAFT	1						0105-1		
14086	M800X74071			YOKE,STARTER	1						0105-1		
14178	M256X08471			GROMMET,STARTER INR	1						0105-1		
14185B	M414X07472			SCREW,STARTER INR	1						0105-1		
14192	F145012035			STUD,STARTER 12X35	1						0105-1		
14195	MH004186			NUT,STARTER 10	1						0105-1		
14195B	MF434106			NUT,STARTER FLANGE,12	1						0105-1		
14198	S409S00008			BALL,STARTER INR	1						0105-1		
14199B	MH000924 (MH000840)	R		BOLT,STARTER FLANGE,12X40	2						0105-1		
14199C	MH000999			BOLT,STARTER FLANGE,6X12	2						0105-1		

16 -110 ALTERNATOR & REGULATOR

-106-

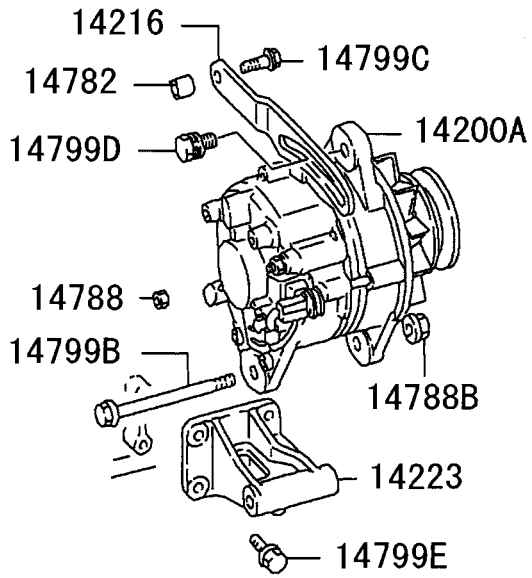

Silverhorn.CO.UK

INNER PARTS

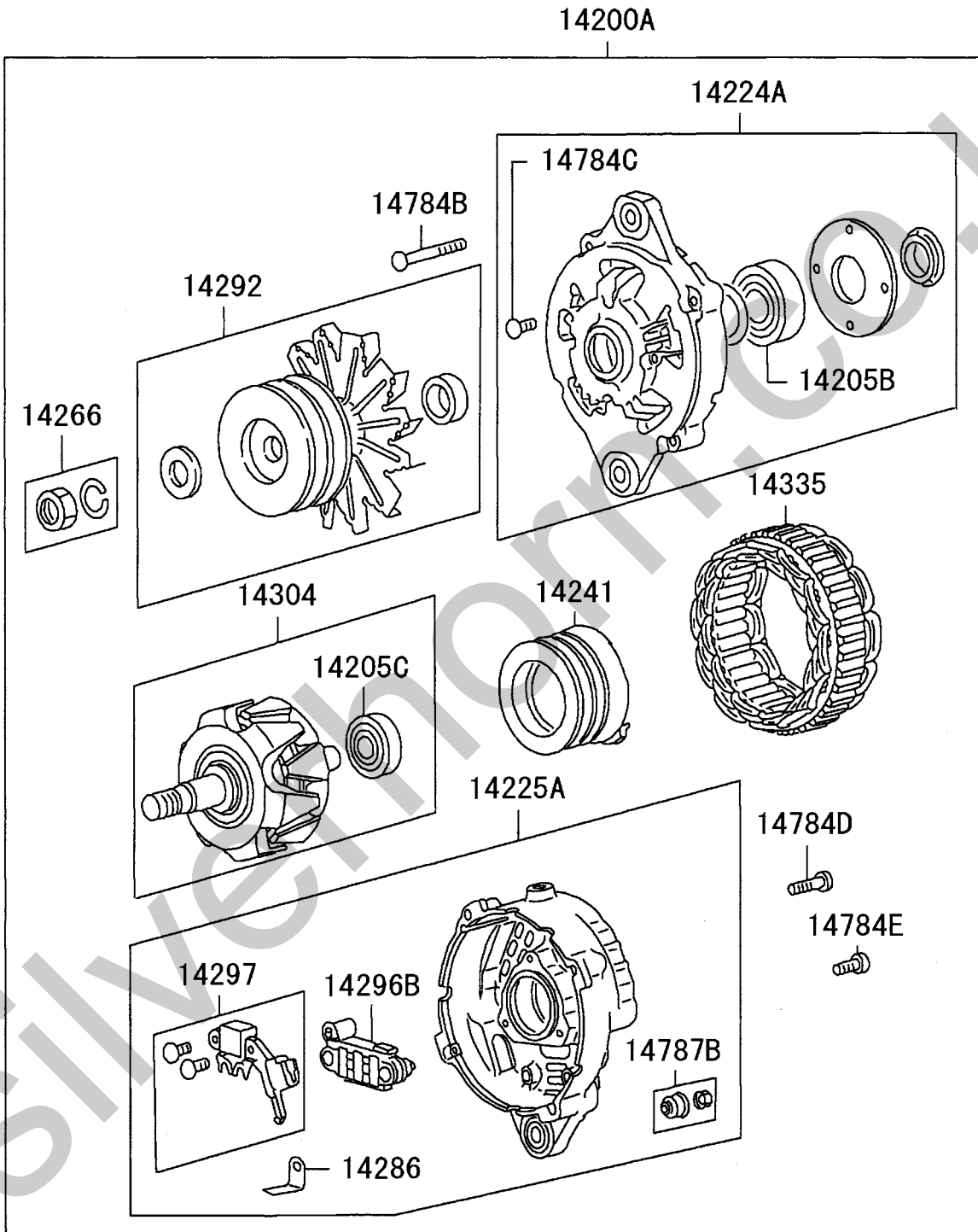

16 -110 ALTERNATOR & REGULATOR

オルタネータ&レギュレータ

-108-

01 6D240 CTJS07000

見出番号 REF.-NO.	部品番号 PART NO.	代 替 R / P	委 記 順 号 S C E N Q G	部品名称および記事・仕様記号 PART NAME & DESCRIPTION	型式・個数 MODEL & QTY				適用号機 APPLICABLE SERIAL NO.		管 区 M / R	新 規 V / R D
					0	1			FROM@-	@UPTO		
14200A	A004T40386			ALTERNATOR ASSY 24V-50A	1				0105-1	0501-2		
	A004TU7686			ALTERNATOR ASSY 24V-50A	1				0501-3			
14205B	S930P90670			BEARING,ALTERNATOR ROTOR	1				0105-1			
14205C	S930P81170			BEARING,ALTERNATOR ROTOR	1				0105-1			
14216	ME057675			BRACE,ALTERNATOR ADJUSTING	1				0105-1			
14223	ME057862			BRACKET,ALTERNATOR MOUNTING	1				0105-1			
14224A	A640X57570			BRACKET ASSY,ALTERNATOR,FR	1				0105-1			
14225A	A642X22770			BRACKET ASSY,ALTERNATOR,RR	1				0105-1	0501-2		
	A642XE2370			BRACKET ASSY,ALTERNATOR,RR	1				0501-3			
14241	A299X01470			COIL,ALTERNATOR ROTOR	1				0105-1			
14266	A529X06571	3		NUT KIT,ALTERNATOR PULLEY W/WASHER	1				0105-1	0207-3		
	(A981X21071)											
	A981X21071			NUT KIT,ALTERNATOR PULLEY FLANGE	1				0208-1			
14286	A666X82870			PLATE,ALTERNATOR RR BRACKET	1				0105-1			
14292	A628T54470			PULLEY & FAN KIT,ALTERNATOR	1				0105-1			
14296B	A860X47970			RECTIFIER,ALTERNATOR	1				0105-1	0501-2		
	A860X91970			RECTIFIER,ALTERNATOR	1				0501-3			
14297	A866X38272			REGULATOR,ALTERNATOR	1				0105-1			
14304	A880X69170			ROTOR KIT,ALTERNATOR	1				0105-1			
14335	A383X37370			STATOR,ALTERNATOR	1				0105-1			
14782	3013302300			SPACER,ALTERNATOR	1				0105-1			
				8								
14784B	A414X19971			SCREW,ALTERNATOR INR	1				0105-1			V
14784C	A414X20071			SCREW,ALTERNATOR INR	1				0105-1			
14784D	A414X21571			SCREW,ALTERNATOR INR	1				0105-1			
14784E	A414X23371			SCREW,ALTERNATOR INR	1				0105-1			
14787B	A529X08971	3		NUT,ALTERNATOR INR	1				0105-1	0110-3		
	(A529X12671)											
	A529X12671			NUT,ALTERNATOR INR	1				0111-1			
14788	MS446183			NUT,ALTERNATOR FLANGE,8	1				0105-1			
14788B	MF434106			NUT,ALTERNATOR FLANGE,12	1				0105-1			
14799B	MH000703			BOLT,ALTERNATOR FLANGE,12X125	1				0105-1			
14799C	MH000714			BOLT,ALTERNATOR FLANGE,10X25	1				0105-1			
14799D	MH000372			BOLT,ALTERNATOR WASHER ASSEMBLED,12X30	1				0105-1			
14799E	MH000713	#		BOLT,ALTERNATOR FLANGE,10X20 T02406A	4				0105-1	0312-3		
	MS146005			BOLT,ALTERNATOR FLANGE,10X22	4				0401-1			

パワーステアリング オイルポンプ
37 -110 POWER STEERING OIL PUMP

-110-

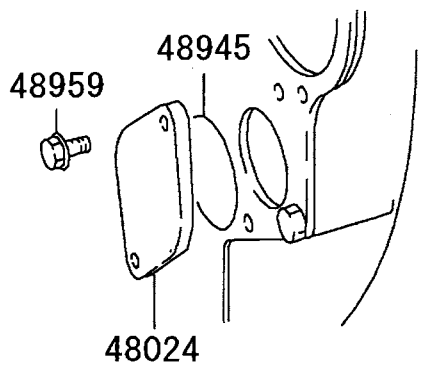

Silverhorn.CO.UK

01911C

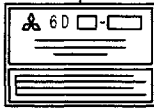

Silverhorn.CO.UK

部 品 番 号 顺 索 引

PARTS NUMBER INDEX

Silverhorn.CO.UK

Silverhorn.CO.UK

部 品 番 号 順 索 引
PARTS NUMBER INDEX

A1

部品番号 PART NO.	ページ PAGE	見出番号 REF.NO.	部品番号 PART NO.	ページ PAGE	見出番号 REF.NO.	部品番号 PART NO.	ページ PAGE	見出番号 REF.NO.
A004T40386	108	14200A	M0001300	93	10185	ME051672	20	01396B
A004TU7686	108	14200A	M009T60171	104	14000A	ME051673	20	01396C
A299X01470	108	14241	M106X44372	104	14001	ME051674	20	01396D
A383X37370	108	14335	M135X02771	104	14038	ME051675	20	01396E
A414X19971	108	14784B	M191X69571	104	14025	ME051676	20	01396F
A414X20071	108	14784C	M230X00971	104	14039	ME051677	20	01396G
A414X21571	108	14784D	M256X08471	104	14178	ME051678	20	01396H
A414X23371	108	14784E	M357X67871	104	14037	ME051694	15	01100
A529X06571	108	14266	M357X92871	104	14024	ME051696	33	03410
A529X08971	108	14787B	M371XB3271	104	14082B	ME051697	33	03420
A529X12671	108	14787B	M385X06771	104	14077	ME051698	33	03410
A628T54470	108	14292	M391X04571	104	14076	ME051705	15	01182
A640X57570	108	14224A	M414X07472	104	14185B	ME051714	17	01210
A642X22770	108	14225A	M578X30971	104	14068	ME052149	29	03036
A642XE2370	108	14225A	M578X31071	104	14034B	ME052661	26	02122
A666X82870	108	14286	M605X77571	104	14054	ME052691	27	03797
A860X47970	108	14296B	M605X98871	104	14054	ME052765	29	03006
A860X91970	108	14296B	M641X83471	104	14016	ME052843	35	03107C
A866X38272	108	14297	M642X48171	104	14017	ME052916	35	03118
A880X69170	108	14304	M648X42171	104	14020	ME053112	97	12010
A981X21071	108	14266	M649X21471	104	14044A	ME053862	97	12046
F102506025	26	02192C	M690X00871	104	14003	ME053870	100	12781
F145010030	19	01383	M800X74071	104	14086	ME053950	97	12092
F145012035	104	14192	M863X09274	104	14046	ME053952	97	12092B
F160005010	105	14199D	M931X01270	104	14008C	ME054082	51	04127C
F230006000	26	02188	M981X76071	104	14011	ME054156	51	04127B
F230510000	33	03299	M982X38871	104	14084	ME054279	56	12543
F230516000	35	03296B	MB001260	26	02185D	ME054385	15	01303
F250008000	26	02178C		91	10086	ME054661	51	04101
F251506000	26	02178		93	10185	ME054744	46	01399E
F251508000	73	07277M	MD000523	15	01134		56	12537
F251510000	41	15172D	MD008784	23	04903A	ME055147	91	10013
F287005019	33	03196	ME014717	53	04385	ME055149	91	10098
	35	03297	ME016894	59	05392	ME055315	91	10041
F315307500	111	48945	ME031088	19	01385K	ME055392	91	10016
F315603500	35	03295B		95	11475	ME055395	91	10049B
F315604500	15	01983		100	12731	ME055396	91	10096B
F320206200	27	03795	ME032042	29	03031	ME055398	91	10025
	91	10098B	ME040252	46	02200B	ME056279	59	05314
F420210000	20	01399M	ME049300	104	14057B	ME056381	61	07011
	51	04184B	ME050759	100	12563	ME056670	59	05300
	56	04998C	ME051003	46	01307C	ME056925	89	07512
	95	11414	ME051051	33	03323	ME057119	40	15026A
	100	12784B	ME051083	33	03412	ME057309	111	48024
F420214000	41	15189B	ME051120	17	03460	ME057329	104	11631
F420216000	26	02116	ME051122	17	03470	ME057332	40	15054B
	41	15189C	ME051180	33	03316	ME057675	108	14216
	91	10021	ME051208	33	03417	ME057862	108	14223
	93	10191	ME051241	46	01307K	ME058316	29	03047
F420220000	51	04192	ME051300	17	03411	ME058900	23	04905
F420227000	41	15189D	ME051344	46	01307D	ME058983	56	12621B
	46	01399C	ME051354	17	03407	ME058989	15	01951
	56	04998B	ME051373	15	01127	ME059271	93	10134
F430003201	15	01988	ME051515	17	01298B	ME059413	93	10100
F461016000	42	15197E	ME051516	17	01298C	ME059420	93	10106
F501428000	19	01395J	ME051584	33	03266B	ME059630	89	07512B
F800606205	91	10001B	ME051587	17	03411	ME060124	46	01361
F801006305	91	10001	ME051632	19	01342	ME060125	46	03033
M0001300	26	02185D	ME051633	19	01342	ME061021	33	03172
	91	10086	ME051634	19	01342	ME061398	33	03416

部 品 番 号 順 索 引
PARTS NUMBER INDEX

A2

部品番号 PART NO.	ページ PAGE	見出番号 REF.NO.	部品番号 PART NO.	ページ PAGE	見出番号 REF.NO.	部品番号 PART NO.	ページ PAGE	見出番号 REF.NO.
ME061699	26	02124	ME151299	33	03100	ME181339	29	03050
ME062326	35	03145	ME151300	33	03146	ME181340	29	03050
ME062523	17	01207B	ME151450	29	03016	ME181341	29	03050
ME062573	35	03271	ME151859	26	03030A	ME241056	91	10043
ME062828	26	03057	ME151865	49	04161D	ME350565	49	04007A
ME062905	35	03107B	ME151866	49	04161C	ME350786	29	03060
ME064526	53	04338	ME151877	49	04005	ME350787	29	03060
ME067539	104	11610	ME152008	33	03277B	ME350788	30	03060
ME074455	56	04232	ME152344	23	01510	ME350789	30	03060
ME084527	53	04353	ME152473	46	01326	ME350864	20	03040
ME090010	59	05300A	ME152481	97	12000	ME350865	20	03040
ME090012	59	05300A	ME152584	27	03080	ME350866	20	03040
ME093097	35	03026	ME152602	26	02100	ME350867	20	03040
ME093522	41	15183	ME153172	53	04322	ME350868	20	03040
ME095645	33	03405	ME153173	53	04346	ME351296	26	03057
ME120432	46	01307B	ME153215	19	01305	ME351447	49	04161B
ME120978	93	10122	ME153274	33	03440	ME351466	19	01385H
ME121284	49	04045	ME153301	46	01394B	ME351469	26	03034
ME121788	51	04140	ME153319	19	01388	ME351471	27	03083
ME121799	29	03022	ME157032	23	04912	ME351483	49	04161C
ME121800	51	04115	ME157053	91	10012	ME351484	20	01399K
ME133039	46	01306	ME157194	56	12548	ME351744	33	03266B
ME150048	26	02114	ME157205	40	15078	ME351837	27	03083
ME150051	95	11410	ME157230	56	12621	ME352391	27	03083
ME150056	46	01399	ME157250	95	11432	ME352719	30	03787
ME150057	46	01399B	ME158019	89	05476	ME355448	40	15000A
ME150058	46	02023	ME158066	56	04925C	ME355495	86	07495H
ME150060	23	04991B	ME158097	29	03037	ME357130	29	03010A
ME150067	104	11615	ME158098	29	03037	ME359097	29	03022
ME150073	97	12043	ME158099	29	03037	ME441099	40	15078
ME150236	40	15081	ME158100	29	03037	ME441102	40	15078B
ME150237	40	15076	ME158101	29	03037	ME713008	41	15184C
ME150299	91	10049	ME158102	29	03037	ME713009	41	15172B
ME150441	53	04311	ME158104	95	11431	ME713014	40	15033
ME150442	53	04377	ME158178	23	01500	ME713016	40	15051
ME150453	53	04300A	ME158181	23	04911	ME713017	41	15106
ME150482	19	01381	ME158183	59	05480N	ME713018	41	15121
ME150493	29	03010A	ME158184	59	05480M	ME713019	40	15097
ME150497	26	03030A	ME158221	82	07429	ME713020	40	15037
ME150506	35	03132A	ME158222	82	07429	ME713021	40	15105
ME150508	35	03298D	ME158223	82	07429	ME713022	41	15117
ME150509	35	03298E	ME158224	82	07429	ME713023	40	15096
ME150511	33	03302B	ME158225	82	07429	ME713024	40	15035
ME150519	35	03155B	ME158226	82	07429	ME713025	41	15183C
ME150520	35	03155C	ME158303	35	03129	ME713031	40	15014
ME150532	49	04124	ME158479	89	07507	ME713032	41	15114
ME150541	49	04161B	ME158685	91	10044	ME713033	41	15115
ME150600	40	15000A	ME159062	56	12617	ME713076	41	15172C
ME150601	49	04000A	ME160705	49	04042	ME713077	42	15198B
ME150639	49	04017	ME160708	49	04016	ME713078	40	15098C
ME150682	53	04334	ME160715	49	04033	ME713081	41	15172D
ME150689	35	03135A	ME162632	49	04035	ME713082	41	15184D
ME150849	29	03022	ME164716	51	04111B	ME713093	42	15198C
ME150855	93	10191B	ME164831	19	01305	ME713196	41	15191
ME150877	100	12784	ME165370	51	04130	ME713206	40	15043A
ME150878	104	11615	ME180041	20	01397N	ME713208	41	15174B
ME150883	93	10151	ME180513	51	04100A	ME713224	40	15047
ME151039	19	01388B	ME180514	51	04180	ME713226	40	15023
ME151267	26	02111	ME181337	29	03050	ME713266	40	15023
ME151298	35	03136	ME181338	29	03050	ME713327	40	15087

部 品 番 号 順 索 引
PARTS NUMBER INDEX

A3

部品番号 PART NO.	ページ PAGE	見出番号 REF.NO.	部品番号 PART NO.	ページ PAGE	見出番号 REF.NO.	部品番号 PART NO.	ページ PAGE	見出番号 REF.NO.
ME713329	40	15034	MF300850	49	04096	MH001103	15	01198
ME713337	41	15183F	MF300853	49	04178	MH001785	23	01597B
ME713361	40	15082	MF303363	23	01597B	MH002131	17	01282B
ME713384	42	15198B	MF303365	46	01397	MH002154	97	12089
ME713385	41	15179	MF406251	56	04972	MH004054	97	12096
ME713408	40	15073	MF406285	93	10183	MH004069	49	04079
ME713409	40	15095	MF407728	97	12089	MH004075	35	03296D
ME713466	40	15087	MF434103	56	04979	MH004110	100	12779B
ME737042	40	15045A		86	07497B	MH004186	104	14195
ME737118	40	15073		104	11682	MH007008	19	01387N
ME737130	41	15116	MF434105	91	10084	MH007009	19	01387M
ME737132	40	15024A		93	10187	MH007011	19	01387HC
ME737139	40	15031	MF434106	104	14195B	MH012026	30	03788B
ME737201	41	15184C		108	14788B	MH012037	19	01386M
ME737202	40	15074	MF472086	49	04078		35	03293B
ME737204	40	15073	MF472402	35	03294	MH014510	91	10040
ME737214	40	15045A	MF472404	19	01387K	MH020290	41	15194B
ME760102	40	15082	MF472405	19	01387H	MH020293	86	07498F
ME760103	40	15061		27	03796	MH020294	87	07498G
ME900715	91	10040	MF472406	19	01387J	MH020558	41	15194C
ME930001	56	04973C	MF472407	30	03788	MH021015	23	04993
	86	07495	MF472585	17	01288	MH021218	59	05494
ME930211	59	05482	MF476220	41	15186	MH021233	56	04994
ME993083	11	03000A	MF540021	49	04099		89	05474
ME993092	7	01300A	MF650106	42	15197B	MH021260	56	04994B
ME993287	13	01070	MH000372	108	14799D	MH021295	56	04992
ME993457	9	01340	MH000377	30	03787	MH021370	100	12799B
ME993459	3	01010A	MH000392	97	12099	MH021375	93	10193
ME993779	7	01300A	MH000657	86	07494	MH023119	89	05467
ME993816	11	03000A	MH000703	108	14799B	MH023799	23	04985
ME993820	3	01010A	MH000706	15	01978	MH035018	23	01521
ME994204	20	03040		42	15199D	MH035025	51	04182
ME994205	20	03040		59	05496P	MH035044	53	04379C
ME994206	20	03040		87	07499B	MH035067	59	05394F
ME994207	20	03040		91	10088D	MH035069	59	05394E
ME994208	20	03040	MH000708	93	10198B	MH035077	20	01399K
ME994419	29	03050	MH000713	42	15199C		20	01399N
ME994420	29	03050		46	01397B	MH035092	53	04379E
ME994421	29	03050		56	04997C		91	10071C
ME994422	29	03050		108	14799E	MH035093	53	04379
ME994423	29	03050	MH000714	33	03198	MH035129	56	04978
ME995231	91	10000A		59	05399	MH035135	33	03279
ME995285	91	10010		91	10088	MH035157	17	01291
ME995572	91	10010		95	11424	MH035190	41	15189E
ME996003	93	10110		108	14799C	MH035192	41	15189F
ME996916	5	01200A	MH000715	49	04098	MH035225	23	04999
ME996917	5	01200A	MH000716	100	12797B	MH035242	23	04999
MF140011	56	04997	MH000724	42	15199B	MH035606	41	15183
MF140020	104	11699C		61	07347C	MH035618	93	10199
MF140023	42	15199EB	MH000732	95	11424B	MH035619	91	10071
MF140213	56	04997B	MH000733	26	02199	MH035620	91	10077
	59	05496M	MH000829	100	12797	MH035622	91	10071B
	89	05477	MH000840	104	14199B	MH035626	53	04379F
MF240050	26	02192E	MH000843	111	48959	MH037087	42	15197F
MF241222	33	03277C	MH000922	42	15199DE		59	05398
MF241230	87	07499C	MH000924	104	14199B	MH037116	59	05491B
MF241232	87	07499C	MH000931	23	01597B	MH037126	23	01598D
MF300841	26	02192BB	MH000999	23	04956B	MH037137	19	01385H
MF300843	49	04178C		42	15199DC		19	01385M
MF300845	46	01397		104	14199C	MH037279	56	04996B

部 品 番 号 順 索 引
PARTS NUMBER INDEX

A4

部品番号 PART NO.	ページ PAGE	見出番号 REF.NO.	部品番号 PART NO.	ページ PAGE	見出番号 REF.NO.	部品番号 PART NO.	ページ PAGE	見出番号 REF.NO.
MH037397	41	15192BC	0160100540	73	07267F	0297314680	63	07117D
MH037453	41	15192E	0160101640	73	07267B	1050190700	82	07420
MH037507	41	15192D	0166502230	63	07102C	1050414130	82	07410A
MH037716	56	04996D	0200061240	63	07104D	1051107550	82	07400A
MH037723	46	01385	0200061640	71	07207D	1052071200	61	07010A
MH037725	19	01385J		71	07207KB		77	07010A
MH037762	17	01287B	0200064540	71	07207J	1052106070	61	07010A
MH037788	19	01385J	0201062040	63	07143E		77	07010A
	46	04296		71	07207	1054078050	61	07040A
MH038906	56	04987		71	07207K		71	07040A
	89	05472	0201063640	71	07207G	1054078110	61	07040A
MH038913	41	15192B	0201065040	71	07207H		71	07040A
MH039564	46	04298	0201181640	71	07207PB	1056630550	61	07020A
MH040026	26	03035	0240302030	63	07129		79	07020A
MN143845	23	04903A	0258031310	71	07235B	1056812790	61	07030A
MS146002	59	05496P		71	07235C		75	07030A
MS146003	23	01597B	0258031610	71	07235C	1066762602	61	07000A
	42	15199C	0258051910	63	07124	1310410800	63	07119
MS146004	23	04956D	0265061040	71	07227D	1314244620	67	07155C
	46	01397B	0265081240	82	07406D	1340010000	63	07108B
	46	01397D	0265101340	63	07119H	1340421400	63	07119K
	56	04997C	0265121540	71	07227K	1340430800	63	07113E
MS146005	108	14799E	0265141840	63	07119J	1340450100	63	07135B
MS146006	53	04399	0265242940	63	07119M	1340470000	63	07143C
	59	05399	0265243040	71	07227	1340630920	63	07123
	93	10198C	0290106810	63	07104B	1341104520	67	07155B
MS146008	53	04399	0290206210	71	07207BE	1341120600	66	07149B
MS146010	51	04199	0292016010	72	07243G	1341150100	63	07119C
MS146014	53	04399D	0292312030	72	07243D	1341162400	63	07122
	93	10198B	0293008320	73	07264K	1341171400	67	07151
MS146016	53	04399C	0293020140	67	07156C	1341320300	67	07156E
MS146023	42	15199B	0293110010	72	07264D	1341350200	63	07115
	61	07347C	0293110180	72	07264D	1341350400	63	07115
MS146051	26	02199	0293110190	72	07264D	1341370100	63	07141
MS146052	111	48959	0293110210	72	07264D	1341536620	63	07136A
MS146053	46	01397C	0293110520	73	07264E	1341540620	63	07136A
MS146059	26	02192F	0293110530	73	07264E	1341652220	63	07106
MS146065	26	02192	0293110540	73	07264E	1341666920	63	07106
MS146306	33	03198	0293110550	73	07264E	1342000020	67	07154A
MS146310	61	07347	0293110560	73	07264E	1342150400	66	07149C
MS146351	30	03775	0293110570	73	07264E	1342160000	63	07144B
MS146397	30	03775	0293111070	72	07264	1342170500	64	07144C
MS446183	108	14788	0293205020	73	07277F	1342220000	63	07108C
MS471107	61	07108	0293212020	73	07277C	1342410021	66	07147C
MS660170	42	15195B	0293310190	75	07361C	1342564500	63	07138
	42	15195C	0293310240	82	07406B	1343030000	64	07146CB
MS666134	17	01296F	0293316030	77	07307C	1343030100	64	07146CB
MS666135	17	01296H	0293326030	77	07307B	1343030200	64	07146CB
MS666136	17	01296EB	0293414130	63	07119F	1343030300	64	07146CB
MS666137	17	01296E		77	07307D	1343030400	64	07146CB
	19	01395M	0296020010	66	07148	1343060100	63	07102
MS666220	46	04296	0296208050	72	07245C	1343140000	64	07146C
S409S00008	104	14198	0296310030	72	07244E	1343140100	64	07146C
S930P81170	108	14205C	0296318020	72	07244B	1343140200	64	07146C
S930P90670	108	14205B	0296325070	72	07244D	1343140300	64	07146C
0066502048	100	12768	0296352020	72	07244C	1343140400	64	07146C
0105351040	72	07255F	0296355010	63	07126E	1343140500	64	07146C
0122061640	63	07143F	0297310180	63	07117C	1343140600	64	07146C
0130208040	72	07243KC	0297314570	63	07117E	1343161700	63	07113C
0130210040	63	07125C		77	07305C	1343250800	75	07367

部 品 番 号 順 索 引
PARTS NUMBER INDEX

A5

部品番号 PART NO.	ページ PAGE	見出番号 REF.NO.	部品番号 PART NO.	ページ PAGE	見出番号 REF.NO.	部品番号 PART NO.	ページ PAGE	見出番号 REF.NO.
1343712800	63	07109	1394006200	66	07146D	1505832500	83	07432C
1344960600	63	07137	1394006300	66	07146D	1505832600	83	07432C
1345630900	66	07147D	1394006400	66	07146D	1505832700	83	07432C
1392060400	63	07125B	1394006500	66	07146D	1505832800	83	07432C
1392060600	72	07243J	1394006600	66	07146D	1505832900	83	07432C
1393080900	73	07277K	1394006700	66	07146D	1505833000	83	07432C
1393081000	73	07277K	1394006800	66	07146D	1505833100	83	07432C
1394000900	64	07146D	1394081400	73	07264E	1505833200	83	07432C
1394001000	64	07146D	1394081500	73	07264E	1505833300	83	07432C
1394001100	64	07146D	1394100000	72	07264D	1505833400	83	07432C
1394001200	64	07146D	1394100100	72	07264D	1505833500	83	07432C
1394001300	64	07146D	1394103000	72	07264D	1505833600	83	07432C
1394001400	64	07146D	1394103100	72	07264D	1505833700	83	07432C
1394001500	64	07146D	1394103200	73	07264D	1505833800	84	07432C
1394001600	64	07146D	1394110000	72	07264B	1505833900	84	07432C
1394001700	64	07146D	1396110000	72	07245B	1505834000	84	07432C
1394001800	64	07146D	1396250000	63	07127	1505834100	84	07432C
1394001900	64	07146D	1396480300	75	07369	1505834200	84	07432C
1394002000	64	07146D	1397150400	63	07126D	1505834300	84	07432C
1394002100	64	07146D	1397220400	63	07126C	1505834400	84	07432C
1394002200	65	07146D	1397290400	63	07126F	1505834500	84	07432C
1394002300	65	07146D	1505251700	86	07491B	1505834600	84	07432C
1394002400	65	07146D	1505251701	86	07491B	1505834700	84	07432C
1394002500	65	07146D	1505390700	86	07433C	1505834800	84	07432C
1394002600	65	07146D	1505390800	86	07433C	1505834900	84	07432C
1394002700	65	07146D	1505390900	86	07433C	1505835000	84	07432C
1394002800	65	07146D	1505391000	86	07433C	1505835100	84	07432C
1394002900	65	07146D	1505391100	86	07433C	1505835200	84	07432C
1394003000	65	07146D	1505391200	86	07433C	1505835300	84	07432C
1394003100	65	07146D	1505391300	86	07433C	1505835400	84	07432C
1394003200	65	07146D	1505391400	86	07433C	1505835500	84	07432C
1394003300	65	07146D	1505602001	82	07416B	1505835600	84	07432C
1394003400	65	07146D	1505602100	82	07416	1505835700	84	07432C
1394003500	65	07146D	1505626500	86	07434C	1505835800	84	07432C
1394003600	65	07146D	1505626600	86	07434B	1505835900	84	07432C
1394003700	65	07146D	1505830000	82	07432C	1505836000	84	07432C
1394003800	65	07146D	1505830100	82	07432C	1505836100	84	07432C
1394003900	65	07146D	1505830200	82	07432C	1505836200	84	07432C
1394004000	65	07146D	1505830300	82	07432C	1505836300	85	07432C
1394004100	65	07146D	1505830400	82	07432C	1505836400	85	07432C
1394004200	65	07146D	1505830500	82	07432C	1505836500	85	07432C
1394004300	65	07146D	1505830600	82	07432C	1505836600	85	07432C
1394004400	65	07146D	1505830700	82	07432C	1505836700	85	07432C
1394004500	65	07146D	1505830800	82	07432C	1505836800	85	07432C
1394004600	65	07146D	1505830900	82	07432C	1505836900	85	07432C
1394004700	66	07146D	1505831000	82	07432C	1505837000	85	07432C
1394004800	66	07146D	1505831100	82	07432C	1505837100	85	07432C
1394004900	66	07146D	1505831200	82	07432C	1505837200	85	07432C
1394005000	66	07146D	1505831300	83	07432C	1505837300	85	07432C
1394005100	66	07146D	1505831400	83	07432C	1505837400	85	07432C
1394005200	66	07146D	1505831500	83	07432C	1505837500	85	07432C
1394005300	66	07146D	1505831600	83	07432C	1505837600	85	07432C
1394005400	66	07146D	1505831700	83	07432C	1505837700	85	07432C
1394005500	66	07146D	1505831800	83	07432C	1505837800	85	07432C
1394005600	66	07146D	1505831900	83	07432C	1505837900	85	07432C
1394005700	66	07146D	1505832000	83	07432C	1505838000	85	07432C
1394005800	66	07146D	1505832100	83	07432C	1505838100	85	07432C
1394005900	66	07146D	1505832200	83	07432C	1505838200	85	07432C
1394006000	66	07146D	1505832300	83	07432C	1505838300	85	07432C
1394006100	66	07146D	1505832400	83	07432C	1505838400	85	07432C

部 品 番 号 順 索 引
PARTS NUMBER INDEX

A6

部品番号 PART NO.	ページ PAGE	見出番号 REF.NO.	部品番号 PART NO.	ページ PAGE	見出番号 REF.NO.	部品番号 PART NO.	ページ PAGE	見出番号 REF.NO.
1505838500	85	07432C	1542346920	71	07239	1568091620	75	07017
1505838600	85	07432C	1542371100	72	07247	1568946100	75	07385B
1505838700	85	07432C	1542393320	71	07236D	1568957300	75	07385
1505838800	86	07432C	1543210400	71	07211D	1568986220	75	07359A
1505838900	86	07432C	1543220100	71	07213	3000424300	33	03275
1505900600	86	07433B	1543265120	71	07236B	3000715301	46	01394C
1505900700	86	07433B	1543274200	73	07269K	3004211900	15	01987D
1505900800	86	07433B	1543277300	73	07269E	3013302300	108	14782
1505900900	86	07433B	1543400120	71	07236F	3016101200	61	07051
1505901000	86	07433B	1543506000	72	07248B	3090113709	17	01208
1505901100	86	07433B	1543582500	72	07256	3090401600	33	03314
1505901200	86	07433B	1543589420	71	07209	3090402200	33	03276
1505901300	86	07433B	1543643420	71	07236K	3090702600	46	01307H
1506098100	82	07409	1543715600	71	07227B	3090702800	19	01385N
1506131700	82	07404	1543732200	72	07247E	3090702900	35	03151
1506241800	86	07486F	1543817900	71	07236K	3090703500	46	01307J
1506515400	86	07493B	1543900300	71	07227C	3090705800	46	01333
1520004620	77	07309	1545002020	71	07217A	3090722300	19	01320
1521001120	77	07315	1545003020	71	07217A	3091201400	26	02185
1521020400	77	07322C	1550032101	71	07236KB	3092020100	26	03034
1521051500	77	07316B	1550043600	72	07262F	3093602300	56	04925B
1521113221	77	07325	1550060700	71	07207P	3093613500	56	15113
1521150200	77	07326	1554023800	72	07247G	3093900300	53	04375
1521160200	77	07322B	1563140600	75	07354	3096102200	82	07403
1521170400	77	07316C	1563150200	75	07368	3096102300	82	07405
1521210200	77	07321	1563160000	75	07375	3097502060	41	15114
1522005620	77	07010	1563190200	75	07361	3097502070	41	15115
1523007120	77	07305B	1563220000	75	07387	3097504400	41	15176F
1530212220	71	07238	1566037200	79	07181B	3097506600	42	15197D
1540004700	71	07232A	1566055320	79	07184C	3097522100	40	15061
1540042822	71	07232A	1566056520	79	07184B	3097522500	40	15105
1540072900	72	07249C	1566095300	79	07020	3097522700	40	15096
1540100100	72	07255D	1566152600	79	07185B	3097522800	40	15035
1540101100	72	07255C	1566153200	79	07185D	3097522900	41	15183C
1540110100	72	07243F	1566311900	79	07020B	3097523100	40	15051
1540111100	72	07243KB	1566334700	79	07181	3097523200	40	15106
1540111700	72	07243K	1566338300	79	07181C	3097523300	41	15121
1540312400	72	07255B	1566339100	79	07181D	3097524500	40	15033
1540351600	72	07243E	1567230300	75	07353	3111204100	26	02113
1540360300	72	07249B	1567230400	75	07353B	3111204200	26	02115
1540631400	71	07217	1567280800	75	07383B	3112304100	35	03295C
1540644500	71	07217C	1567280900	75	07383B	3113902201	51	04191
1541010020	71	07226A	1567281000	75	07383B	3116101800	61	07051
1541232320	73	07265	1567281100	75	07383B	3117502109	35	03291D
1541540500	73	07269D	1567281200	75	07383C	3117503901	40	15054C
1541580820	71	07221D	1567281300	75	07383C	3120434200	33	03450
1541591200	72	07243M	1567281400	75	07383C	3120978101	20	03044
1541770720	71	07221C	1567281500	75	07383C	3120978201	20	03044
1541770920	71	07221C	1567282000	75	07383B	3120978301	20	03044
1542006920	71	07236C	1567282100	75	07383B	3120978401	20	03044
1542044300	71	07211B	1567282200	75	07383C	3121202300	26	02111
1542044400	71	07211C	1567282300	75	07383C	3121733100	30	03798
1542060200	73	07277D	1568003420	75	07364	3124050500	51	04111C
1542062000	71	07216C	1568016200	75	07358	3124050900	51	04189
1542062800	71	07216B	1568020420	75	07359	3124051203	51	04107
1542114320	71	07236A	1568060900	75	07372	3124053900	51	04144
1542171420	71	07236A	1568070900	75	07381C	3124054500	51	04191B
1542302920	72	07239	1568071100	75	07381	3124618702	93	10898B
1542314900	72	07247B	1568080500	75	07389	4913442200	100	12778
1542322420	72	07248C	1568090300	75	07384	4916814020	100	12798

部 品 番 号 順 索 引
PARTS NUMBER INDEX

A7

部品番号 PART NO.	ページ PAGE	見出番号 REF.NO.	部品番号 PART NO.	ページ PAGE	見出番号 REF.NO.	部品番号 PART NO.	ページ PAGE	見出番号 REF.NO.
4916855200	100	12571						
4917414000	100	12516						
4917421100	100	12503						
4917421110	100	12503						
4917422300	100	12769D						
4917422600	100	12796						
4917422700	100	12796C						
4917423100	100	12597						
4917423200	100	12769						
4917423300	100	12769E						
4917442200	100	12778						
4918123100	100	12597D						
4918801661	100	12500A						
4918810400	100	12545						
4918819100	100	12572						
4918821500	100	12504						
4918822210	100	12525						
4918822500	100	12546						
4918825300	100	12544A						
4918830100	100	12606						
4918830130	100	12606						
4918842100	100	12766						
4918842300	100	12593						
4918842400	100	12596						
4918845120	100	12623						
4918855120	100	12521						

Silverhorn.CO.UK

部 品 名 称 顺 索 引

PARTS NAME INDEX

Silverhorn.CO.UK

Silverhorn.CO.UK

部 品 名 称 順 索 引
P A R T S N A M E I N D E X

B1

部 品 名 称 P A R T S N A M E	ページ PAGE	見出番号 REF.NO.	部 品 名 称 P A R T S N A M E	ページ PAGE	見出番号 REF.NO.
(A)			BOLT,ENG OIL PUMP INR	49	04098
AIR COMPRESSOR ASSY	40	15000A	BOLT,ENG RR PLATE	26	02199
ALTERNATOR ASSY	108	14200A	BOLT,EXHAUST MANIFOLD	97	12099
ARMATURE KIT,STARTER	104	14001	BOLT,FLYWHEEL	27	03797
(B)			BOLT,FLYWHEEL HOUSING	26	02192
BALL,ENG OIL PUMP INR	49	04099		26	02192BB
BALL,STARTER INR	104	14198		26	02192C
BEARING & SLEEVE KIT,STARTER	104	14003		26	02192E
BEARING SET,CONNROD	29	03050		26	02192F
BEARING SET,CRANKSHAFT	20	03040	BOLT,FUEL FILTER	59	05399
BEARING,ALTERNATOR ROTOR	108	14205B	BOLT,FUEL INJECTION NOZZLE	86	07494
	108	14205C	BOLT,FUEL INJECTION TUBE	87	07499B
BEARING,FLYWHEEL DRIVE PINION	26	03035		87	07499C
BEARING,INJECTION PUMP BODY	63	07102	BOLT,FUEL LINE	59	05496M
	63	07102C		59	05496P
BEARING,STARTER ARMATURE	104	14008C	BOLT,FUEL RETURN LINE	89	05477
BEARING,T/C SHAFT	100	12503	BOLT,INJECTION PUMP	61	07347
BEARING,WATER PUMP	91	10001		61	07347C
	91	10001B	BOLT,INJECTION PUMP BODY	63	07104B
BELT,ALTERNATOR & OTHERS	91	10040		63	07104D
BLOCK ASSY,CYLINDER	7	01300A	BOLT,INJECTION PUMP COUPLING	79	07181
BLOCK,INJECTION PUMP BODY	63	07106		79	07181B
BODY ASSY,INJECTION PUMP	61	07009A		79	07181C
	63	07009A	BOLT,INJECTION PUMP GOVERNOR	71	07181D
BOLT SET,STARTER	104	14011		71	07207
BOLT,AIR COMPRESSOR	42	15199B		71	07207BE
	42	15199C		71	07207D
	42	15199D		71	07207G
	42	15199DC		71	07207H
	42	15199DE		71	07207J
	42	15199EB		71	07207K
BOLT,AIR COMPRESSOR INR	42	15198B		71	07207KB
	42	15198C		71	07207P
BOLT,ALTERNATOR	108	14799B		71	07207PB
	108	14799C	BOLT,INLET MANIFOLD,NO.1	95	11424
	108	14799D		95	11424B
	108	14799E	BOLT,INTAKE AIR HEATER	104	11699C
BOLT,CAMSHAFT	33	03198	BOLT,OIL FILTER	51	04199
BOLT,CONNROD	29	03006	BOLT,OIL STRAINER	49	04178
BOLT,COOLING WATER LINE	93	10198B		49	04178C
	93	10198C	BOLT,P/S OIL PUMP	111	48959
BOLT,CRANKSHAFT PULLEY	30	03787	BOLT,ROCKER COVER	15	01198
BOLT,CYLINDER BLOCK	20	01397N	BOLT,STARTER	104	14199B
	46	01397		104	14199C
	46	01397B		105	14199D
	46	01397C	BOLT,T/C	100	12797
	46	01397D		100	12797B
BOLT,CYLINDER HEAD	17	01298B	BOLT,T/C INR	100	12798
	17	01298C	BOLT,TIMING GEAR TRAIN	35	03298D
BOLT,ENG BREATHER	15	01978		35	03298E
BOLT,ENG OIL COOLER	53	04399	BOLT,TORSIONAL DAMPER	30	03775
	53	04399C	BOLT,VALVE GEAR TRAIN	33	03277B
	53	04399D		33	03277C
BOLT,ENG OIL FILLER	23	04956B	BOLT,WATER PUMP	91	10088
	23	04956D		91	10088D
BOLT,ENG OIL LINE	56	04997	BRACE,ALTERNATOR ADJUSTING	108	14216
	56	04997B	BRACKET ASSY,ALTERNATOR,FR	108	14224A
	56	04997C	BRACKET ASSY,ALTERNATOR,RR	108	14225A
BOLT,ENG OIL PAN	23	01597B	BRACKET,AIR COMPRESSOR HEAD		
BOLT,ENG OIL PUMP	49	04096	PIPE	40	15014

部 品 名 称 順 索 引
P A R T S N A M E I N D E X

B2

部 品 名 称 P A R T S N A M E	ページ PAGE	見出番号 REF.NO.	部 品 名 称 P A R T S N A M E	ページ PAGE	見出番号 REF.NO.
BRACKET,ALTERNATOR MOUNTING	108	14223	CLAMP,FUEL INJECTION TUBE	86	07498F
BRACKET,FUEL RETURN LINE	89	05476		87	07498G
BRACKET,INJECTION PUMP	61	07011	CLAMP,FUEL LINE	59	05494
BRACKET,INJECTION PUMP GOVERNOR	71	07209	CLAMP,FUEL RETURN LINE	89	05474
BRACKET,ROCKER SHAFT	33	03302B	CLAMP,T/C	100	12799B
BRACKET,STARTER,FR	104	14016	CLIP,AIR COMPRESSOR	41	15194B
BRACKET,STARTER,RR	104	14017		41	15194C
BREATHER,ENG	15	01303	CLIP,COOLING WATER LINE	93	10193
BRUSH,STARTER	104	14020	CLIP,ENG BREATHER	15	01987D
BUSHING,CONNROD	29	03016	CLIP,ENG OIL LINE	56	04992
BUSHING,CYLINDER BLOCK	20	01396B	CLUTCH KIT,STARTER PINION & REDUCTION	104	14024
	20	01396C	CLUTCH,STARTER OVERRUNNING	104	14025
	20	01396D	COCK,CYLINDER BLOCK WATER DRAIN	46	01306
	20	01396F	COIL,ALTERNATOR ROTOR	108	14241
	20	01396G	COLLAR,AIR COMPRESSOR	40	15023
	20	01396H	COLLAR,INJECTION PUMP GOVERNOR	71	07216B
BUSHING,INJECTION PUMP BODY	61	07108		71	07216C
	63	07108B	COLLAR,TIMING GEAR TRAIN	35	03271
	63	07108C	CONNECTING ROD ASSY	29	03010A
BUSHING,INJECTION PUMP GOVERNOR	71	07211B	CONNECTING ROD ASSY,AIR COMPRESSOR	40	15024A
BUSHING,INJECTION PUMP GOVERNOR	71	07211C	CONNECTOR,FUEL INJECTION NOZZLE	82	07409
BUSHING,INJECTION PUMP GOVERNOR	71	07211D	COUPLING ASSY,INJECTION PUMP	61	07020A
BUSHING,TIMING GEAR TRAIN	35	03107B		79	07020A
	35	03107C	COUPLING,INJECTION PUMP	79	07020B
BUSHING,VALVE GEAR TRAIN (C)	33	03276		79	07020B
CAM,INJECTION PUMP TIMER	75	07353	COUPLING,T/C HOUSING	100	12516
	75	07353B	COVER ASSY,ENG OIL PUMP	49	04007A
CAMSHAFT	33	03100	COVER ASSY,INJECTION PUMP GOVERNOR	71	07217A
CAMSHAFT,INJECTION PUMP BODY	63	07109	COVER,CYLINDER BLOCK	46	01307B
CAP ASSY,ENG OIL FILLER	23	04903A		46	01307C
CAP,CYLINDER BLOCK	19	01395J		46	01307D
	19	01395M		46	01307H
CAP,CYLINDER HEAD	17	01296E		46	01307J
	17	01296EB	COVER,ENG OIL COOLER	53	01307K
	17	01296F	COVER,FLYWHEEL HOUSING TIMING POINTER	26	02111
	17	01296H	COVER,FLYWHEEL HOUSING,RR	26	02113
CAP,INJECTION PUMP GOVERNOR	71	07213	COVER,INJECTION PUMP BODY	63	07113C
CAP,INJECTION PUMP TIMER	75	07354		63	07113E
CAP,VALVE GEAR TRAIN	33	03275	COVER,INJECTION PUMP GOVERNOR	71	07217
CASE,OIL FILTER	51	04107		71	07217C
CASE,THERMOSTAT	93	10100	COVER,INJECTION PUMP TIMER	75	07017
CASE,WATER PUMP	91	10012	COVER,P/S OIL PUMP	111	48024
CENTER BOLT,OIL FILTER	51	04111B	COVER,ROCKER	15	01100
	51	04111C	COVER,T/C COMPRESSOR	100	12521
CHECK VALVE,CYLINDER BLOCK PISTON LUBRIC	19	01305	COVER,THERMOSTAT CASE	93	10106
CLAMP,AIR COMPRESSOR	42	15195B	COVER,WATER PUMP	91	10013
	42	15195C	CRANKCASE ASSY,AIR COMPRESSOR	40	15026A
CLAMP,CYLINDER BLOCK	46	01394B	CRANKSHAFT ASSY	11	03000A
	46	01394C	CRANKSHAFT,AIR COMPRESSOR (D)	40	15031
CLAMP,ENG BREATHER	15	01988	DAMPER,CRANKSHAFT TORSIONAL	29	03022
CLAMP,ENG OIL FILLER	23	04993	DAMPER,INJECTION PUMP GOVERNOR	71	07221C
CLAMP,ENG OIL LINE	56	04994		71	07221D
	56	04994B	DEFLECTOR,INJECTION PUMP BODY	63	07115

部 品 名 称 順 索 引
P A R T S N A M E I N D E X

B3

部 品 名 称 P A R T S N A M E	ページ PAGE	見出番号 REF.NO.	部 品 名 称 P A R T S N A M E	ページ PAGE	見出番号 REF.NO.
DEFLECTOR,T/C OIL	100	12525		20	01399M
DIRECTOR,CYLINDER HEAD WATER	17	01207B		20	01399N
DUST SEAL,FUEL INJECTION NOZZLE HOLDER	82	07403		46	01399
(E)				46	01399B
ELEMENT KIT,BY-PASS OIL FILTER	51	04130		46	01399C
ELEMENT KIT,MAIN & BY-PASS OIL FILTER	51	04180	GASKET,CYLINDER BLOCK SIDE COVER	46	01399E
ELEMENT KIT,OIL FILTER	51	04140	GASKET,CYLINDER HEAD	46	01326
ELEMENT,ENG OIL COOLER	53	04322	GASKET,ENG OIL COOLER COVER	17	01210
ENGINE ASSY,SHORT	3	01010A	GASKET,ENG OIL FILLER	53	04334
ENGINE HANGER	46	02200B	GASKET,ENG OIL LINE	23	04991B
EYEBOLT,AIR COMPRESSOR	42	15197B	GASKET,ENG OIL LINE	56	04998B
	42	15197D		56	04998C
	42	15197E	GASKET,ENG OIL PAN	23	01510
	42	15197F	GASKET,ENG OIL PAN DRAIN PLUG	23	01521
EYEBOLT,ENG OIL LINE	56	04996B	GASKET,ENG RR PLATE	26	02114
	56	04996D	GASKET,EXHAUST MANIFOLD	97	12010
EYEBOLT,FUEL FILTER	59	05398	GASKET,FLYWHEEL HOUSING	26	02116
EYEBOLT,FUEL INJECTION NOZZLE	82	07404	GASKET,FLYWHEEL HOUSING RR COVER	26	02115
EYEBOLT,INJECTION PUMP BODY	63	07117C	GASKET,FUEL FILTER	59	05394E
	63	07117D		59	05394F
	63	07117E	GASKET,FUEL INJECTION NOZZLE	82	07405
EYEBOLT,INJECTION PUMP FUEL FEED PUMP	77	07305B	GASKET,FUEL INJECTION NOZZLE INR	82	07406B
EYEBOLT,INJECTION PUMP FUEL FEED PUMP	77	07305C	GASKET,FUEL INJECTION NOZZLE INR	82	07406D
(F)			GASKET,INJECTION PUMP BODY	63	07119
FILLER,ENG OIL	23	04905		63	07119C
FLANGE,INJECTION PUMP TIMER	75	07358		63	07119F
FLANGE,WATER PUMP PULLEY DRIVE	91	10016		63	07119H
FLYWEIGHT ASSY,INJECTION PUMP GOVERNOR	71	07226A	GASKET,INJECTION PUMP FUEL FEED PUMP	63	07119J
FLYWEIGHT ASSY,INJECTION PUMP TIMER	75	07359A	GASKET,INJECTION PUMP FUEL FEED PUMP	63	07119K
FLYWEIGHT,INJECTION PUMP TIMER	75	07359	GASKET,INJECTION PUMP FUEL FEED PUMP	63	07119M
FLYWHEEL ASSY	26	03030A	GASKET,INJECTION PUMP FUEL FEED PUMP	77	07307B
FUEL FILTER	59	05300	GASKET,INJECTION PUMP GOVERNOR	77	07307D
FUEL FILTER ASSY	59	05300A		71	07227
(G)				71	07227B
GASKET KIT,ENG OVERHAUL	13	01070		71	07227C
GASKET SET,STARTER YOKE	104	14068		71	07227D
GASKET,AIR COMPRESSOR	41	15189B	GASKET,INJECTION PUMP TIMER	71	07227K
	41	15189C		75	07361
	41	15189D		75	07361C
	41	15189E	GASKET,INLET MANIFOLD	95	11410
	41	15189F	GASKET,INLET MANIFOLD COVER	95	11414
GASKET,AIR COMPRESSOR CYLINDER HEAD	40	15033	GASKET,INTAKE AIR HEATER	104	11615
GASKET,AIR COMPRESSOR CYLINDER LINER	40	15034	GASKET,OIL FILTER	51	04192
GASKET,AIR COMPRESSOR DELIVERY VALVE	40	15035	GASKET,OIL FILTER CASE	51	04115
GASKET,AIR COMPRESSOR SUCTION VALVE	40	15037	GASKET,OIL FILTER INR	51	04184B
GASKET,COOLING WATER LINE	93	10191	GASKET,OIL STRAINER	49	04161B
	93	10191B		49	04161C
GASKET,CRANKSHAFT FR OIL SEAL CASE	46	02023	GASKET,STARTER INR	49	04161D
GASKET,CYLINDER BLOCK	20	01399K	GASKET,STARTER INR	104	14034B
			GASKET,T/C	100	12784
				100	12784B
			GASKET,T/C OIL RETURN PIPE TO CYLINDER B	56	12548
			GASKET,T/C OIL RETURN TUBE	56	12537

部 品 名 称 順 索 引
P A R T S N A M E I N D E X

B4

部 品 名 称 P A R T S N A M E	ページ PAGE	見出番号 REF.NO.	部 品 名 称 P A R T S N A M E	ページ PAGE	見出番号 REF.NO.
GASKET,THERMOSTAT COVER	93	10122		41	15192BC
GASKET,WATER PUMP	91	10021		41	15192D
GAUGE,ENG OIL LEVEL	23	04911		41	15192E
GEAR & CASE KIT,ENG OIL PUMP	49	04005	JOINT,AIR COMPRESSOR INR	41	15191
GEAR ASSY,CAM IDLER	35	03132A	JOINT,ENG OIL LINE	56	04987
GEAR ASSY,INJECTION PUMP IDLER	35	03135A	JOINT,ENG OIL PRESSURE GAUGE	46	04298
GEAR,CAMSHAFT	35	03136	JOINT,FUEL LINE	59	05491B
GEAR,CRANKSHAFT	35	03026	JOINT,FUEL RETURN LINE	89	05472
GEAR,ENG OIL PUMP DRIVEN	49	04016	(K)		
GEAR,ENG OIL PUMP IDLER	49	04017	KEY,AIR COMPRESSOR	41	15186
GEAR,INJECTION PUMP DRIVE	35	03118	KEY,CAMSHAFT	33	03196
GEAR,STARTER REDUCTION	104	14037	KEY,INJECTION PUMP BODY	63	07124
GEAR,STARTER REDUCTION INTERNAL	104	14038	KEY,INJECTION PUMP GOVERNOR	71	07235B
GEAR,STARTER REDUCTION PINION	104	14039		71	07235C
GOVERNOR ASSY,INJECTION PUMP	61	07040A	KEY,TIMING GEAR TRAIN	35	03297
	71	07040A	(L)		
GROMMET,STARTER INR	104	14178	LEVER ASSY,INJECTION PUMP		
GUIDE,ENG OIL LEVEL GAUGE	23	04912	GOVERNOR	71	07236A
GUIDE,EXHAUST VALVE	17	03470	LEVER KIT,STARTER PINION SHIFT	104	14046
GUIDE,INLET VALVE	17	03460	LEVER,INJECTION PUMP GOVERNOR	71	07236B
(H)				71	07236C
HEAD ASSY,AIR COMPRESSOR				71	07236D
CYLINDER	40	15043A		71	07236F
HEAD ASSY,ENG CYLINDER	5	01200A		71	07236K
HEAD,FUEL FILTER	59	05314		71	07236KB
HEATER,INTAKE AIR	104	11610	LIMITER,INJECTION PUMP GOVERNOR	71	07238
HOLDER ASSY,AIR COMPRESSOR			LINER & PISTON KIT	9	01340
BEARING	40	15045A	LINER,AIR COMPRESSOR CYLINDER	40	15061
HOLDER ASSY,FUEL INJECTION			LINER,CYLINDER	19	01342
NOZZLE	82	07410A	LINK,INJECTION PUMP GOVERNOR	71	07239
HOLDER ASSY,STARTER BRUSH	104	14044A	LOCK,VALVE SPRING RETAINER	33	03450
HOLDER,AIR COMPRESSOR DELIVERY			(M)		
VALVE	40	15047	MANIFOLD,EXHAUST	97	12000
HOLDER,AIR COMPRESSOR SUCTION			MANIFOLD,EXHAUST,CTR	97	12046
VALVE	40	15051	MANIFOLD,INLET,FR	95	11431
HOLDER,INJECTION PUMP BODY	63	07122	MANIFOLD,INLET,RR	95	11432
HOSE,AIR COMPRESSOR SUCTION	40	15054B	(N)		
	40	15054C	NAME PLATE,ENG	113	01911C
HOSE,CYLINDER BLOCK WATER			NAME PLATE,T/C	100	12571
DRAIN	46	01333	NOZZLE & HOLDER ASSY,FUEL		
HOSE,ENG BREATHER	15	01951	INJECTION	82	07400A
HOSE,T/C	100	12781	NOZZLE,FUEL INJECTION	82	07420
HOSE,T/C OIL RETURN TUBE	56	12543	NUT KIT,ALTERNATOR PULLEY	108	14266
HOSE,THERMOSTAT WATER BY-PASS	93	10134	NUT,AIR COMPRESSOR INR	41	15184C
HOUSING ASSY,INJECTION PUMP				41	15184D
GOVERNOR	71	07232A	NUT,ALTERNATOR	108	14788
HOUSING ASSY,T/C BEARING	100	12544A		108	14788B
HOUSING,FLYWHEEL	26	02100	NUT,ALTERNATOR INR	108	14787B
HOUSING,INJECTION PUMP BODY	63	07123	NUT,CONNROD	29	03031
HOUSING,INJECTION PUMP FUEL			NUT,COOLING WATER LINE	93	10187
FEED PUMP	77	07309	NUT,ENG OIL COOLER INR	53	04377
HOUSING,INJECTION PUMP TIMER	75	07364	NUT,ENG OIL LINE	56	04979
HOUSING,T/C TURBINE	100	12545	NUT,ENG OIL PUMP INR	49	04079
(I)			NUT,EXHAUST MANIFOLD	97	12096
IMPELLER,WATER PUMP	91	10025	NUT,FLYWHEEL HOUSING	26	02188
INSERT,T/C BEARING HOUSING	100	12546	NUT,FUEL INJECTION NOZZLE	86	07493B
INSULATOR,EXHAUST MANIFOLD			NUT,FUEL INJECTION TUBE	86	07497B
HEAT	97	12043	NUT,INJECTION PUMP BODY	63	07125B
(J)				63	07125C
JOINT,AIR COMPRESSOR	41	15192B	NUT,INJECTION PUMP GOVERNOR	72	07243D

部 品 名 称 順 索 引
P A R T S N A M E I N D E X

B5

部 品 名 称 P A R T S N A M E	ページ PAGE	見出番号 REF.NO.	部 品 名 称 P A R T S N A M E	ページ PAGE	見出番号 REF.NO.
	72	07243E	OIL PAN,ENG	23	01500
	72	07243F	OIL PUMP ASSY,ENG	49	04000A
	72	07243G	OIL SEAL,AIR COMPRESSOR		
	72	07243J	CRANKSHAFT,FR	40	15073
	72	07243K	OIL SEAL,CRANKSHAFT,RR	27	03080
	72	07243KB	OIL SEAL,CYLINDER BLOCK FR COVER	46	01361
	72	07243KC	OIL SEAL,INJECTION PUMP BODY	63	07127
	72	07243M	OIL SEAL,INJECTION PUMP		
NUT,INJECTION PUMP TIMER	75	07367	GOVERNOR	72	07245B
NUT,INTAKE SILENCER	104	11682	OIL SEAL,INJECTION PUMP		
NUT,STARTER	104	14195	GOVERNOR	72	07245C
	104	14195B	OIL SEAL,INJECTION PUMP TIMER	75	07369
NUT,T/C	100	12779B	OIL SEAL,WATER PUMP SHAFT	91	10049
NUT,T/C INR	100	12778		91	10049B
NUT,TIMING GEAR TRAIN	35	03296B	OIL SLINGER,CRANKSHAFT,FR	46	03033
	35	03296D	OIL SLINGER,CRANKSHAFT,RR	26	03034
NUT,VALVE GEAR TRAIN	33	03299	(P)		
NUT,WATER PUMP	91	10084	PIN,AIR COMPRESSOR PISTON	40	15074
(O)			PIN,CRANKSHAFT	30	03788
O-RING,AIR COMPRESSOR	41	15183		30	03788B
	41	15183C	PIN,CYLINDER BLOCK	19	01387H
	41	15183F		19	01387HC
O-RING,COOLING WATER LINE	93	10199		19	01387J
O-RING,CYLINDER BLOCK	19	01388		19	01387K
	19	01388B		19	01387M
O-RING,CYLINDER HEAD	17	01291		19	01387N
O-RING,ENG BREATHER	15	01983	PIN,ENG OIL PUMP INR	49	04078
O-RING,ENG OIL COOLER	53	04375	PIN,FLYWHEEL	27	03796
O-RING,ENG OIL COOLER INR	53	04379	PIN,FUEL INJECTION NOZZLE	86	07491B
	53	04379C	PIN,INJECTION PUMP BODY	63	07129
	53	04379E	PIN,INJECTION PUMP GOVERNOR	72	07247
	53	04379F		72	07247B
O-RING,ENG OIL FILLER	23	04999		72	07247E
O-RING,ENG OIL LINE	56	04978		72	07247G
O-RING,INJECTION PUMP BODY	63	07126C	PIN,INJECTION PUMP TIMER	75	07372
	63	07126D	PIN,PISTON	29	03036
	63	07126E	PIN,TIMING GEAR TRAIN	35	03294
	63	07126F	PINION KIT,STARTER	104	14054
O-RING,INJECTION PUMP GOVERNOR	72	07244B	PIPE,AIR COMPRESSOR SUCTION	40	15078
	72	07244C		40	15078B
	72	07244D	PIPE,AIR COMPRESSOR WATER INLET	40	15081
	72	07244E	PIPE,AIR COMPRESSOR WATER		
O-RING,INJECTION PUMP TIMER	75	07368	OUTLET	40	15076
O-RING,OIL FILTER	51	04191	PIPE,COOLING WATER OUTLET	93	10151
	51	04191B	PIPE,T/C TO INLET MANIFOLD	100	12563
O-RING,OIL FILTER INR	51	04182	PISTON	29	03037
O-RING,P/S OIL PUMP	111	48945	PISTON,AIR COMPRESSOR CYLINDER	40	15082
O-RING,ROCKER COVER	15	01127	PISTON,INJECTION PUMP FUEL FEED		
O-RING,T/C INR	100	12796	PUMP	77	07315
	100	12796C	PLATE,ALTERNATOR RR BRACKET	108	14286
O-RING,TIMING GEAR TRAIN	35	03295B	PLATE,CAM IDLER GEAR THRUST	35	03145
	35	03295C	PLATE,CAMSHAFT THRUST	33	03146
O-RING,VALVE GEAR TRAIN	33	03279	PLATE,CRANKSHAFT THRUST	20	03044
O-RING,WATER PUMP	91	10071	PLATE,CYLINDER BLOCK,RR	26	02122
	91	10071B	PLATE,INJECTION PUMP COUPLING	79	07184B
	91	10071C		79	07184C
O-RING,WATER PUMP INR	91	10077	PLATE,INJECTION PUMP DRIVE GEAR	35	03129
OIL COOLER ASSY,ENG	53	04300A	PLATE,INJECTION PUMP GOVERNOR	72	07248B
OIL FILTER & HEAD ASSY	51	04100A		72	07248C
OIL JET,CYLINDER BLOCK	19	01381	PLATE,INTAKE AIR HEATER CABLE		

部 品 名 称 順 索 引
P A R T S N A M E I N D E X

B6

部 品 名 称 P A R T S N A M E	ページ PAGE	見出番号 REF.NO.	部 品 名 称 P A R T S N A M E	ページ PAGE	見出番号 REF.NO.
EARTH	104	11631	RING SET,PISTON	29	03060
PLATE,ROCKER SHAFT THRUST	33	03314	RING,CRANKSHAFT RR OIL SLINGER	27	03083
PLATE,T/C TURBINE BACK	100	12572	RING,INJECTION PUMP BODY	63	07141
PLUG,AIR COMPRESSOR INR	41	15179	RING,T/C SHAFT BEARING THRUST	100	12593
PLUG,COOLING WATER LINE	93	10185	RING,T/C SHAFT THRUST	100	12596
PLUG,CYLINDER BLOCK	19	01385H	RING,T/C SHAFT TURBINE PISTON	100	12597
	19	01385J		100	12597D
	19	01385K	RIVET,T/C INR	100	12768
	19	01385M	ROCKER ARM,INLET & EXHAUST		
	19	01385N	VALVE	33	03323
	46	01385	ROTOR KIT,ALTERNATOR	108	14304
PLUG,CYLINDER HEAD	17	01287B	(S)		
PLUG,ENG OIL COOLER	53	04338	SCREW,ALTERNATOR INR	108	14784B
PLUG,ENG OIL COOLER INR	53	04385		108	14784C
PLUG,ENG OIL PAN	23	01598D		108	14784D
PLUG,ENG OIL PRESSURE GAUGE	46	04296		108	14784E
PLUG,FLYWHEEL HOUSING	26	02185	SCREW,INJECTION PUMP BODY	63	07143C
	26	02185D		63	07143E
PLUG,FUEL FILTER	59	05392		63	07143F
PLUG,INJECTION PUMP BODY	63	07135B	SCREW,INJECTION PUMP GOVERNOR	72	07255B
PLUG,INJECTION PUMP FUEL FEED				72	07255C
PUMP	77	07316B		72	07255D
PLUG,INJECTION PUMP FUEL FEED				72	07255E
PUMP	77	07316C	SCREW,STARTER INR	104	14185B
PLUG,INJECTION PUMP GOVERNOR	72	07249B	SCREW,VALVE GEAR TRAIN	33	03266B
	72	07249C	SEAL RING,EXHAUST MANIFOLD	97	12092
	75	07375		97	12092B
PLUG,INJECTION PUMP TIMER	95	11475	SEAL RING,INJECTION PUMP		
PLUG,INLET MANIFOLD	51	04189	GOVERNOR	72	07256
PLUG,OIL FILTER	100	12731	SEAL UNIT,WATER PUMP SHAFT	91	10043
PLUG,T/C	35	03151	SEAL,CYLINDER LINER	19	01320
PLUG,TIMING GEAR TRAIN	91	10086	SEAL,ROCKER COVER BOLT	15	01134
PLUG,WATER PUMP	93	10898B	SEAL,VALVE STEM	33	03440
PLUG,WATER TEMPERATURE GAUGE	63	07136A	SEAT,AIR COMPRESSOR DELIVERY	40	15096
PLUNGER ASSY,INJECTION PUMP			VALVE		
BODY	26	02124	SEAT,AIR COMPRESSOR SUCTION	40	15097
POINTER,FLYWHEEL HOUSING ENG	63	07137	VALVE	49	04033
TIMING	108	14292	SEAT,ENG OIL PUMP RELIEF VALVE	17	03407
POINTER,INJECTION PUMP BODY	29	03047	SEAT,EXHAUST VALVE		
PULLEY & FAN KIT,ALTERNATOR	91	10041	SEAT,FUEL INJECTION NOZZLE	82	07416
PULLEY,CRANKSHAFT	61	07000A	HOLDER		
PULLEY,WATER PUMP	61	07010A	SEAT,FUEL INJECTION NOZZLE	82	07416B
PUMP ASSY,FUEL INJECTION	77	07010	HOLDER	63	07144B
PUMP ASSY,INJECTION PUMP FUEL			SEAT,INJECTION PUMP BODY	64	07144C
FEED	77	07010A		75	07381
PUMP ASSY,INJECTION PUMP FUEL	77	07010	SEAT,INJECTION PUMP TIMER	75	07381C
FEED				17	03411
PUMP,INJECTION PUMP FUEL FEED	82	07432C	SEAT,INLET VALVE	33	03412
PUSH ROD,FUEL INJECTION NOZZLE	33	03316	SEAT,VALVE SPRING	100	12606
HOLDER			SHAFT & TURBINE,T/C	35	03155B
PUSH ROD,ROCKER ARM	63	07138	SHAFT,CAM IDLER GEAR	35	03155C
(R)	108	14296B		49	04035
RACK,INJECTION PUMP BODY	108	14297	SHAFT,ENG OIL PUMP IDLER GEAR	72	07262F
RECTIFIER,ALTERNATOR	104	14057B	SHAFT,INJECTION PUMP GOVERNOR	91	10044
REGULATOR,ALTERNATOR	51	04127B	SHAFT,WATER PUMP	86	07433B
RELAY,STARTER SAFETY CONTROL	51	04127C	SHIM,FUEL INJECTION NOZZLE	86	07433C
RETAINER,OIL FILTER ELEMENT	33	03405		64	07146C
	26	03057	SHIM,INJECTION PUMP BODY	64	07146CB
RETAINER,VALVE SPRING	40	15087		64	07146D
RING GEAR,FLYWHEEL					
RING SET,AIR COMPRESSOR PISTON					

部 品 名 称 順 索 引
P A R T S N A M E I N D E X

B7

部 品 名 称 P A R T S N A M E	ページ PAGE	見出番号 REF.NO.	部 品 名 称 P A R T S N A M E	ページ PAGE	見出番号 REF.NO.
SHIM,INJECTION PUMP BRACKET	61	07051	SPRING,VALVE,INR	33	03416
SHIM,INJECTION PUMP GOVERNOR	72	07264	SPRING,VALVE,OTR	33	03417
	72	07264B	STARTER ASSY	104	14000A
	72	07264D	STATOR,ALTERNATOR	108	14335
	73	07264E	STAY,AIR COMPRESSOR	41	15176F
	73	07264K	STAY,ENG OIL FILLER	23	04985
SHIM,INJECTION PUMP TIMER	75	07383B	STAY,ENG OIL LINE	56	04973C
	75	07383C	STAY,FUEL INJECTION TUBE	86	07495
SLEEVE,AIR COMPRESSOR				86	07495H
CRANKSHAFT	40	15095	STAY,FUEL LINE	59	05482
SLEEVE,INJECTION PUMP BODY	66	07147C	STAY,FUEL RETURN LINE	89	05467
	66	07147D	STOPPER KIT,STARTER PINION	104	14077
SLEEVE,INJECTION PUMP GOVERNOR	73	07265	STOPPER,INJECTION PUMP BODY	67	07151
SLEEVE,T/C INR	100	12766	STRAINER,ENG OIL PAN	49	04124
SNAP RING,AIR COMPRESSOR INR	40	15098C	STUD,AIR COMPRESSOR	41	15174B
SNAP RING,FLYWHEEL	27	03795	STUD,COOLING WATER LINE	93	10183
SNAP RING,INJECTION PUMP BODY	66	07148	STUD,CYLINDER BLOCK	19	01383
SNAP RING,INJECTION PUMP FUEL FEED PUMP	77	07321	STUD,CYLINDER HEAD	17	01282B
SNAP RING,INJECTION PUMP GOVERNOR	73	07267B	STUD,ENG OIL LINE	56	04972
SNAP RING,INJECTION PUMP GOVERNOR	73	07267F	STUD,EXHAUST MANIFOLD	97	12089
SNAP RING,INJECTION PUMP TIMER	75	07384	STUD,STARTER	104	14192
SNAP RING,PISTON	30	03798	SWITCH KIT,STARTER MAGNETIC	104	14082B
SNAP RING,T/C INR	100	12769	SWITCH,OIL FILTER BY-PASS (T)	51	04101
	100	12769D	TAPPET ASSY,INJECTION PUMP BODY	67	07154A
	100	12769E	TAPPET,INJECTION PUMP FUEL FEED PUMP	77	07325
SNAP RING,WATER PUMP INR	91	10098	TAPPET,VALVE	33	03172
	91	10098B	THERMOSTAT KIT	93	10110
SPACER,ALTERNATOR	108	14782	THRUST BEARING,T/C	100	12504
SPACER,FUEL INJECTION NOZZLE	86	07486F	TIMER ASSY,INJECTION PUMP	61	07030A
SPACER,INJECTION PUMP TIMER	75	07389		75	07030A
SPACER,WATER PUMP INR	91	10096B	TUBE,AIR COMPRESSOR OIL FEED	56	15113
SPRING PIN,CYLINDER BLOCK	19	01386M	TUBE,CYLINDER HEAD NOZZLE HOLDER	17	01208
SPRING PIN,CYLINDER HEAD	17	01288	TUBE,ENG OIL LINE	56	04925B
SPRING PIN,TIMING GEAR TRAIN	35	03293B	TUBE,ENG OIL LINE	56	04925C
SPRING,AIR COMPRESSOR DELIVERY VALVE	40	15105	TUBE,ENG OIL PUMP OUTLET	49	04045
SPRING,AIR COMPRESSOR SUCTION VALVE	40	15106	TUBE,FUEL INJECTION	82	07429
SPRING,ENG OIL COOLER BY-PASS VALVE	53	04346	TUBE,FUEL INJECTION NOZZLE FUEL RETURN	89	07512
SPRING,ENG OIL PUMP RELIEF VALVE	49	04042	TUBE,FUEL INJECTION NOZZLE FUEL RETURN	89	07512B
SPRING,FUEL INJECTION NOZZLE HOLDER	86	07434B	TUBE,FUEL LINE	59	05480M
SPRING,FUEL INJECTION NOZZLE HOLDER	86	07434C		59	05480N
SPRING,INJECTION PUMP BODY	66	07149B	TUBE,INJECTION PUMP FUEL OVERFLOW	89	07507
	66	07149C	TUBE,T/C OIL FEED	56	12617
SPRING,INJECTION PUMP FUEL FEED PUMP	77	07322B	TUBE,T/C OIL RETURN	56	12621
SPRING,INJECTION PUMP FUEL FEED PUMP	77	07322C		56	12621B
SPRING,INJECTION PUMP GOVERNOR	73	07269D	TURBOCHARGER ASSY (V)	100	12500A
	73	07269E	VALVE KIT,AIR COMPRESSOR DELIVERY	41	15114
	73	07269K	VALVE KIT,AIR COMPRESSOR SUCTION	41	15115
SPRING,INJECTION PUMP TIMER	75	07385	VALVE KIT,AIR COMPRESSOR UNLOADER	41	15116
	75	07385B	VALVE,AIR COMPRESSOR DELIVERY	41	15117
SPRING,STARTER BRUSH	104	14076	VALVE,AIR COMPRESSOR SUCTION	41	15121

部 品 名 称 順 索 引
P A R T S N A M E I N D E X

B8

部 品 名 称 P A R T S N A M E	ページ PAGE	見出番号 REF.NO.	部 品 名 称 P A R T S N A M E	ページ PAGE	見出番号 REF.NO.
VALVE,ENG OIL COOLER BY-PASS	53	04353			
VALVE,ENG OIL PRESSURE REGULATING	56	04232			
VALVE,EXHAUST	33	03420			
VALVE,INJECTION PUMP BODY	67	07155B			
	67	07155C			
VALVE,INJECTION PUMP FUEL FEED PUMP	77	07326			
VALVE,INLET (W)	33	03410			
WASHER SET,STARTER GEAR SHAFT	104	14084			
WASHER,AIR COMPRESSOR INR	41	15172B			
	41	15172C			
	41	15172D			
WASHER,FLYWHEEL HOUSING	26	02178			
	26	02178C			
WASHER,INJECTION PUMP BODY	67	07156C			
	67	07156E			
WASHER,INJECTION PUMP COUPLING	79	07185B			
	79	07185D			
WASHER,INJECTION PUMP GOVERNOR	73	07277C			
	73	07277D			
	73	07277F			
	73	07277K			
	73	07277M			
WASHER,INJECTION PUMP TIMER	75	07387			
WASHER,OIL FILTER	51	04144			
WASHER,ROCKER COVER	15	01182			
WASHER,TIMING GEAR TRAIN	35	03291D			
WATER PUMP ASSY	91	10000A			
WATER PUMP KIT	91	10010			
WHEEL,T/C COMPRESSOR (Y)	100	12623			
YOKE,STARTER	104	14086			

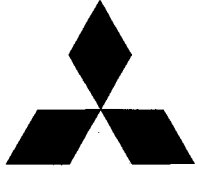

UK



Silverho